ABB INDUSTRIAL DRIVES

ACS320 drives (0.5 to 30 hp)

User's manual



List of related manuals

Drive firmware manuals and guides	Code (English)
ACS320 drives (0.5 to 30 hp) user's manual	3AUA0000062599
ACS320 Short Form User's Manual	3AUA0000086933
Guide for capacitor reforming in ACS50, ACS55, ACS150, ACS310, ACS350, ACS355, ACS550, ACH550 and R1-R4 OINT-/SINT-boards	3AFE68735190

Option manuals and guides

MFDT-01 FlashDrop user's manual	3AFE68591074
MREL-01 output relay module user's manual	3AUA0000035974
MUL1-R1 installation instructions for ACS150, ACS310, ACS320, ACS350 and ACS355	3AFE68642868
MUL1-R3 installation instructions for ACS310, ACS320, ACS350 and ACS355	3AFE68643147
MUL1-R4 installation instructions for ACS310, ACS320, ACS350 and ACS355	3AUA0000025916
SREA-01 Ethernet adapter module quick start-up guide	3AUA0000042902
SREA-01 Ethernet adapter module user's manual	3AUA0000042896

You can find manuals and other product documents in PDF format on the Internet. See section Document library on the Internet on the inside of the back cover. For manuals not available in the Document library, contact your local ABB representative.

User's manual

ACS320 drives (0.5 to 30 hp)







Table of contents	
1. Safety	
4. Mechanical installation	
6. Electrical installation	
8. Start-up	
Index	

Table of contents

.....	2
1. Safety	
Contents of this chapter	15
Use of warning symbols	15
Safety in installation and maintenance	16
Electrical safety	16
General safety	17
Safe start-up and operation	17
General safety	17
2. Introduction to the manual	
Contents of this chapter	19
Applicability	19
Target audience	19
Purpose of the manual	19
Contents of this manual	20
Related documents	21
Categorization by frame size	21
Quick installation and commissioning flowchart	22
3. Operation principle and hardware description	
Contents of this chapter	23
Operation principle	23
Product overview	24
Layout	24
Power connections and control interfaces	25
Type designation label	26
Type designation key	27
4. Mechanical installation	
Contents of this chapter	29
Checking the installation site	29
Requirements for the installation site	29
Required tools	30
Unpacking	31
Checking the delivery	31
Installing	32
Install the drive	32
Fasten clamping plates	34
5. Planning the electrical installation	
Contents of this chapter	35



6 Table of contents

Implementing the AC power line connection	35
Selecting the supply disconnecting device (disconnecting means)	36
European union	36
North America	36
Other regions	36
Checking the compatibility of the motor and drive	36
Selecting the power cables	37
General rules	37
Recommended power cable types	38
Motor cable shield	39
Additional North American requirements	39
Selecting the control cables	41
General rules	41
Relay cable	41
Control panel cable	41
Routing the cables	42
Control cable ducts	42
Protecting the drive, input power cable, motor and motor cable in short circuit situations and against thermal overload	43
Protecting the drive and input power cable in short-circuit situations	43
Protecting the motor and motor cable in short-circuit situations	43
Protecting the motor against thermal overload	43
Using residual current devices (RCD) with the drive	44
Implementing a bypass connection	44
Protecting the contacts of relay outputs	45

6. Electrical installation

Contents of this chapter	47
Checking the insulation of the assembly	47
Drive	47
Input power cable	47
Motor and motor cable	48
Checking the compatibility with IT (ungrounded) and corner grounded TN systems	49
Connecting the power cables	50
Connection diagram	50
Connection procedure	51
Connecting the control cables	52
I/O terminals	52
Default I/O connection diagram	55
Connection procedure	56
Connecting the embedded fieldbus	57
Connection diagram	57

7. Installation checklist

Contents of this chapter	59
Checking the installation	59



8. Start-up

Contents of this chapter	61
HVAC control panel features	61
General display features	62
Start-up	64
Start-up by using the Start-up assistant	64
Start-up by changing the parameters individually	65
Modes	66
Standard display mode	66
Parameters mode	68
Start-up assistant mode	70
Changed parameters mode	72
Fault logger mode	72
Drive parameter backup mode	72
Clock set mode	77
I/O settings mode	80

9. Application macros

Contents of this chapter	81
Overview of macros	81
General considerations	82
Selecting an application macro	83
Restoring defaults	83
Control wiring	83
Application / Macro listing	84
HVAC default	85
Supply fan	86
Return fan	87
Cooling tower fan	88
Condenser	89
Booster pump	90
PFA control macro	91
Internal timer	92
Internal timer with constant speeds / PRV	93
Floating point	94
Dual setpoint with PID	95
Dual setpoint with PID and constant speeds	96
E-BYPASS	97
Hand control	98
E-Clipse	99
Modbus configuration macro	100



10. Program features

Contents of this chapter	101
Start-up assistant	101
Introduction	101
List of the tasks and the relevant drive parameters	102
Contents of the assistant displays	103

8 Table of contents

Local control vs. external control	104
Local control	104
External control	105
Settings	105
Diagnostics	105
Block diagram: Start, stop, direction source for EXT1	106
Block diagram: Reference source for EXT1	106
Reference types and processing	107
Settings	107
Diagnostics	107
Reference trimming	108
Settings	108
Programmable analog inputs	109
Settings	109
Diagnostics	109
Programmable analog output	110
Settings	110
Diagnostics	110
Programmable digital inputs	111
Settings	111
Diagnostics	112
Programmable relay output	112
Settings	112
Diagnostics	112
Frequency input	113
Settings	113
Diagnostics	113
Transistor output	113
Settings	113
Diagnostics	113
Actual signals	114
Settings	114
Diagnostics	114
Power loss ride-through	115
Settings	115
DC magnetizing	115
Settings	115
Maintenance trigger	116
Settings	116
Acceleration and deceleration ramps	116
Settings	116
Critical speeds	117
Settings	117
Constant speeds	117
Settings	117
Custom U/f ratio	118
Settings	118
Diagnostics	118
R compensation	119
Settings	119
Programmable protection functions	119



AI<Min	119
Panel loss	119
External fault	119
Stall protection	119
Motor thermal protection	120
Earth fault protection	120
Incorrect wiring	121
Preprogrammed faults	121
Overcurrent	121
DC overvoltage	121
DC undervoltage	121
Drive temperature	121
Short circuit	121
Internal fault	121
Supply phase loss	121
Operation limits	121
Settings	121
Power limit	122
Automatic resets	122
Settings	122
Diagnostics	122
Supervisions	122
Settings	122
Diagnostics	122
Parameter lock	123
Settings	123
PID control	123
Process controller PID1	123
External/Trim controller PID2	123
Block diagrams	124
Settings	126
Diagnostics	126
Sleep function for the process PID (PID1) control	127
Example	128
Settings	129
Diagnostics	129
Motor temperature measurement through the standard I/O	129
Settings	131
Diagnostics	131
Timed functions	132
Examples	133
Settings	133
User load curve	134
Settings	134
Diagnostics	135
Energy optimizer	135
Settings	135
Energy saving	136
Settings	136
Diagnostics	136
Pump cleaning	137



Settings	137
Load analyzer	138
Peak value logger	138
Amplitude loggers	138
Settings	139
Diagnostics	139
PFA control	
(Requires use of MREL-01 option purchased separately)	139
PFA control	139
SPFC control	140
Settings	142
Diagnostics	143
Connection diagram example	144

11. Actual signals and parameters

Contents of this chapter	145
Terms and abbreviations	146
Fieldbus equivalent	146
Actual signals in the short parameter view	146
Parameters in the short parameter view	147
Parameter listing	150
Group 99: Start-up data	150
Group 01: Operating data	152
Group 03: FB actual signals	157
Group 04: Fault history	161
Group 10: Start/Stop/Dir	162
Group 11: Reference select	164
Group 12: Constant speeds	170
Group 13: Analogue inputs	175
Group 14: Relay outputs	176
Group 15: Analogue outputs	180
Group 16: System controls	181
Group 17: Override	187
Group 18: Freq in & tran out	190
Group 20: Limits	193
Group 21: Start/Stop	194
Group 22: Accel/Decel	197
Group 25: Critical speeds	200
Group 26: Motor control	201
Group 29: Maintenance trig	204
Group 30: Fault functions	205
Group 31: Automatic reset	210
Group 32: Supervision	212
Group 33: Information	214
Group 34: Panel display	215
Group 35: Motor temp meas	219
Group 36: Timed functions	220
Group 37: User load curve	226
Group 40: Process PID set 1	228
Group 41: Process PID set 2	245



Group 42: Ext / Trim PID	245
Group 44: Pump protection	248
Group 45: Energy saving	253
Group 46: Pump cleaning	255
Group 52: Panel comm	257
Group 53: EFB protocol	258
Group 64: Load analyzer	260
Group 81: PFA control	263
Group 98: Options	280
Default values with different macros	281

12. Fieldbus control

Contents of this chapter	285
System overview	285
Control interface	287
Planning	287
Mechanical and electrical installation – EFB	288
Communication set-up – EFB	290
Serial communication selection	290
Serial communication configuration	290
Activate drive control functions – EFB	294
Controlling the drive	294
Start/Stop direction control	294
Input reference select	295
Miscellaneous drive control	296
Relay output control	297
Analog output control	298
PID control setpoint source	298
Communication fault	298
Feedback from the drive – EFB	299
Pre-defined feedback	299
Mailbox Read/Write	299
Actual value scaling	300
Diagnostics – EFB	301
Fault queue for drive diagnostics	301
Serial communication diagnostics	301
Diagnostic situations	301
N2 protocol technical data	304
Overview	304
N2 analog input objects	307
N2 binary input objects	308
N2 analog output objects	308
N2 binary output objects	309
DDL file for NCU	310
FLN protocol technical data	313
Overview	313
Reports	313
Scaling drive feedback values	317
Loop gains	318
Point database	318



12 Table of contents

Detailed point descriptions	321
BACnet protocol technical data	327
Binary input object instance summary	327
Binary output object instance summary	327
Binary value object instance summary	328
Analog input object instance summary	330
Analog output object instance summary	330
Analog value object instance summary	331
BACnet quick-start sequence	333
BACnet protocol implementation conformance statement (PICS)	334
BACnet Standard Device Profile	334
Services Supported	334
Data Link Layer options	334
MAC ID / Device Object Instance	334
Max Info Frames Property	334
Max Master Property	335
MS/TP Token Counter	335
BACnet protocol implementation conformance statement	335
BACnet object definitions	337
Object/Property support matrix	337
Modbus protocol technical data	338
Overview	338
Modbus addressing	340
ABB control profiles technical data	347
Overview	347
Status word	351
State diagram	355
Reference scaling	357

13. Fault tracing

Contents of this chapter	361
Safety	361
Alarm and fault indications	361
How to reset	361
Fault history	362
Alarm messages generated by the drive	363
Alarms generated by the Basic control panel	367
Fault messages generated by the drive	370
Embedded fieldbus faults	377
No master device	377
Same device address	377
Incorrect wiring	377

14. Maintenance and hardware diagnostics

Contents of this chapter	379
Maintenance intervals	379
Cooling fan	380
Replacing the cooling fan (frame sizes R1...R4)	380
Capacitors	382

Reforming the capacitors	382
Power connections	382
Control panel	382
Cleaning the control panel	382
Changing the battery in the Assistant control panel	382
LEDs	383

15. Technical data

Contents of this chapter	385
Ratings	386
Definitions	387
Sizing	388
Derating	388
Fuses and alternate short-circuit protection	390
Fuses	390
Alternate short-circuit protection	390
Fuses and MMPs	391
Size of copper conductor in cabling	393
Dimensions, weights and free space requirements	394
Dimensions and weights	394
Free space requirements	394
Losses, cooling data and noise	395
Losses and cooling data	395
Noise	396
Terminal and lead-through data for the power cables	396
Terminal and lead-through data for the control cables	396
Electric power network specification	397
Motor connection data	397
Control connection data	398
Clearance and creepage distance	398
Efficiency	398
Degrees of protection	398
Ambient conditions	399
Materials	400
Applicable standards	400
CE marking	401
Compliance with the European EMC Directive	401
Compliance with EN 61800-3:2004	401
Definitions	401
Category C2	402
Category C3	402
UL marking	403
UL checklist	403
C-Tick marking	403
RoHS marking	404

16. Dimension drawings

Contents of this chapter	405
Frame sizes R0 and R1, IP20 (cabinet installation) / UL open	406



14 Table of contents

Frame sizes R0 and R1, IP20 / NEMA 1	407
Frame size R2, IP20 (cabinet installation) / UL open	408
Frame size R2, NEMA 1	409
Frame size R3, IP20 (cabinet installation) / UL open	410
Frame size R3, NEMA 1	411
Frame size R4, IP20 (cabinet installation) / UL open	412
Frame size R4, NEMA 1	413

17. Index

Further information

Product and service inquiries	29
Product training	29
Providing feedback on ABB Drives manuals	29
Document library on the Internet	29



1

Safety

Contents of this chapter

The chapter contains safety instructions which you must follow when installing, operating and servicing the drive. If ignored, physical injury or death may follow, or damage may occur to the drive, motor or driven equipment. Read the safety instructions before you work on the drive.



Use of warning symbols

Warnings caution you about conditions which can result in serious injury or death and/or damage to the equipment, and advise on how to avoid the danger. The following warning symbols are used in this manual:



WARNING! Danger; electricity warns of hazards from electricity which can cause physical injury and/or damage to the equipment.



WARNING! General danger warns about conditions, other than those caused by electricity, which can result in physical injury and/or damage to the equipment.

Safety in installation and maintenance

These warnings are intended for all who work on the drive, motor cable or motor.

■ Electrical safety



WARNING! If you ignore the safety instructions, injury or death can occur. If you are not a qualified electrician, do not do electrical work.

- Only qualified electricians are allowed to install and maintain the drive!
- Never work on the drive, motor cable or motor when input power is applied. After disconnecting the input power, always wait for 5 minutes to let the intermediate circuit capacitors discharge before you start working on the drive, motor or motor cable.
- Always ensure by measuring with a multimeter (impedance at least 1 Mohm) that there is no voltage between the drive input phases U1, V1 and W1 and the ground.
- Do not work on the control cables when power is applied to the drive or to the external control circuits. Externally supplied control circuits may carry dangerous voltage even when the input power of the drive is switched off.
- Do not make any insulation or voltage withstand tests on the drive.
- Disconnect the internal EMC filter when installing the drive on an IT system (an ungrounded power system or a high-resistance-grounded [over 30 ohms] power system), otherwise the system is connected to ground potential through the EMC filter capacitors. This may cause danger or damage the drive. See page 49. **Note:** When the internal EMC filter is disconnected, the drive is not EMC compatible.
- Disconnect the internal EMC filter when installing the drive on a corner-grounded TN system, otherwise the drive will be damaged. See page 49. **Note:** When the internal EMC filter is disconnected, the drive is not EMC compatible.
- All ACS320 Drive End Grounding screws are removed at the factory. See [Product overview](#) for location details.
- All ELV (extra low voltage) circuits connected to the drive must be used within a zone of equipotential bonding, in other words, within a zone where all simultaneously accessible conductive parts are electrically connected to prevent hazardous voltages appearing between them. This is accomplished by a proper factory grounding.

Notes:

- Even when the motor is stopped, dangerous voltage is present at the power circuit terminals U1, V1, W1 and U2, V2, W2.
 - For more technical information, contact the factory or your local ABB sales representative.
-

■ General safety



WARNING! If you ignore the safety instructions, injury or death can occur. If you are not a qualified electrician, do not do electrical work.

- Never attempt to repair a malfunctioning drive; contact your local ABB representative or Authorized Service Center for service support.
- Make sure that dust from drilling does not enter the drive during the installation. Electrically conductive dust inside the drive may cause damage or lead to malfunction.
- Ensure sufficient cooling.

Safe start-up and operation



These warnings are intended for all who plan the operation, start up or operate the drive.

■ General safety





WARNING! If you ignore the safety instructions, injury or death can occur. If you are not a qualified electrician, do not do electrical work.



- Before adjusting the drive and putting it into service, make sure that the motor and all driven equipment are suitable for operation throughout the speed range provided by the drive. The drive can be adjusted to operate the motor at speeds above and below the speed provided by connecting the motor directly to the power line.
- Before you activate the automatic fault reset or automatic restart functions of the drive control program, make sure that no dangerous situations can occur. These functions reset the drive automatically and continue operation after a fault or supply break. If these functions are activated, the installation must be clearly marked as defined in IEC/EN 61800-5-1, subclause 6.5.3, for example, "THIS MACHINE STARTS AUTOMATICALLY".
- Do not control the drive with an AC contactor or disconnecting device (disconnecting means); use the control panel start and stop keys  and  or external commands (I/O or fieldbus). The maximum allowed number of charging cycles of the DC capacitors (in other words, power-ups by applying power) is two per minute and the maximum total number of chargings is 15,000.

Notes:

- If an external source for start command is selected and it is ON, the drive will start immediately after an input voltage break or fault reset unless the drive is configured for 3-wire (a pulse) start/stop.
- When the control location is not set to local (LOC not shown on the display), the stop key on the control panel will not stop the drive. To stop the drive using the control panel, first press the LOC/REM key  and then the stop key .





2

Introduction to the manual

Contents of this chapter

The chapter describes applicability, target audience and purpose of this manual. It describes the contents of this manual and refers to a list of related manuals for more information. The chapter also contains a flowchart of steps for checking the delivery, installing and commissioning the drive. The flowchart refers to chapters/sections in this manual.

Applicability

The manual is applicable to the ACS320 drive firmware version 4.03c or later. See parameter [3301 FIRMWARE](#) on page [214](#).

Target audience

The reader is expected to know the fundamentals of electricity, wiring, electrical components and electrical schematic symbols.

The manual is written for readers worldwide. Both SI and imperial units are shown. Special US instructions for installations in the United States are given.

Purpose of the manual

This manual provides information needed for planning the installation, installing, commissioning, using and servicing the drive.

Contents of this manual

The manual consists of the following chapters:

- [Safety](#) (page 15) gives safety instructions you must follow when installing, commissioning, operating and servicing the drive.
 - [Introduction to the manual](#) (this chapter, page 19) describes applicability, target audience, purpose and contents of this manual. It also contains a quick installation and commissioning flowchart.
 - [Operation principle and hardware description](#) (page 23) describes the operation principle, layout, power connections and control interfaces, type designation label and type designation information in short.
 - [Mechanical installation](#) (page 29) tells how to check the installation site, unpack, check the delivery and install the drive mechanically.
 - [Planning the electrical installation](#) (page 35) tells how to check the compatibility of the motor and the drive and select cables, protections and cable routing.
 - [Electrical installation](#) (page 47) tells how to check the insulation of the assembly and the compatibility with IT (ungrounded) and corner grounded TN systems as well as connect power cables, control cables and embedded fieldbus.
 - [Installation checklist](#) (page 59) contains a checklist for checking the mechanical and electrical installation of the drive.
 - [Start-up](#) (page 61) tells how to start up the drive as well as how to start, stop, change the direction of the motor rotation and adjust the motor speed through the I/O interface. In addition, the chapter gives a brief description of each application macro together with a wiring diagram showing the default control connections. It also explains how to save a user macro and how to recall it.
 - [Application macros](#) (page 81) gives a brief description of each application macro together with a wiring diagram showing the default control connections. It also explains how to save a user macro and how to recall it.
 - [Program features](#) (page 101) describes program features with lists of related user settings, actual signals, and fault and alarm messages.
 - [Actual signals and parameters](#) (page 145) describes actual signals and parameters. It also lists the default values for the different macros.
 - [Fieldbus control](#) (page 285) tells how the drive can be controlled by external devices over a communication network using embedded fieldbus
 - [Fault tracing](#) (page 361) tells how to reset faults and view fault history. It lists all alarm and fault messages including the possible cause and corrective actions.
 - [Maintenance and hardware diagnostics](#) (page 379) contains preventive maintenance instructions and LED indicator descriptions.
 - [Technical data](#) (page 385) contains technical specifications of the drive, for example, ratings, sizes and technical requirements as well as provisions for fulfilling the requirements for CE and other marks.
 - [Dimension drawings](#) (page 405) shows dimension drawings of the drive.
-

Related documents

See [List of related manuals](#) on page 2.

Categorization by frame size

The ACS320 drive is manufactured in frame sizes R0...R4. Some instructions and other information which only concern certain frame sizes are marked with the symbol of the frame size (R0...R4). To identify the frame size of your drive, see the table in section [Ratings](#) on page 386 or in section [Definitions](#) on page 387.

Quick installation and commissioning flowchart

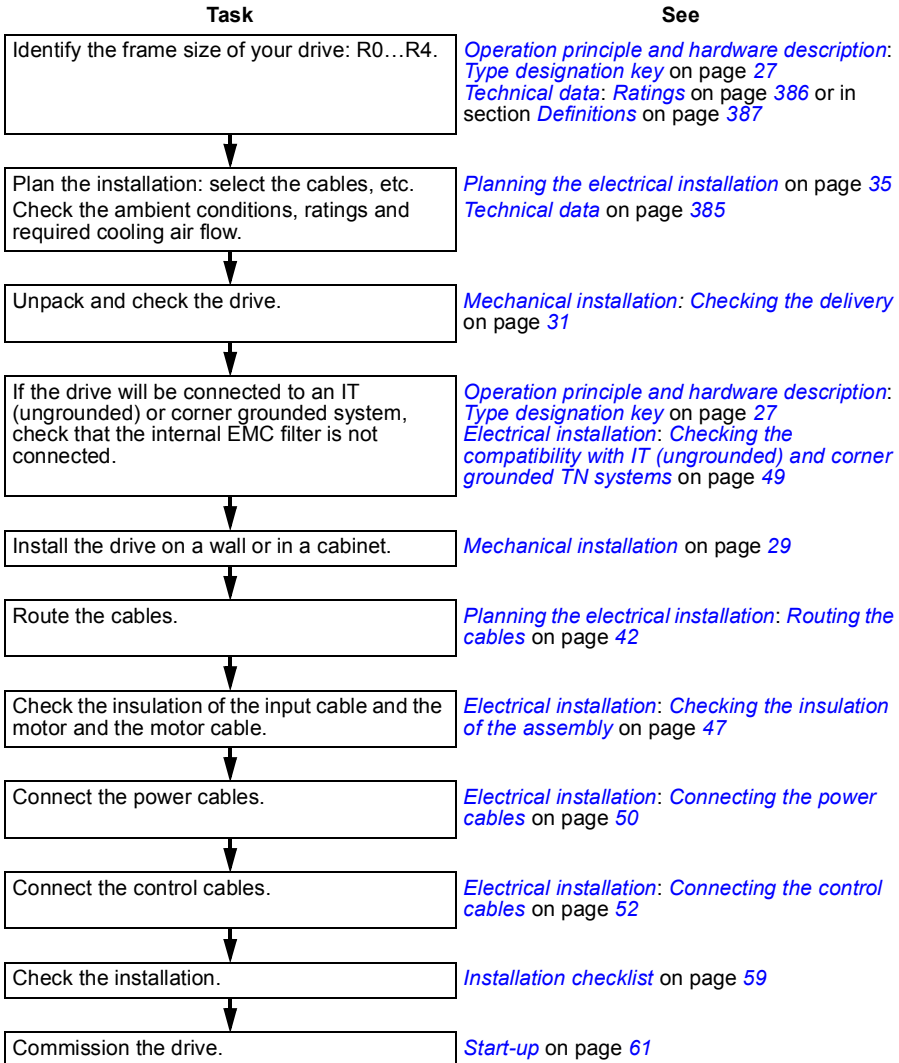

3

Operation principle and hardware description

Contents of this chapter

The chapter briefly describes the operation principle, layout, type designation label and type designation information. It also shows a general diagram of power connections and control interfaces.

Operation principle

The ACS320 is a wall or cabinet mountable drive for controlling AC motors.

The figure below shows the simplified main circuit diagram of the drive. The rectifier converts three-phase AC voltage to DC voltage. The capacitor bank of the intermediate circuit stabilizes the DC voltage. The inverter converts the DC voltage back to AC voltage for the AC motor.

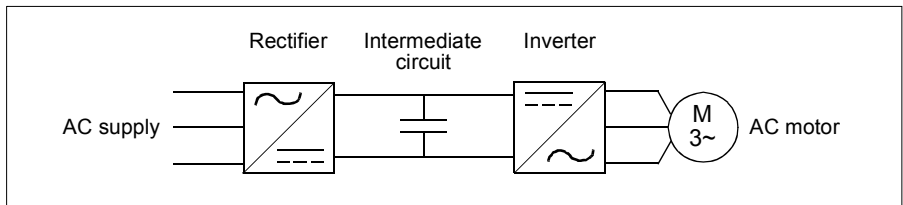

Product overview

Layout

The layout of the drive is presented below. The figure shows a frame size R2 drive. The construction of the different frame sizes R0...R4 varies to some extent.

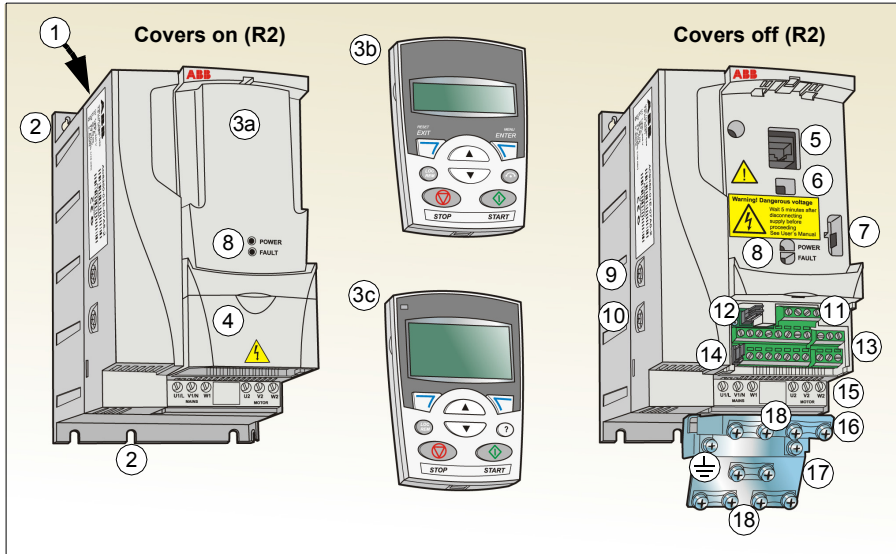

1	Cooling outlet through top cover
2	Mounting holes
3	Panel cover (a) / Basic control panel (b) / Assistant control panel (c)
4	Terminal cover
5	Panel connection
6	Option connection
7	FlashDrop connection
8	Power OK and Fault LEDs. See section LEDs on page 383.

9	EMC filter grounding screw (EMC). Note: The screw is on the front in frame size R4.
10	Varistor grounding screw (VAR). See section Protecting the contacts of relay outputs on page 45.
11	EIA-485 connection
12	Jumper J701 for connecting EIA-485 termination resistor
13	I/O connections
14	Jumper S1 for selecting voltage or current for analog inputs
15	Input power connection (U1, V1, W1) and motor connection (U2, V2, W2). (Braking chopper connection is disabled.)
16	I/O clamping plate
17	Clamping plate
18	Clamps

Power connections and control interfaces

The diagram gives an overview of connections. I/O connections are parameterable.

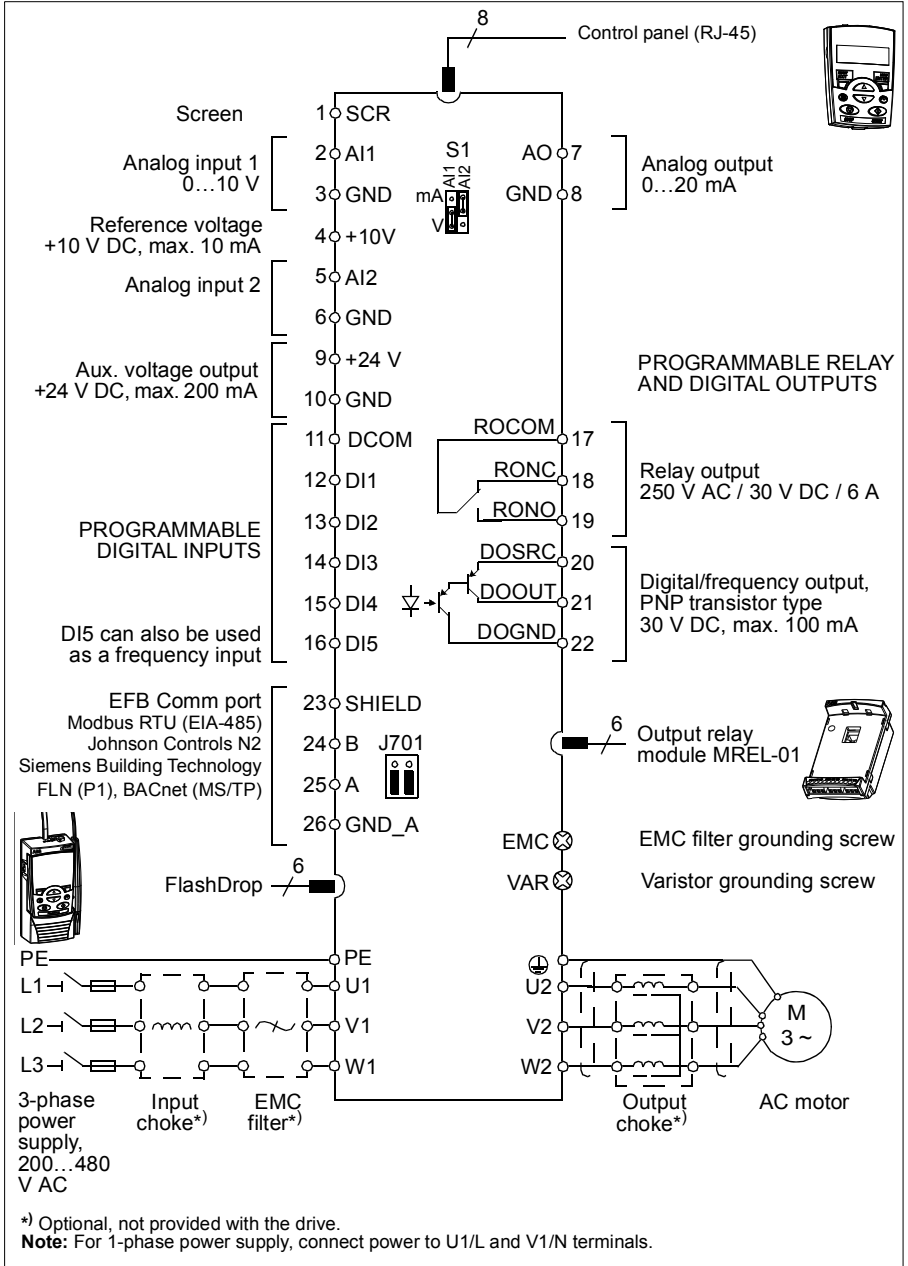

See [Application macros](#) on page 81 for I/O connections for the different macros and chapter [Electrical installation](#) on page 47 for installation in general.

Type designation label

The type designation label is attached to the left side of the drive. An example label and explanation of the label contents are shown below.

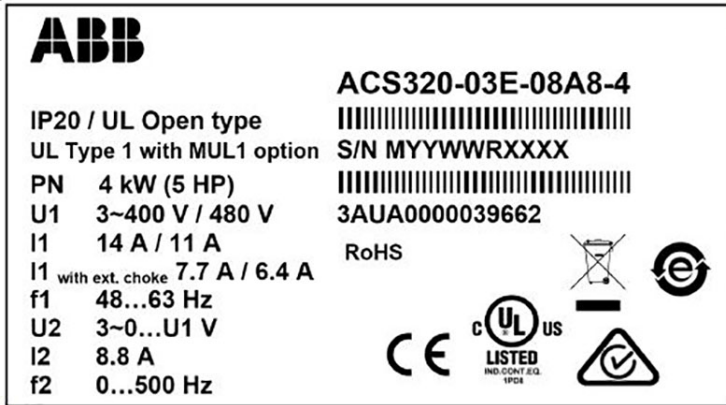

1	Type designation, see section Type designation key on page 27
2	Degree of protection by enclosure (IP and UL/NEMA)
3	Nominal ratings, see section Ratings on page 386 or Definitions on page 387.
4	Serial number of format MYYWWRXXXX, where M: Manufacturer YY: 09, 10, 11, ... for 2009, 2010, 2011, ... WW: 01, 02, 03, ... for week 1, week 2, week 3, ... R: A, B, C, ... for product revision number XXXX: Integer starting every week from 0001
5	ABB MRP code of the drive
6	CE marking and C-Tick, C-UL US and RoHS marks (the label of your drive shows the valid markings)

Type designation key

The type designation contains information on the specifications and configuration of the drive. You find the type designation on the type designation label attached to the drive. The first digits from the left express the basic configuration, for example ACS320-03U-09A7-4. The optional selections are given after that, separated by + signs, for example +J404. The explanations of the type designation selections are described below.

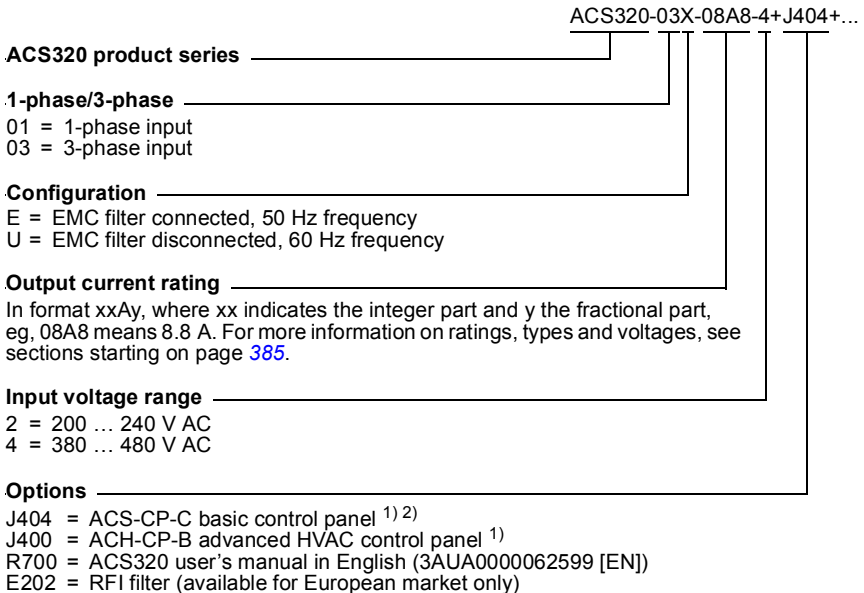

1) The ACS320 is compatible with panels that have the following panel revisions and panel firmware versions.

Panel type	Type code	Panel revision	Panel firmware version
Basic control panel ²⁾	ACS-CP-C	M or later	1.13 or later
Advanced HVAC control panel	ACH-CP-B	X or later	2.04 or later

2) Available for North American market only.

4

Mechanical installation

Contents of this chapter

The chapter tells how to check the installation site, unpack, check the delivery and install the drive mechanically.

Checking the installation site

The drive may be installed on the wall or in a cabinet. Check the enclosure requirements for the need to use the NEMA 1 option in wall installations (see chapter [Technical data](#) on page 385).

The drive can be installed in three different ways, depending on the frame size:

- a) back mounting (all frame sizes)
- b) side mounting (frame sizes R0...R2)
- c) DIN rail mounting (all frame sizes).

The drive must be installed in an upright position.

Check the installation site according to the requirements below. Refer to chapter [Dimension drawings](#) on page 405 for frame details.

■ Requirements for the installation site

Operation conditions

See chapter [Technical data](#) on page 385 for the allowed operation conditions of the drive.

Wall

The wall should be as close to vertical and even as possible, of non-flammable material and strong enough to carry the weight of the drive.



Floor

The floor/material below the installation should be non-flammable.

Free space around the drive

The required free space for cooling above and below the drive is 75 mm (3 in). No free space is required on the sides of the drive, so drives can be installed side by side.

Required tools

To install the drive, you need the following tools:

- screwdrivers (as appropriate for the mounting hardware used)
- wire stripper
- tape measure
- drill (if the drive will be installed with screws/bolts)
- mounting hardware: screws or bolts (if the drive will be installed with screws/bolts). For the number of screws/bolts, see [With screws](#) on page 32.



Unpacking

The drive (1) is delivered in a package that also contains the following items (frame size R2 shown in the figure):

- plastic bag (2) including clamping plate (also used for I/O cables in frame sizes R3 and R4), I/O clamping plate (for frame sizes R0...R2), clamps and screws
- panel cover (3)
- mounting template, integrated into the package (4)
- user's manual (5)
- possible options.

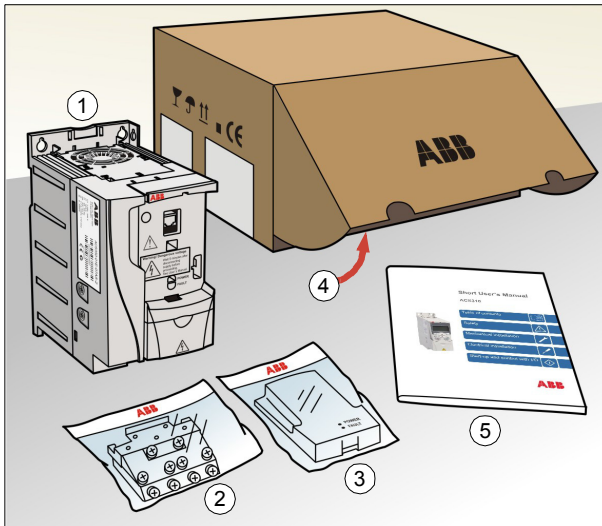

Checking the delivery

Check that there are no signs of damage. Notify the shipper immediately if damaged components are found.

Before attempting installation and operation, check the information on the type designation label of the drive to verify that the drive is of the correct type. See section [Type designation label](#) on page 26.



Installing

The instructions in this manual cover drives with the IP20 degree of protection. To comply with NEMA 1, use the MUL-R1, MUL-R3 or MUL-R4 option kit, which is delivered with multilingual installation instructions (3AFE68642868, 3AFE68643147 or 3AUA0000025916, respectively).

■ Install the drive

Install the drive with screws or on a DIN rail as appropriate.

Note: Make sure that dust from drilling does not enter the drive during the installation.

With screws

1. Mark the hole locations using for example the mounting template cut out from the package.

The locations of the holes are also shown in the drawings in chapter *Dimension drawings* on page 405. The number and location of the holes used depend on how the drive is installed:

- a) back mounting (frame sizes R0...R4): four holes
 - b) side mounting (frame sizes R0...R2): three holes; one of the bottom holes is located in the clamping plate.
2. Fix the screws or bolts to the marked locations.

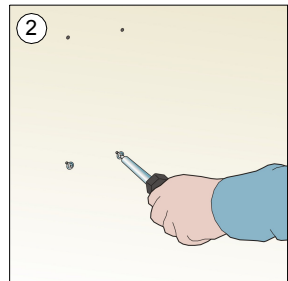
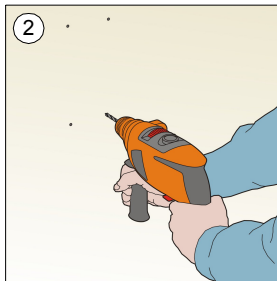
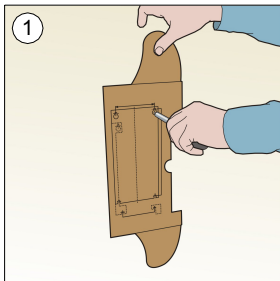

3. Position the drive onto the screws on the wall.
4. Tighten the screws in the wall securely.

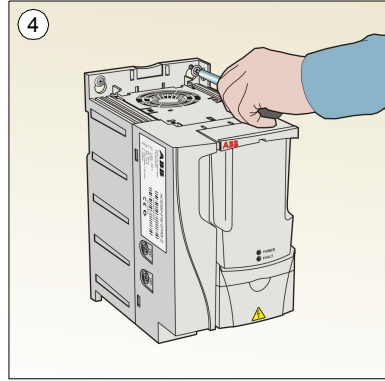
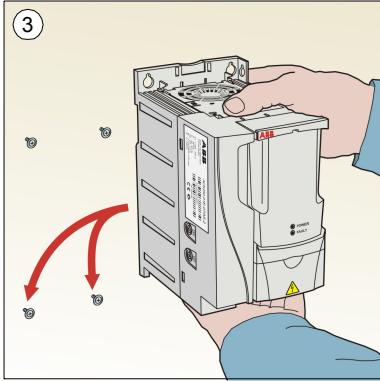

On DIN rail

- Click the drive to the rail.
- To detach the drive, press the release lever on top of the drive (1b).

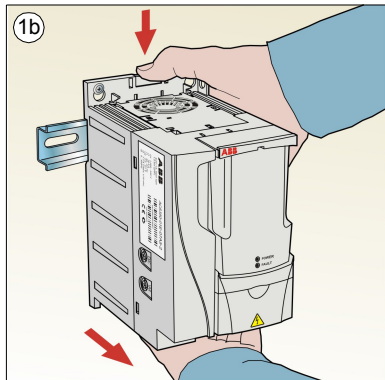
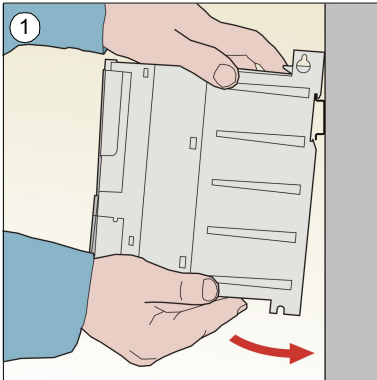

■ Fasten clamping plates

1. Fasten the clamping plate to the plate at the bottom of the drive with the provided screws.
2. For frame sizes R0...R2, fasten the I/O clamping plate to the clamping plate with the provided screws.

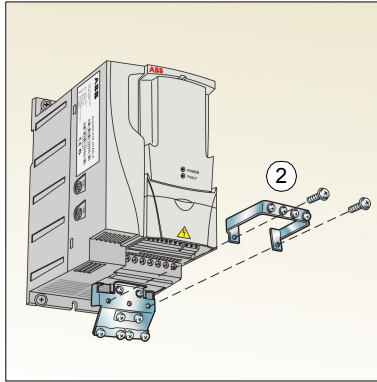
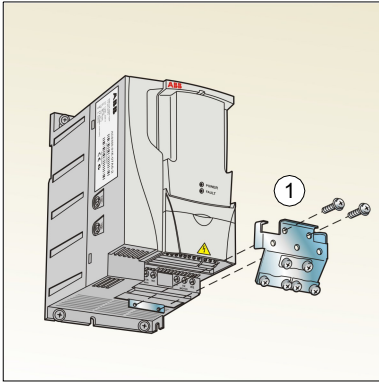

5

Planning the electrical installation

Contents of this chapter

The chapter contains the instructions that you must follow when checking the compatibility of the motor and drive, and selecting cables, protections, cable routing and way of operation for the drive.

Note: The installation must always be designed and made according to applicable local laws and regulations. ABB does not assume any liability whatsoever for any installation which breaches the local laws and/or other regulations. Furthermore, if the recommendations given by ABB are not followed, the drive may experience problems that the warranty does not cover.

Implementing the AC power line connection

See the requirements in section [Electric power network specification](#) on page 397. Use a fixed connection to the AC power line.



WARNING! As the leakage current of the device typically exceeds 3.5 mA, a fixed installation is required according to IEC 61800-5-1.

Selecting the supply disconnecting device (disconnecting means)

Install a hand-operated supply disconnecting device (disconnecting means) between the AC power source and the drive. The disconnecting device must be of a type that can be locked to the open position for installation and maintenance work.

■ European union

To meet the European Union Directives, according to standard EN 60204-1, Safety of Machinery, the disconnecting device must be one of the following types:

- a switch-disconnector of utilization category AC-23B (EN 60947-3)
- a disconnector having an auxiliary contact that in all cases causes switching devices to break the load circuit before the opening of the main contacts of the disconnector (EN 60947-3)
- a circuit breaker suitable for isolation in accordance with EN 60947-2.

■ North America

The ACS320 drive does not include a disconnect device. A means to disconnect input power must be installed between the AC power source and the ACS320 drive. This branch circuit protection must:

- be sized to conform to applicable safety regulations, including but not limited to, both National and local electrical codes.
- be locked in an open position during installation and maintenance work.

The disconnect device must not be used to control the motor. Instead use the control panel, or commands to the I/O terminals for motor control.

■ Other regions

The disconnecting device must conform to the applicable safety regulations.

Checking the compatibility of the motor and drive

Check that the 3-phase AC induction motor and the drive are compatible according to the rating table in section [Ratings](#) on page [386](#) or in section [Definitions](#) on page [387](#). The table lists the typical motor power for each drive type.

Selecting the power cables

■ General rules

Dimension the input power and motor cables **according to local regulations**.

- The input power and the motor cables must be able to carry the corresponding load currents. See section [Ratings](#) on page [386](#) or in section [Definitions](#) on page [387](#) for the rated currents.
- The cable must be rated for at least 70 °C maximum permissible temperature of the conductor in continuous use. For US, see section [Additional North American requirements](#) on page [39](#).
- The conductivity of the PE conductor must be equal to that of the phase conductor (same cross-sectional area).
- 600 V AC cable is accepted for up to 500 V AC.
- Refer to chapter [Technical data](#) on page [385](#) for the EMC requirements.

A symmetrical shielded motor cable (see the figure below) must be used to meet the EMC requirements of the CE and C-Tick marks.

A four-conductor system is allowed for input cabling, but a shielded symmetrical cable is recommended.

Compared to a four-conductor system, the use of a symmetrical shielded cable reduces electromagnetic emission of the whole drive system as well as motor bearing currents and wear.

Alternative power cable types

Power cable types that can be used with the drive are presented below.

Motor cables

(recommended for input cables also)

Symmetrical shielded cable: three phase conductors, a concentric or otherwise symmetrically constructed PE conductor and a shield

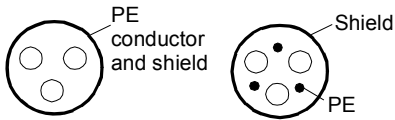

Note: A separate PE conductor is required if the conductivity of the cable shield is not sufficient for the purpose.

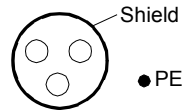

Allowed as input cables

A four-conductor system: three phase conductors and a protective conductor

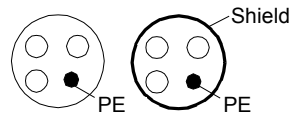

■ Motor cable shield

To function as a protective conductor, the shield must have the same cross-sectional area as the phase conductors when they are made of the same metal.

To effectively suppress radiated and conducted radio-frequency emissions, the shield conductivity must be at least 1/10 of the phase conductor conductivity. The requirements are easily met with a copper or aluminium shield. The minimum requirement of the motor cable shield of the drive is shown below. It consists of a concentric layer of copper wires. The better and tighter the shield, the lower the emission level and bearing currents.

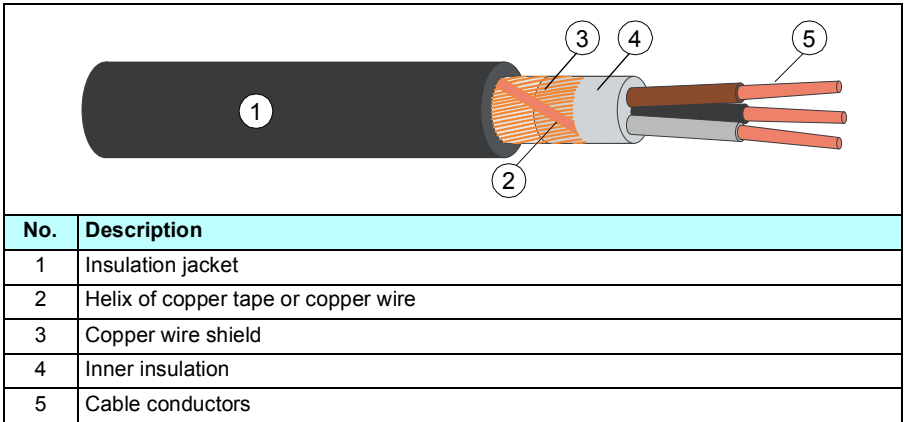

■ Additional North American requirements

Type MC continuous corrugated aluminum armor cable with symmetrical grounds or shielded power cable is recommended for the motor cables if metallic conduit is not used.

The power cables must be rated for 75 °C (167 °F).

Conduit

Where conduits must be coupled together, bridge the joint with a ground conductor bonded to the conduit on each side of the joint. Bond the conduits also to the drive enclosure. Use separate conduits for input power, motor and control wiring. Do not run motor wiring from more than one drive in the same conduit.

Armored cable / shielded power cable

Six-conductor (three phases and three ground) type MC continuous corrugated aluminium armor cable with symmetrical grounds is available from the following suppliers (trade names in parentheses):

- Anixter Wire & Cable (Philsheath)

- BICC General Corp (Philsheath)
- Rockbestos Co. (Gardex)
- Oaknite (CLX).

Shielded power cable is available from the following suppliers:

- Belden
 - LAPPKABEL (ÖLFLEX)
 - Pirelli.
-

Selecting the control cables

■ General rules

All analog control cables and the cable used for the frequency input must be shielded.

Use a double-shielded twisted pair cable (figure a, for example JAMAK by Draka NK Cables) for analog signals. Employ one individually shielded pair for each signal. Do not use common return for different analog signals.

A double-shielded cable is the best alternative for low-voltage digital signals, but a single-shielded or unshielded twisted multipair cable (figure b) is also usable. However, for frequency input, always use a shielded cable.

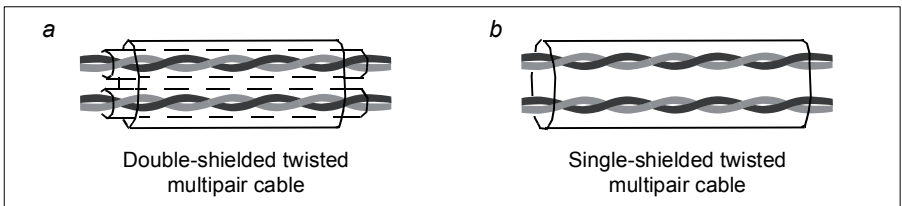

Run analog and digital signals in separate cables.

Relay-controlled signals, providing their voltage does not exceed 48 V, can be run in the same cables as digital input signals. It is recommended that the relay-controlled signals are run as twisted pairs.

Never mix 24 V DC and 115/230 V AC signals in the same cable.

■ Relay cable

The cable type with braided metallic screen (for example ÖLFLEX by LAPPKABEL) has been tested and approved by ABB.

■ Control panel cable

In remote use, the cable connecting the control panel to the drive must not exceed 3 m (10 ft). The cable type tested and approved by ABB is used in control panel option kits.

Routing the cables

Route the motor cable away from other cable routes. Motor cables of several drives can be run in parallel installed next to each other. It is recommended that the motor cable, input power cable and control cables are installed on separate trays. Avoid long parallel runs of motor cables with other cables to decrease electromagnetic interference caused by the rapid changes in the drive output voltage.

Where control cables must cross power cables make sure that they are arranged at an angle as near to 90 degrees as possible.

The cable trays must have good electrical bonding to each other and to the grounding electrodes. Aluminium tray systems can be used to improve local equalizing of potential.

A diagram of the cable routing is shown below.

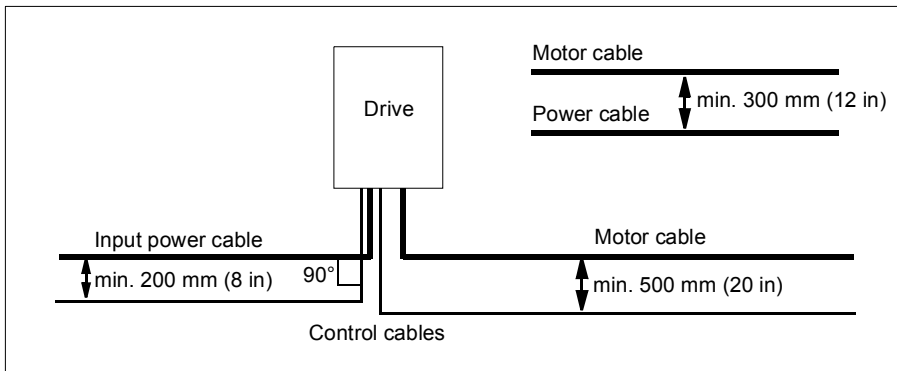

Control cable ducts

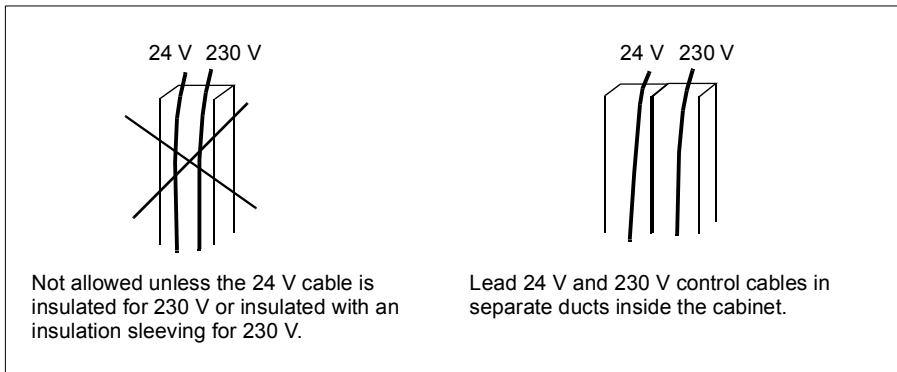

Protecting the drive, input power cable, motor and motor cable in short circuit situations and against thermal overload

■ Protecting the drive and input power cable in short-circuit situations

Arrange the protection according to the following guidelines.

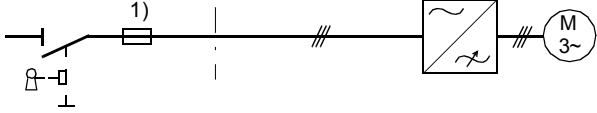
Circuit diagram			Short-circuit protection
Distribution board	Input cable	Drive	Protect the drive and input cable with fuses or ABB manual motor starter.
			

Size the fuses according to instructions given in chapter [Technical data](#) on page 385. The fuses will protect the input cable in short-circuit situations, restrict drive damage and prevent damage to adjoining equipment in case of a short-circuit inside the drive.

■ Protecting the motor and motor cable in short-circuit situations

The drive protects the motor and motor cable in a short-circuit situation when the motor cable is dimensioned according to the nominal current of the drive. No additional protection devices are needed.

■ Protecting the motor against thermal overload

According to regulations, the motor must be protected against thermal overload and the current must be switched off when overload is detected. The drive includes a motor thermal protection function that protects the motor and switches off the current when necessary. It is also possible to connect a motor temperature measurement to the drive. The user can tune both the thermal model and the temperature measurement function further by parameters.

The most common temperature sensors are:

- motor sizes IEC180...225: thermal switch (for example Klixon)
- motor sizes IEC200...250 and larger: PTC or Pt100.

For more information on the thermal model, see section [Motor thermal protection](#) on page 120. For more information on the temperature measurement function see section [Motor temperature measurement through the standard I/O](#) on page 129.

Using residual current devices (RCD) with the drive

ACS320-03x drives are suitable to be used with residual current devices of Type B. Other measures for protection in case of direct or indirect contact, such as separation from the environment by double or reinforced insulation or isolation from the supply system by a transformer, can also be applied.

Implementing a bypass connection



WARNING! Never connect the supply power to the drive output terminals U2, V2 and W2. Power line voltage applied to the output can result in permanent damage to the drive.

If bypassing is required, employ mechanically or electrically interlocked contactors between the motor and the drive and between the motor and the power line. Make sure with interlocking that the contactors cannot be closed simultaneously. The installation must be clearly marked as defined in IEC/EN 61800-5-1, subclause 6.5.3, for example, "THIS MACHINE STARTS AUTOMATICALLY".

Protecting the contacts of relay outputs

Inductive loads (relays, contactors, motors) cause voltage transients when switched off.

Equip inductive loads with noise attenuating circuits (varistors, RC filters [AC] or diodes [DC]) in order to minimize the EMC emission at switch-off. If not suppressed, the disturbances may connect capacitively or inductively to other conductors in the control cable and form a risk of malfunction in other parts of the system.

Install the protective component as close to the inductive load as possible. Do not install protective components at the I/O terminal block.

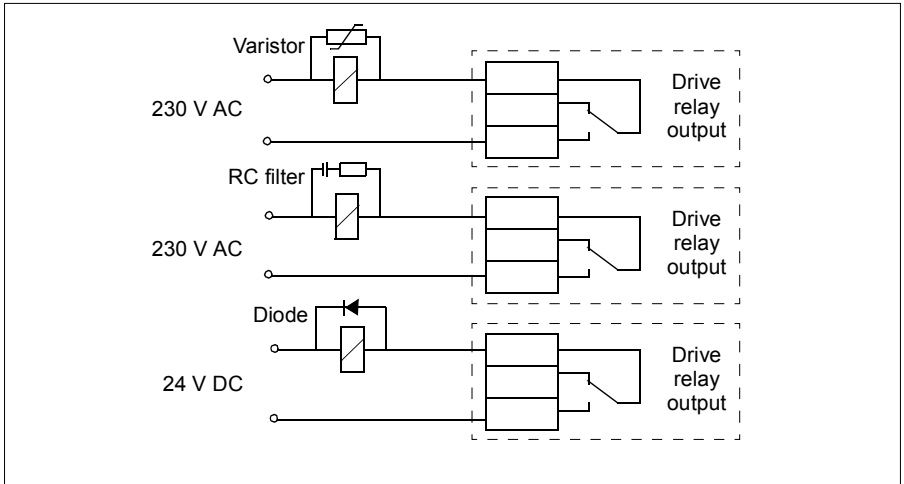

6

Electrical installation

Contents of this chapter

The chapter tells how to check the insulation of the assembly and the compatibility with IT (ungrounded) and corner grounded TN systems as well as connect power cables, control cables and embedded fieldbus.



WARNING! Obey the safety instructions. See chapter [Safety](#) on page 15. If you ignore the safety instructions, injury or death can occur. If you are not a qualified electrician, do not do electrical work. Make sure that the drive is disconnected from the input power during installation. If the drive is already connected to the input power, wait for 5 minutes after disconnecting the input power.

Checking the insulation of the assembly



■ Drive

Do not make any voltage tolerance or insulation resistance tests (for example hi-pot or megger) on any part of the drive as testing can damage the drive. Every drive has been tested for insulation between the main circuit and the chassis at the factory. Also, there are voltage-limiting circuits inside the drive which cut down the testing voltage automatically.

■ Input power cable

Check the insulation of the input power cable according to local regulations before connecting to the drive.

■ Motor and motor cable

Check the insulation of the motor and motor cable as follows:

1. Check that the motor cable is disconnected from the drive output terminals T1/U, T2/V and T3/W.
2. Measure the insulation resistance between the phase conductors and between each phase conductor and the Protective Earth (PE) conductor. Use a measuring voltage of 500 V DC. The insulation resistance of a motor must exceed 10 Mohm (reference value at 25 °C or 77 °F). For the insulation resistance of other motors, consult the manufacturer's instructions.

Note: Moisture inside the motor casing reduces the insulation resistance. If moisture is suspected, dry the motor and repeat the measurement.

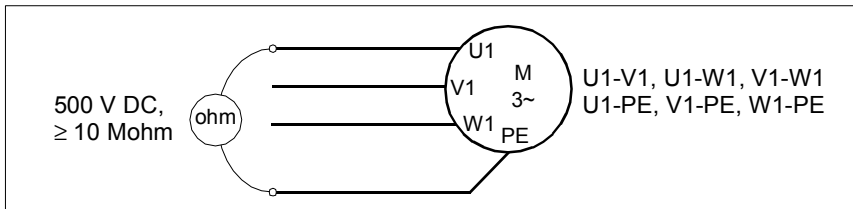

Checking the compatibility with IT (ungrounded) and corner grounded TN systems



WARNING! Disconnect the internal EMC filter when installing the drive on an IT system (an ungrounded power system or a high resistance-grounded [over 30 ohms] power system), otherwise the system will be connected to ground potential through the EMC filter capacitors. This may cause danger or damage the drive.

Disconnect the internal EMC filter when installing the drive on a corner-grounded TN system, otherwise the drive will be damaged.

Note: When the internal EMC filter is disconnected, the drive is not EMC compatible without an external filter.

1. If you have an IT (ungrounded) or corner grounded TN system, disconnect the internal EMC filter by removing the EMC screw. For 3-phase U-type drives (with type designation ACS320-03U-), the EMC screw is already removed at the factory and replaced by a plastic one.

Pay attention to the screws! Do not confuse the EMC screw to the similar varistor disconnecting screw. Do not disconnect the varistor. The varistor protects the drive against power line voltage peaks.

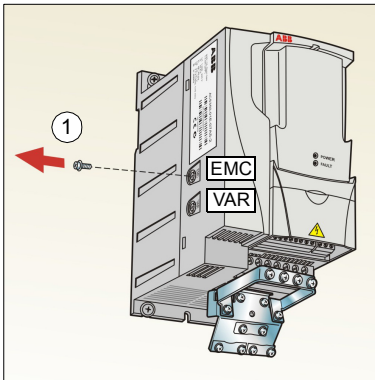

Note: In frame size R4 the EMC screw is located to the right of terminal W2.

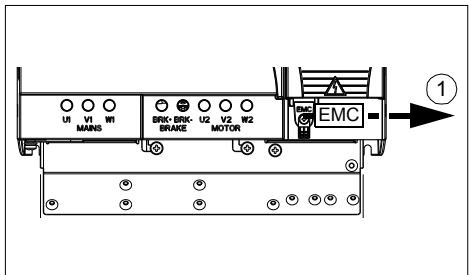

Connecting the power cables

■ Connection diagram

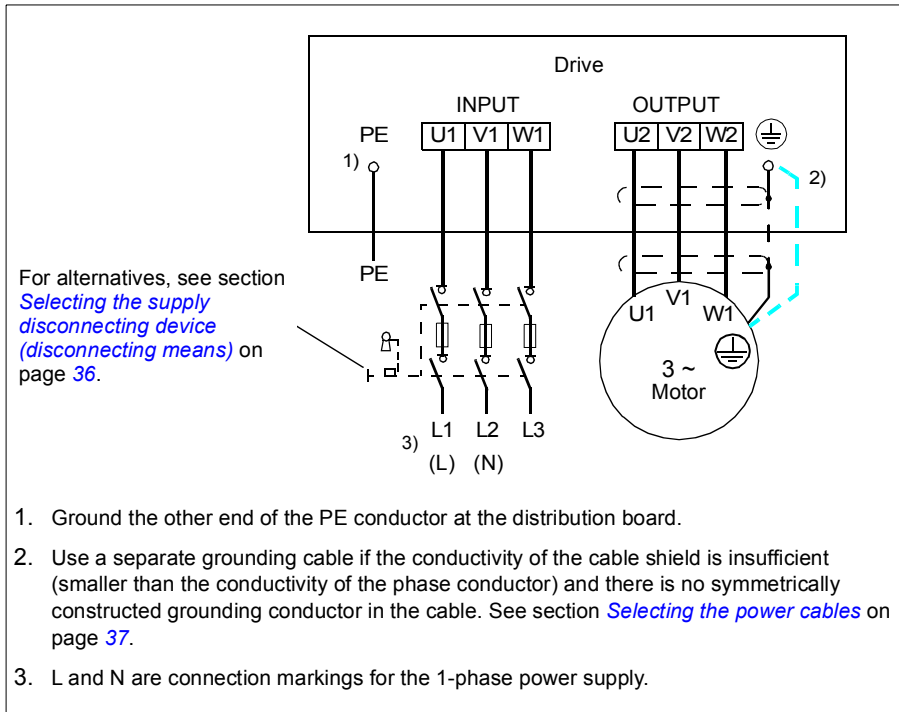

Notes:

- Do not use an asymmetrically constructed motor cable.
- If there is a symmetrically constructed grounding conductor in the motor cable in addition to the conductive shield, connect the grounding conductor to the grounding terminal at the drive and motor ends.
- Route the motor cable, input power cable and control cables separately. For more information, see section [Routing the cables](#) on page 42.

Grounding of the motor cable shield at the motor end

For minimum radio frequency interference:

- ground the cable by twisting the shield as follows: flattened width $\geq 1/5 \cdot \text{length}$
- or ground the cable shield 360 degrees at the lead-through of the motor terminal box.

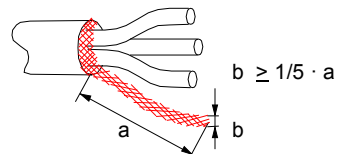

■ Connection procedure

1. Fasten the grounding conductor (PE) of the input power cable under the grounding clamp. Connect the phase conductors to the U1, V1 and W1 terminals. Use a tightening torque of 0.8 N·m (7 in-lb) for frame sizes R0...R2, 1.7 N·m (15 in-lb) for R3, and 2.5 N·m (22 in-lb) for R4.
2. Strip the motor cable and twist the shield to form as short a pigtail as possible. Fasten the twisted shield under the grounding clamp. Connect the phase conductors to the U2, V2 and W2 terminals. Use a tightening torque of 0.8 N·m (7 in-lb) for frame sizes R0...R2, 1.7 N·m (15 in-lb) for R3, and 2.5 N·m (22 in-lb) for R4.
3. Secure the cables outside the drive mechanically.

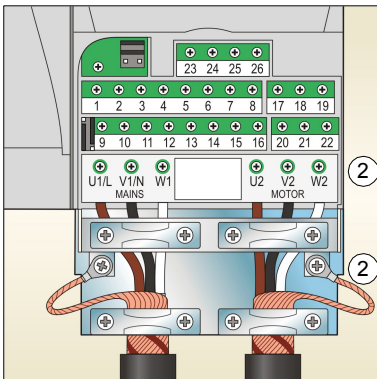
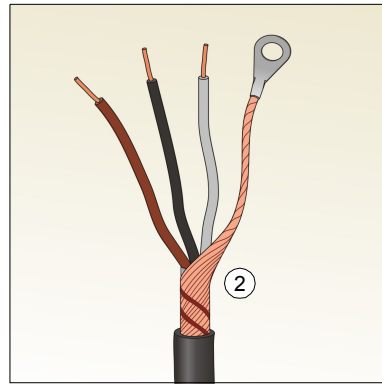
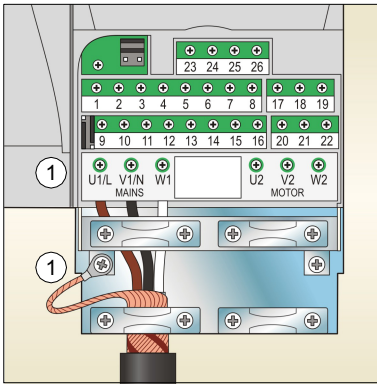

Connecting the control cables

I/O terminals

The figure below shows the I/O terminals. Tightening torque is 0.4 N·m / 3.5 in-lb.

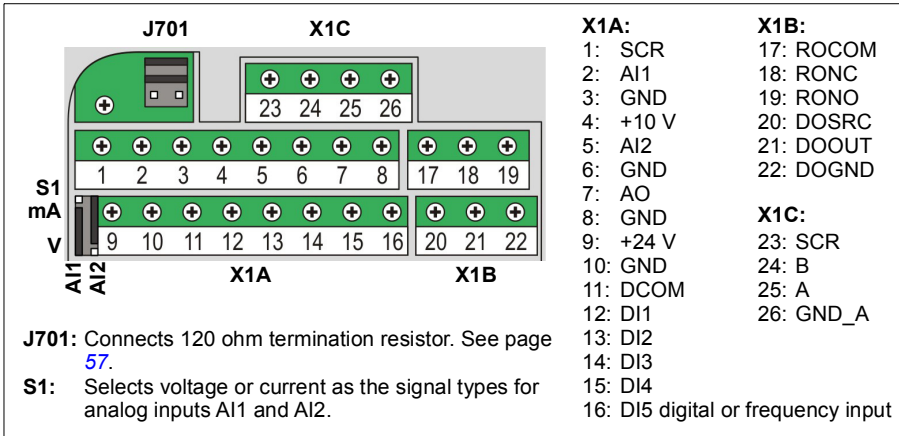

WARNING! All ELV (Extra Low Voltage) circuits connected to the drive must be used within a zone of equipotential bonding, in other words, within a zone where all simultaneously accessible conductive parts are electrically connected to prevent hazardous voltages appearing between them. This is accomplished by a proper factory grounding.

The terminals on the control board as well as on the optional modules attachable to the board fulfill the Protective Extra Low Voltage (PELV) requirements stated in EN 50178, provided that the external circuits connected to the terminals also fulfill the requirements and the installation site is below 2000 m (6562 ft).

Voltage and current selection for analog inputs

Jumper S1 selects voltage (0 [2]...10 V / -10...10 V) or current (0 [4]...20 mA / -20...20 mA) as the signal types for analog inputs AI1 and AI2. The factory settings are unipolar voltage for AI1 (0 [2]...10 V) and unipolar current for AI2 (0 [4]...20 mA), which correspond to the default usage in the application macros. The jumper is located to the left of I/O terminal 9 (see the I/O terminal figure above).

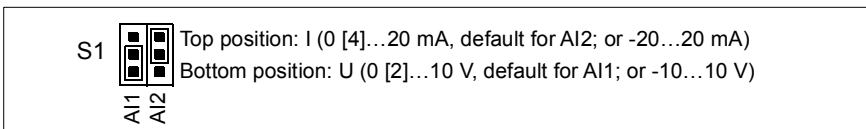

Permanently affix control cables with a minimum 1/4" spacing from power cables.

Voltage and current connection for analog inputs

Bipolar voltage (-10...10 V) and current (-20...20 mA) are also possible. If a bipolar connection is used instead of a unipolar one, see section [Programmable analog inputs](#) on page 109 for how to set parameters accordingly.

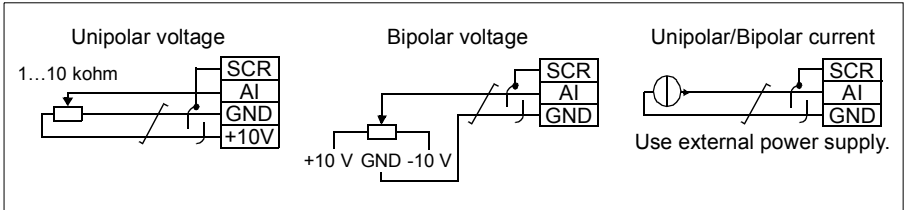

PNP and NPN configuration for digital inputs

You can wire the digital input terminals in either a PNP or NPN configuration.

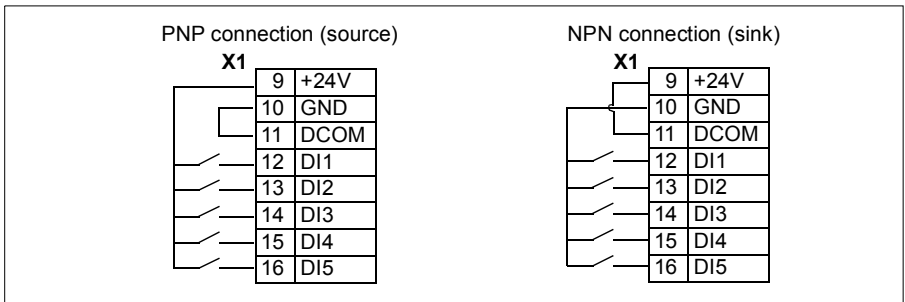

External power supply for digital inputs

For using an external +24 V supply for the digital inputs, see the figure below.

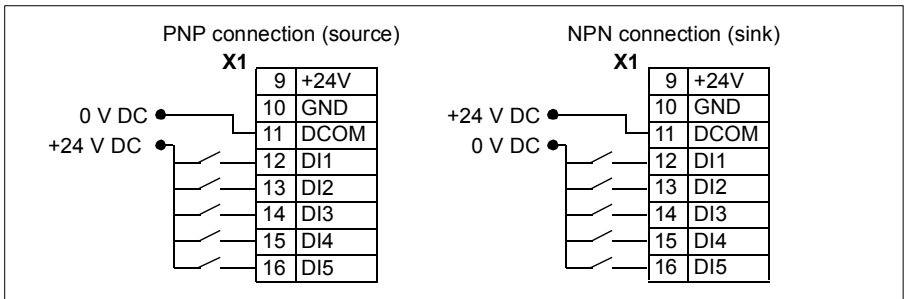

Frequency input

If DI5 is used as a frequency input, see section [Frequency input](#) on page 113 for how to set parameters accordingly.

Connection example of a two-wire sensor

HVAC default, supply fan, return fan, cooling tower fan, condenser, booster pumps, PFA control, internal timer, dual setpoint with PID, E-Clipse and dual setpoint with PID and constant speeds macros (see section [Application macros](#) on page 81) use analog input 2 (AI2). The macro wiring diagrams for these macros show the connection when a separately powered sensor is used. The figure below gives an example of a connection using a two-wire sensor.

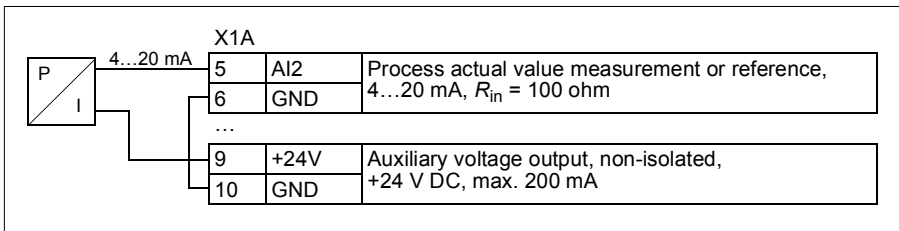

Note: The sensor is supplied through its current output. Thus the output signal must be 4...20 mA.



■ Default I/O connection diagram

The default connection of the control signals depends on the application macro in use, which is selected with parameter **9902 APPLIC MACRO**.

The default macro is the HVAC Default. It provides a general purpose I/O configuration with three constant speeds. Parameter values are the default values given in section **Parameters in the short parameter view** on page 146. For information on other macros, see section **Application macros** on page 81.

The default I/O connections for the ABB standard macro are given in the figure below.

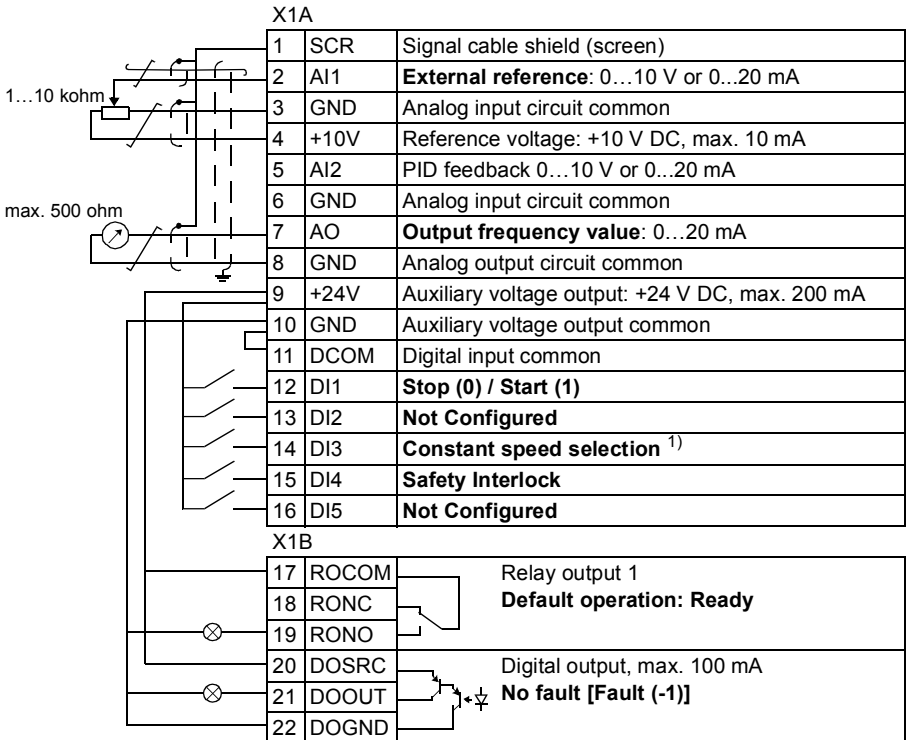

1) See parameter **Group 12: Constant speeds**: 2) 360 degree grounding under a clamp.

DI3	Operation (parameter)
0	Set speed through AI1
1	Speed 1 (1202)
0	Speed 2 (1203)
1	Speed 3 (1204)

Tightening torque: 0.4 N·m (3.5 lbf·in).

■ Connection procedure

1. Remove the terminal cover by simultaneously pushing the recess and sliding the cover off the frame.
2. *Digital signals:* Strip the outer insulation of the digital signal cable 360 degrees and ground the bare shield under the clamp.
3. Connect the conductors of the cable to the appropriate terminals. Use a tightening torque of 0.4 N·m (3.5 in-lb).
4. For double-shielded cables, twist also the grounding conductors of each pair in the cable together and connect the bundle to the SCR terminal (terminal 1).

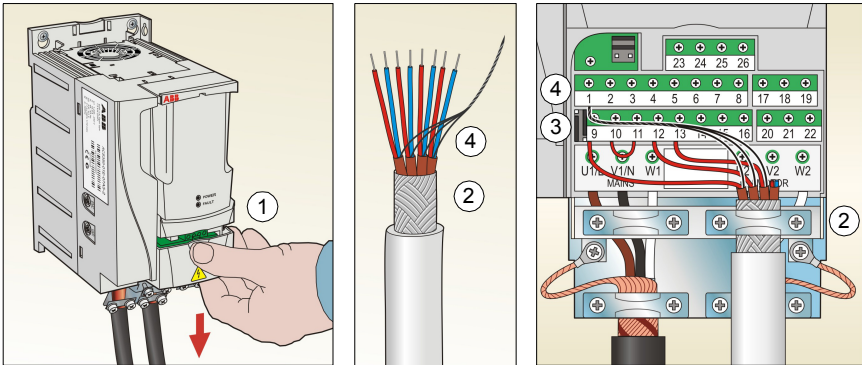

5. *Analog signals:* Strip the outer insulation of the analog signal cable 360 degrees and ground the bare shield under the clamp.
6. Connect the conductors to the appropriate terminals. Use a tightening torque of 0.4 N·m (3.5 in-lb).
7. Twist the grounding conductors of each pair in the analog signal cable together and connect the bundle to the SCR terminal (terminal 1).
8. Secure all cables outside the drive mechanically.
9. Slide the terminal cover back in place.

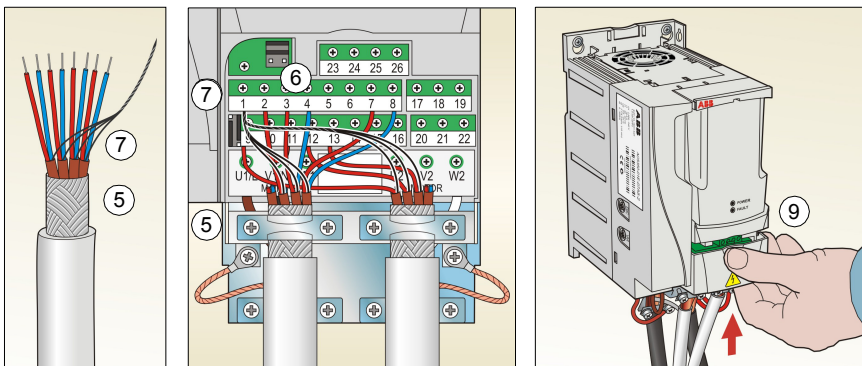

Connecting the embedded fieldbus

Embedded fieldbus can be connected to the drive with EIA-485 or RS-232.

■ Connection diagram

EIA-485

The figure below shows the fieldbus connection.

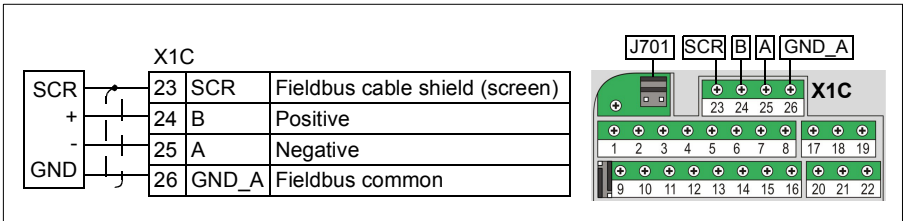

Terminate the EIA-485 bus with a 120 ohm resistor at the end of the network by setting the jumper J701 shunts as in the figure below.

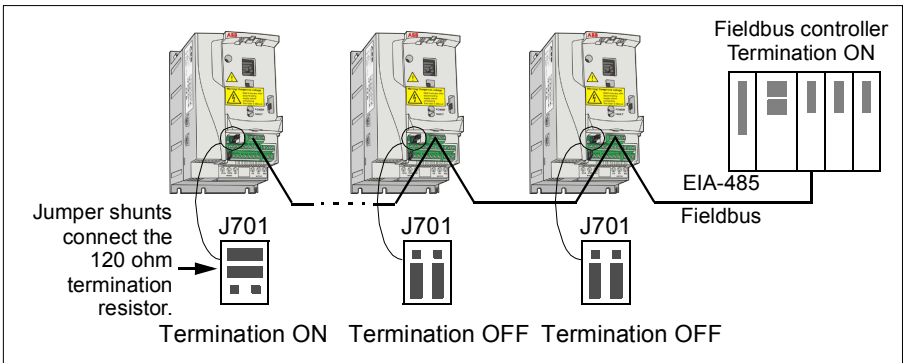

RS-232

Plug a communication cable into the control panel connection X2. The cable must be shorter than 3 meters.

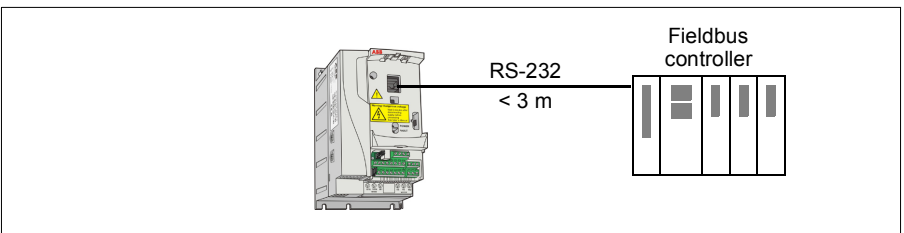



7

Installation checklist

Contents of this chapter

This chapter contains the task list to be followed after the mechanical and electrical installation before proceeding to starting up the drive.

Checking the installation

Check the mechanical and electrical installation of the drive before start-up. Go through the checklist below together with another person. Read chapter [Safety](#) on page [15](#) of this manual before you work on the drive.

Check	
MECHANICAL INSTALLATION	
<input type="checkbox"/>	The ambient operating conditions are allowed. (See Mechanical installation: Checking the installation site on page 29 as well as Technical data: Losses, cooling data and noise on page 395 and Ambient conditions on page 399 .)
<input type="checkbox"/>	The drive is fixed properly on an even vertical non-flammable wall. (See Mechanical installation on page 29 .)
<input type="checkbox"/>	The cooling air will flow freely. (See Mechanical installation: Free space around the drive on page 30 .)
<input type="checkbox"/>	The motor and the driven equipment are ready for start. (See Planning the electrical installation: Checking the compatibility of the motor and drive on page 36 as well as Technical data: Motor connection data on page 397 .)
ELECTRICAL INSTALLATION (See Planning the electrical installation on page 35 and Electrical installation on page 47 .)	
<input type="checkbox"/>	For ungrounded and corner grounded systems: The internal EMC filter is disconnected (EMC screw removed).
<input type="checkbox"/>	The capacitors are reformed if the drive has been stored over a year.
<input type="checkbox"/>	The drive is grounded properly.
<input type="checkbox"/>	The input power voltage matches the drive nominal input voltage.

Check	
<input type="checkbox"/>	The input power connections at U1, V1 and W1 are OK and tightened with the correct torque.
<input type="checkbox"/>	Appropriate input power fuses and disconnectors are installed.
<input type="checkbox"/>	The motor connections at U2, V2 and W2 are OK and tightened with the correct torque.
<input type="checkbox"/>	The motor cable, input power cable and control cables are routed separately.
<input type="checkbox"/>	Use wire ties to permanently affix control/communications wiring to the clamps provided to maintain a minimum 1/4" spacing from power wiring.
<input type="checkbox"/>	The external control (I/O) connections are OK.
<input type="checkbox"/>	The input power voltage cannot be applied to the output of the drive (with a bypass connection).
<input type="checkbox"/>	Terminal cover and, for NEMA 1, hood and connection box, are in place.

8

Start-up

Contents of this chapter

This chapter contains a brief description of the assistant (HVAC) control panel (operator keypad), start-up assistant and application selection.

This chapter also includes the application macros used for defining a group of parameters. Macros change a group of parameters to new, predefined values. Use macros to minimize the need for manual editing of parameters.

HVAC control panel features

The ACS320 HVAC control panel (ACH-CP-B) features:



1	Status LED (Green when normal, if flashing or red, see section LEDs on page 383.)
2	Soft key 1
3	Auto
4	Off
5	Up
6	Down
7	Soft key 2
8	Help (always available)
9	Hand





- Language selection for the display
- Drive connection that can be made or detached at any time
- Start-up assistant to facilitate drive commissioning
- Copy function for moving parameters to other ACS320 drives
- Backup function for saving parameter sets
- Context sensitive help
- Real-time clock

■ **General display features**

Soft key functions

The soft key functions are defined by text displayed just above each key.

Display contrast

To adjust display contrast, simultaneously press  and  or  , as appropriate.

Macros

Note: Selecting the appropriate macro should be part of the original system design, since the control wiring installed depends on the macro used.

1. Review the macro descriptions in section [Application macros](#) on page [81](#). Use the macro that best fits system needs.
2. Edit parameter [9902 APPLIC MACRO](#) to select the appropriate macro. Use either of the following:
 - Use the Start-up assistant, which displays the macro selection immediately after motor parameter setup.
 - Refer to section [Parameters mode](#) on page [68](#) for parameter editing instructions.

Turning - parameters



The system can benefit from one or more of the ACS320 special features, and/or fine tuning.

1. Review the parameter descriptions in section [Parameter listing](#) starting on page [150](#). Enable options and fine tune parameter values as appropriate for the system.
 2. Edit parameters as appropriate.
-

Fault and alarm adjustments

The drive can detect a wide variety of potential system problems. For example, initial system operation may generate faults or alarms that indicate set-up problems.

1. Faults and alarms are reported on the control panel with a number. Note the number reported.
2. Review the description provided for the reported fault/alarm:
 - Use the fault and alarm listings shown in chapter [Fault tracing](#) on 361.
 - Press the help key (Assistant control panel only) while fault or alarm is displayed.
3. Adjust the system or parameters as appropriate.



Start-up

Start-up can be performed in two ways:

- Using the Start-up assistant.

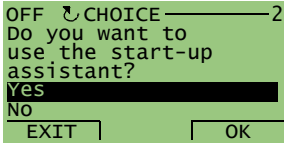







See section [Start-up by using the Start-up assistant](#).

- Changing the parameters individually.

See section [Start-up by changing the parameters individually](#).

■ Start-up by using the Start-up assistant











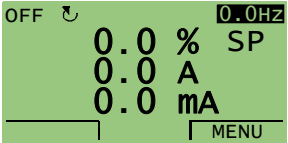

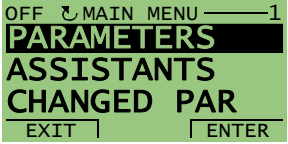
To start the Start-up assistant, follow these steps:

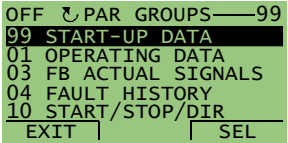
1	Select MENU to enter the main menu		<pre> OFF CHOICE-----2 0.0Hz 0.0 % SP 0.0 A 0.0 mA EXIT MENU </pre>
2	Select ASSISTANTS with the Up/Down buttons and select ENTER.	  	<pre> OFF CHOICE-----2 PARAMETERS ASSISTANTS CHANGED PAR EXIT ENTER </pre>
3	Scroll to Commission drive with the Up/Down buttons.	 	<pre> OFF CHOICE-----2 Spin the motor Commission drive References 1 & 2 Start/Stop Control Protections EXIT SEL </pre>
4	Change the values suggested by the assistant to your preferences and then press SAVE after every change.		<pre> OFF CHOICE----- 9901 LANGUAGE ENGLISH [0] EXIT SAVE </pre>

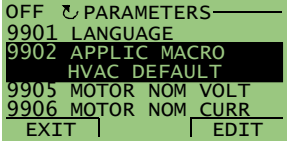
The Start-up assistant will guide you through the start-up.

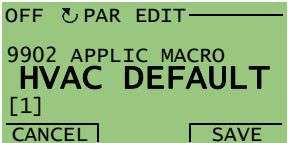
■ Start-up by changing the parameters individually

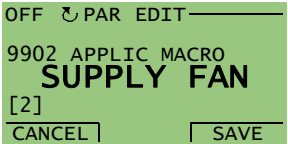
To change the parameters, follow these steps:

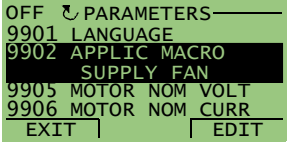
1	Select MENU to enter the main menu.		
2	Select PARAMETERS with the UP/DOWN buttons and select ENTER to select the Parameters mode.		
3	Select the appropriate parameter group with the UP/DOWN buttons and select SEL		
4	Select the appropriate parameter with the UP/DOWN buttons. Select EDIT to change the parameter value.		
5	Press the UP/DOWN buttons to change the parameter value.		
6	Select SAVE to store the modified value or select CANCEL to leave the set mode. Any modifications not saved are canceled.		
7	Select EXIT to return to the listing of parameter groups, and again to return to the main menu.	 	

To complete the control connections by manually entering the parameters, see section [Parameters mode](#) on page 68.

For detailed hardware description, see the chapter [Technical data](#).



Notes:

- The current parameter value appears below the highlighted parameter.
- To view the default parameter value, press the UP/DOWN buttons simultaneously.
- The most typical and necessary parameters to change belong to [Group 99: Start-up data](#), [Group 10: Start/Stop/Dir](#), [Group 11: Reference select](#), [Group 20: Limits](#), [Group 21: Start/Stop](#), [Group 22: Accel/Decel](#), [Group 30: Fault functions](#), [Group 53: EFB protocol](#) and [Group 98: Options](#).
- To restore the default factory settings, select the application macro HVAC default.

Modes

The HVAC control panel has several different modes for configuring, operating and diagnosing the drive. The modes are:

- **Standard display mode** – Shows drive status information and operates the drive.
- **Parameters mode** – Edits parameter values individually.
- **Start-up assistant mode** – Guides the start-up and configuration.
- **Changed parameters mode** – Shows changed parameters.
- **Fault logger mode** – Shows the drive fault history.
- **Drive parameter backup mode** – Stores or uploads the parameters.
- **Clock set mode** – Sets the time and date for the drive.
- **I/O settings mode** – Checks and edits the I/O settings.
- **Alarm mode** – Reporting mode triggered by drive alarms.

■ **Standard display mode**

Use the standard display mode to read information on the drive's status and to operate the drive. To reach the standard display mode, press EXIT until the LCD display shows status information as described below.



Status information

Top. The top line of the LCD display shows the basic status information of the drive.

- HAND – Indicates that the drive control is local, that is, from the control panel.
- AUTO – Indicates that the drive control is remote, such as the basic I/O (X1) or fieldbus.
- OFF – Indicates that the drive control is local and stopped.
- ↻ – Indicates the drive and motor rotation status as follows:

Control panel display	Significance
Rotating arrow (clockwise or counterclockwise)	<ul style="list-style-type: none"> • Drive is running and at setpoint • Shaft direction is forward or reverse
Rotating dotted arrow blinking	Drive is running but not at setpoint
Stationary dotted arrow	Start command is present, but motor is not running. For example, start enable is missing.

- Upper right – shows the active reference.

Middle. Using *Group 34: Panel display*, the middle of the LCD display can be configured to display:

- One to three parameter values – The default display shows parameters *0103 OUTPUT FREQ* in percentages, *0104 CURRENT* in amperes and *0120 A/I* in milliamperes.

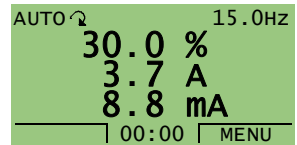

- Use parameters *3401*, *3408*, and *3415* to select the parameters (from *Group 01: Operating data*) to display. Entering “parameter” 0100 results in no parameter displayed. For example, if *3401* = 0100 and *3415* = 0100, then only the parameter specified by *3408* appears in the Control panel display.
- You can also scale each parameter in the display, for example, to convert the motor speed to a display of conveyor speed. Parameters *3402...3405* scale the parameter specified by *3401*, parameters *3409...3412* scale the parameter specified by *3408*, etc.

- A bar meter rather than one of the parameter values.
 - Enable bar graph displays using parameters *3404*, *3411* and *3418*.

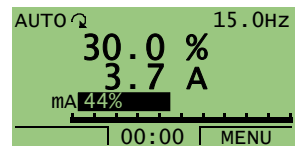



Bottom. The bottom of the LCD display shows:

- Lower corners – show the functions currently assigned to the two soft keys.
- Lower middle – displays the current time (if configured to show the time).

Operating the drive

AUTO/HAND – The very first time the drive is powered up, it is in the auto control (AUTO) mode, and is controlled from the Control terminal block X1.

To switch to hand control (HAND) and control the drive using the control panel, press and hold the  or  button.

- Pressing the HAND button switches the drive to hand control while keeping the drive running.
- Pressing the OFF button switches to hand control and stops the drive.

To switch back to auto control (AUTO), press and hold the  button.

Hand/Auto/Off – To start the drive press the HAND or AUTO buttons, to stop the drive press the OFF button.









Reference – To modify the reference (only possible if the display in the upper right corner is in reverse video) press the UP or DOWN buttons (the reference changes immediately).

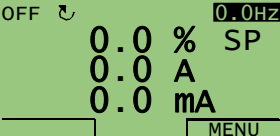



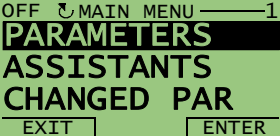

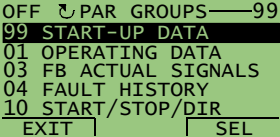

The reference can be modified in the local control mode, and can be parameterized (using [Group 11: Reference select](#)) to also allow modification in the remote control mode.

Note: The Start/Stop, Shaft direction and Reference functions are only valid in local control (LOC) mode.

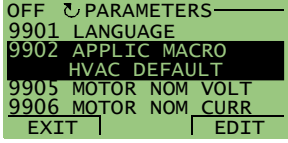
Parameters mode

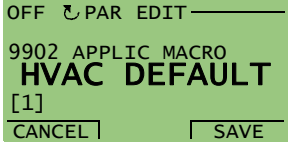
To change the parameters, follow these steps:

1	Select MENU to enter the main menu.		
2	Select PARAMETERS with the UP/DOWN buttons, and select ENTER to select the Parameters mode.	  	
3	Select the appropriate parameter group with the UP/DOWN buttons and select SEL.	  	

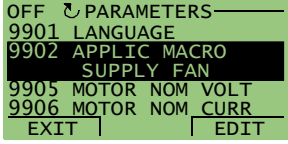
4	Select the appropriate parameter in a group with the UP/DOWN buttons. Select EDIT to change the parameter.	  	 <p>OFF ↻ PARAMETERS — 9901 LANGUAGE 9902 APPLIC MACRO HVAC DEFAULT 9905 MOTOR NOM VOLT 9906 MOTOR NOM CURR EXIT EDIT</p>
5	Press the UP/DOWN buttons to change the parameter value.	 	 <p>OFF ↻ PAR EDIT — 9902 APPLIC MACRO HVAC DEFAULT [1] CANCEL SAVE</p>
6	Select SAVE to store the modified value or select CANCEL to leave the set mode. <ul style="list-style-type: none"> Any modifications not saved are canceled. Each individual parameter setting is valid immediately after pressing SAVE. 		 <p>OFF ↻ PAR EDIT — 9902 APPLIC MACRO SUPPLY FAN [2] CANCEL SAVE</p>
7	Select EXIT to return to the listing of parameter groups, and again to return to the main menu.	 	 <p>OFF ↻ PARAMETERS — 9901 LANGUAGE 9902 APPLIC MACRO SUPPLY FAN 9905 MOTOR NOM VOLT 9906 MOTOR NOM CURR EXIT EDIT</p>

To complete the control connections by manually entering the parameters, see section [Parameters mode](#).

For detailed hardware description, see chapter [Dimension drawings](#).











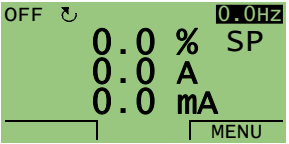

Notes:

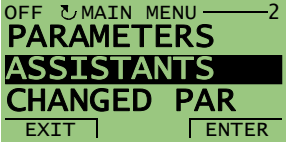
- The current parameter value appears below the highlighted parameter.
- To view the default parameter value, press the UP/DOWN buttons simultaneously.
- The most typical and necessary parameters to change belong to [Group 99: Start-up data](#), [Group 10: Start/Stop/Dir](#), [Group 11: Reference select](#), [Group 20: Limits](#), [Group 21: Start/Stop](#), [Group 22: Accel/Decel](#) and [Group 30: Fault functions](#).
- To restore the default factory settings, select the application macro HVAC default.

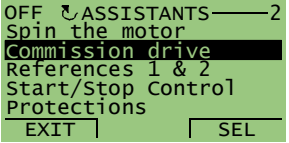

■ Start-up assistant mode

To start the Start-up assistant, follow these steps:

1	Select MENU to enter the main menu		
2	Select ASSISTANTS with the Up/Down buttons and select ENTER.	  	
3	Scroll to Commission drive with the Up/Down buttons and select SEL.	  	
4	Change the values suggested by the assistant to your preferences and then press SAVE after every change.	  	

The Start-up assistant will guide you through the start-up.

The Start-up assistant guides you through the basic programming of a new drive. (Familiarize yourself with basic control panel operation and follow the steps outlined above.) At the first start, the drive automatically suggests entering the first task, language select. The assistant also checks the values entered to prevent entries that are out of range.



The Start-up assistant is divided into tasks. You may activate the tasks one after the other, as the Start-up assistant suggests, or independently.

Note: If you want to set the parameters independently, use the Parameters mode.





The order of tasks presented by the Start-up assistant depends on your entries. The following task list is typical.

Task name	Description
Spin the motor	<ul style="list-style-type: none"> • Prompts for control panel display language selection. • Prompts for motor data. • Guides user through rotation check.
Commission drive	Prompts for motor data.
References 1 & 2	<ul style="list-style-type: none"> • Prompts for the source of speed references 1 and 2. • Prompts for reference limits. • Prompts for frequency (or speed) limits.
Start/Stop Control	<ul style="list-style-type: none"> • Prompts for the source for start and stop commands. • Prompts for start and stop mode definition. • Prompts for acceleration and deceleration times.
Protections	<ul style="list-style-type: none"> • Prompts for current and torque limits. • Prompts for the use of Run enable and Start enable signals. • Prompts for the use of emergency stop. • Prompts for Fault function selection. • Prompts for Auto reset functions selection.
Constant Speeds	<ul style="list-style-type: none"> • Prompts for the use of constant speeds. • Prompts for constant speed values.
PID control	<ul style="list-style-type: none"> • Prompts for PID settings. • Prompts for the source of process reference. • Prompts for reference limits. • Prompts for source, limits and units for the process actual value. • Defines the use of Sleep function.
PID flow	<ul style="list-style-type: none"> • Prompts for the use of flow calculation. • Prompts for units. • Prompts for maximum flow. • Prompts for transmitter signals.
Low Noise Set-up	<ul style="list-style-type: none"> • Prompts for switching frequency. • Prompts for definition of Flux optimization. • Prompts for the use of Critical speeds.
Panel Display	Prompts for display variable and unit settings.
Timed Functions	Prompts for the use of Timed functions.
Outputs	<ul style="list-style-type: none"> • Prompts for the signals indicated through the relay outputs. • Prompts for signals indicated through the analog output AO1. Sets the minimum, maximum, scaling and inversion values.
Serial Communication	<ul style="list-style-type: none"> • Prompts for communication settings. • Prompts for control access settings.

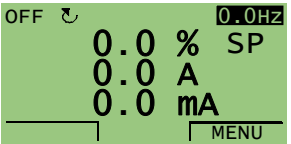

■ Changed parameters mode

To view (and edit) a listing of all parameters that have been changed from macro default values, follow these steps:

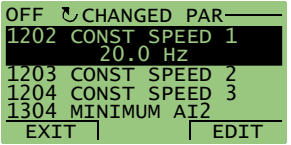
1	Select MENU to enter the menu.		
2	Select CHANGED PAR with the UP/DOWN buttons and select ENTER.		
3	A list of changed parameters is displayed. Select EXIT to exit the parameters mode.		

■ Fault logger mode

Use the Fault logger mode to see drive fault history, fault state details and help for the faults.

1. Select **FAULT LOGGER** in the MAIN MENU.
2. Press **ENTER** to see the latest faults (up to 10 faults, maximum).
3. Press **DETAIL** to see details for the selected fault.
 - Details are available for the three latest faults.
4. Press **DIAG** to see the help description for the fault. See chapter [Fault tracing](#).

Note: If a power off occurs, only the three latest faults will remain (with details only in the first fault).

■ Drive parameter backup mode

Use the parameter backup mode to export parameters from one drive to another. The parameters are uploaded from a drive to the control panel and downloaded from the control panel to another drive. Two options are available:











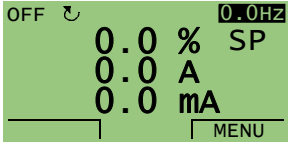

Par backup mode

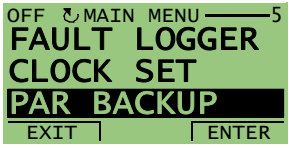
The Assistant control panel can store a full set of drive parameters.

The Par backup mode has these functions:

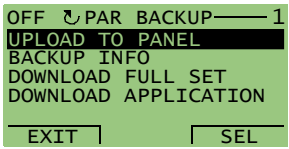

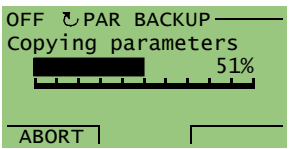

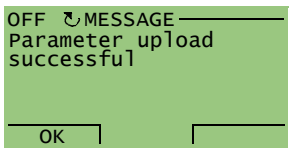
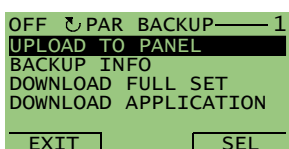



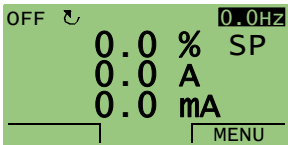

- UPLOAD TO PANEL** – Copies all parameters from the drive to the Control panel. This includes user sets of parameters (if defined) and internal parameters. The Control panel memory is non-volatile and does not depend on the panel's battery. To upload parameters to control panel, follow these steps:

1	Select MENU to enter the main menu.		
2	Select PAR BACKUP with the UP/DOWN buttons and select ENTER.	  	
3	Select UPLOAD TO PANEL and select SEL.	  	
4	The "Copying parameters" text and a progress diagram is displayed. Select ABORT if you want to stop the process.		
5	The "Parameter upload successful" text is displayed and the control panel returns to the PAR BACKUP menu. Select EXIT to return to the main menu. Now you can disconnect the panel.		 



- **DOWNLOAD FULL SET** – Restores the full parameter set from the Control panel to the drive. Use this option to restore a drive, or to configure identical drives. This download does not include user sets of parameters.

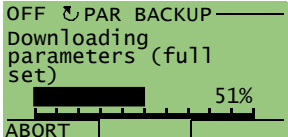

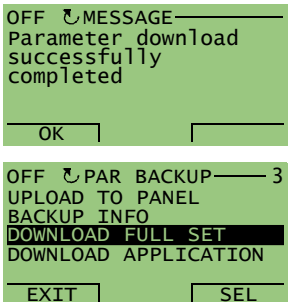



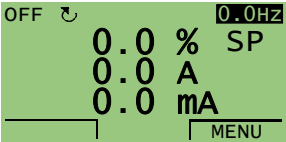

To download all parameters to drive, follow these steps:

1	Select MENU to enter the menu.		
2	Select PAR BACKUP with the UP/DOWN buttons.		
3	Scroll to DOWNLOAD FULL SET and select SEL.		
4	The "Downloading parameters" text is displayed. Select ABORT if you want to stop the process.		
5	After the download stops, the "Parameter download successfully completed" text is displayed and the control panel goes back to PAR BACKUP menu. Select EXIT to return to the main menu.		

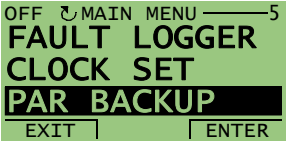
Note: Download full set writes all parameters to the drive, including motor parameters. Only use this function to restore a drive, or to transfer parameters to systems that are identical to the original system.

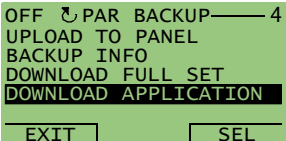
- Download application** – Copies a partial parameter set from the Control panel to a drive. The partial set does not include internal motor parameters, parameters 9905...9909, 1605, 1607, 5201, nor any *Group 53: EFB protocol* parameters. Use this option to transfer parameters to systems that use similar configurations – the drive and motor sizes do not need to be the same.

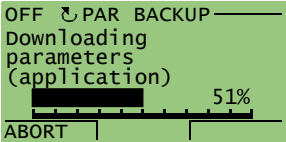
To download application to drive, follow these steps:

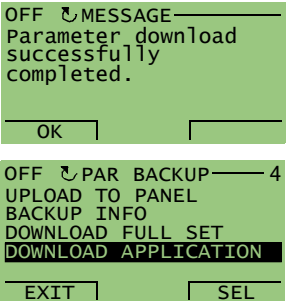
1	Select MENU to enter the menu.		
2	Select PAR BACKUP with the UP/DOWN buttons.		
3	Scroll to DOWNLOAD APPLICATION and select SEL.		
4	The "Downloading parameters" text is displayed. Select ABORT if you want to stop the process.		
5	The "Parameter download successfully completed" is displayed and the control panel returns to PAR BACKUP menu. Select EXIT to return to the main menu.		



Handling inexact downloads

In some situations, an exact copy of the download is not appropriate for the target drive. Some examples:

- A download to an old drive specifies parameters/values that are not available on the old drive.
- A download (from an old drive) to a new drive does not have definitions for the new parameters – parameters that did not originally exist.

As a default, the control panel handles these situations by:

- Discarding parameters/values not available on the target drive.
- Using parameter default values when the download provides no values or invalid values.
- Providing a Differences List – A listing of the type and number of items that the target cannot accept exactly as specified.

LOC  DIFFERENCES ----	
VALUES UNDER MIN	3
VALUES OVER MAX	2
INVALID VALUES	1
EXTRA PARS	5
MISSING VALUES	7
READY	SEL

You can either accept the default edits by pressing READY, or view and edit each item as follows:

1. Highlight an item type in the Differences List (left screen below) and press SEL to see the details for the selected type (right screen below).

LOC  DIFFERENCES ----	
VALUES UNDER MIN	3
VALUES OVER MAX	2
INVALID VALUES	1
EXTRA PARS	5
MISSING VALUES	7
READY	SEL

→

LOC  INVALID VAL	
9902 APLIC MACRO	
2606*SWITCHING FREQ	
12 kHz	
8 kHz	
3401*DISP 1 SEL	
EXIT	EDIT

In the above-right “details” screen:

- The first item that requires editing is automatically highlighted and includes details: In general, the first item listed in the details is the value defined by the backup file. The second item listed is the “default edit.”
 - For tracking purposes, an asterisk initially appears by each item. As edits are made, the asterisks disappear.
2. In the illustrated example, the backup specifies a switching frequency of 12 kHz, but the target drive is limited to 8 kHz.
 3. Press EDIT to edit the parameter. The display is the target drive’s standard edit screen for the selected parameter.

4. Highlight the desired value for the target drive.
5. Press SAVE to save setting.
6. Press EXIT to step back to the differences view and continue for each remaining exception.
7. When your editing is complete, press READY in the Differences List and then select “Yes, save parameters.”

Download failures

In some situations, the drive may be unable to accept a download. In those cases, the control panel display is: “Parameter download failed” plus one of the following causes:





- Set not found – You are attempting to download a data set that was not defined in the backup. The remedy is to manually define the set, or upload the set from a drive that has the desired set definitions.
- Par lock – The remedy is to unlock the parameter set (parameter [1602 PARAMETER LOCK](#)).
- Incompatible drive/model – The remedy is to perform backups only between drives of the same type and the same model.
- Too many differences – The remedy is to manually define a new set, or upload the set from a drive that more closely resembles the target drive.

Note: If upload or download of parameters is aborted, the partial parameter set is not implemented.



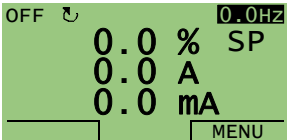









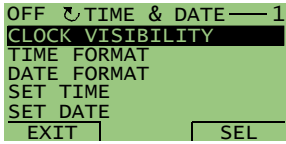



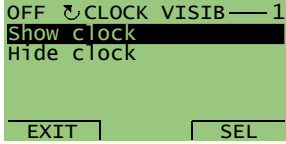



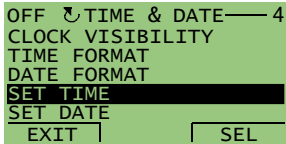



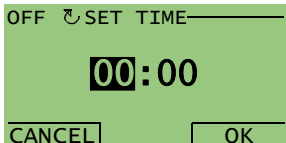

■ Clock set mode

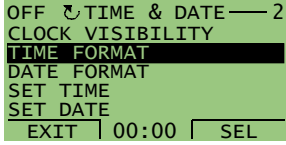
The clock set mode is used for setting the time and date for the internal clock of the drive. To use the timer functions of the drive, the internal clock has to be set first. Date is used to determine weekdays and is visible in Fault logs.



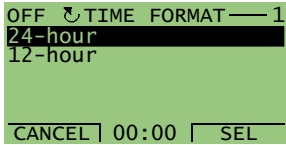



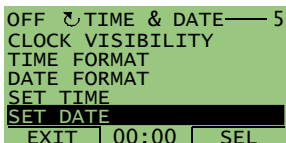



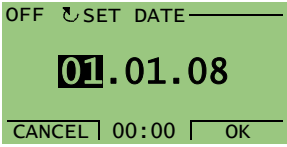

To set the clock, follow these steps:

1	Select MENU to enter the main menu.		
2	Scroll to CLOCK SET with the UP/DOWN buttons and select ENTER to enter the Time & date mode.	  	

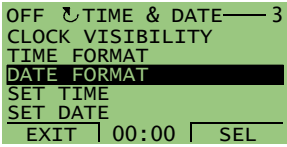

3	Select CLOCK VISIBILITY with the UP/DOWN buttons and select SEL to change the visibility of the clock.	  	
4	Scroll to Show clock with the UP/DOWN buttons and select SEL to make the clock visible.	  	
5	Scroll to SET TIME with the UP/DOWN buttons and select SEL.	  	
6	Change the hours and minutes with the UP/DOWN buttons and select OK to save the values. The active value is displayed in inverted color.	  	
7	Scroll to TIME FORMAT with the UP/DOWN buttons and select SEL.	  	
8	The different formats are displayed. Select a format with the UP/DOWN buttons and select SEL to confirm the selection.	  	
9	Scroll to SET DATE with the UP/DOWN buttons and select SEL.	  	

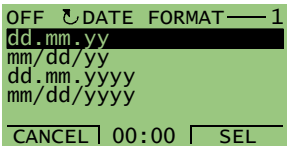

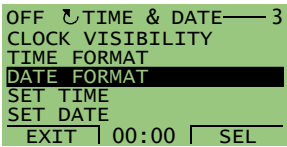







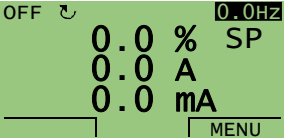







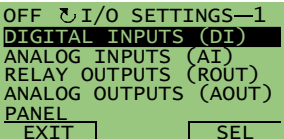

10	Change the days, months and year with the UP/DOWN buttons and select OK to save the values. The active value is displayed in inverted color.	  	
11	Scroll to DATE FORMAT with the UP/DOWN buttons and select SEL.	  	
12	The DATE FORMATS are displayed. Select a date format with the UP/DOWN buttons and select OK to confirm the selection.	  	
13	Select EXIT twice to return to the main menu.		

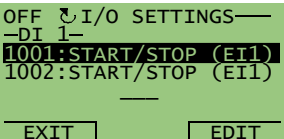

I/O settings mode

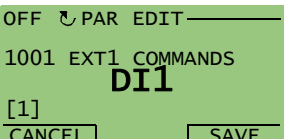
To view and edit the I/O settings, follow these steps:

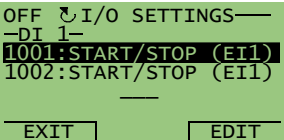
1	Select MENU to enter the main menu.		
2	Scroll to I/O SETTINGS with the UP/DOWN buttons and select ENTER.	  	
3	Scroll to the I/O setting you want to view with the UP/DOWN buttons and select SEL.	  	
4	Select the setting you want to view with the UP/DOWN buttons and select EDIT.	  	
5	You can change the value with the UP/DOWN buttons and save it by selecting SAVE. If you do not want to change the setting, select CANCEL.	   	
6	Select EXIT to return to the main menu.		



9

Application macros

Contents of this chapter

This chapter describes the application macros. For each macro, there is a wiring diagram showing the default control connections (digital and analog I/O). The chapter also explains how to save a user macro and how to recall it.

Overview of macros

Application macros are pre-programmed parameter sets. Macros change a group of parameters to new, predefined values designed for specific applications. Use macros to minimize the need for manual editing of parameters. Selecting a macro sets all other parameters to their default values, except:

- *Group 99: Start-up data*
- *1602 PARAMETER LOCK*
- *1607 PARAM. SAVE*
- *3018 COMM FAULT FUNC* and *3019 COMM FAULT TIME*
- *9802 COMM PROT SEL*
- *Group 52: Panel comm* and *Group 53: EFB protocol*
- *Group 29: Maintenance trig.*

After selecting a macro, additional parameter changes can be made manually using the control panel.

Application macros are enabled by setting the value for parameter *9902 APPLIC MACRO*. By default, HVAC default (value 1) is the enabled macro.



General considerations

The following considerations apply for all macros:





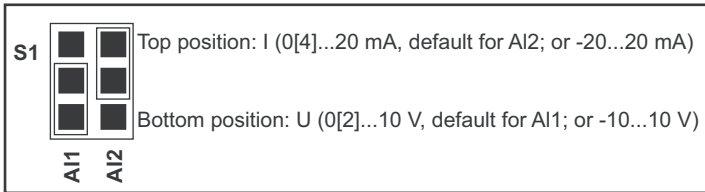





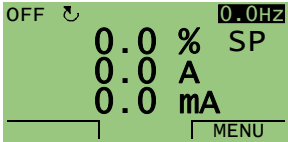

- When using a direct speed reference in AUTO mode, connect the speed reference to analog input 1 (AI1), and provide the START command using digital input 1 (DI1). In HAND/OFF mode, the control panel provides the speed reference and START command.
- When using process PID, connect the feedback signal to analog input 2 (AI2). As a default, the control panel sets the Setpoint, but analog input 1 can be used as an alternate source. You can set up process PID using parameters (Group 40) or using the PID control assistant (recommended).

The S1 Jumpers are set for AI1 External Reference and PID Feedback as either 20 mA or 10 V.

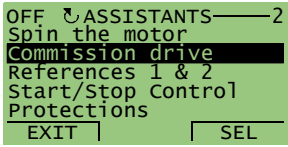

Selecting an application macro

To select a macro, follow these steps:

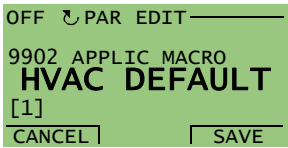
1	Select MENU to enter the main menu.		
2	Select ASSISTANTS with the Up/Down buttons and select ENTER.	  	
3	Scroll to Commission drive and select ENTER.	  	
4	Select a macro with the Up/Down buttons and select SAVE.	  	

Restoring defaults

To restore the factory default settings, select application macro HVAC default.

Control wiring

Each macro has specific requirements for control wiring. Specific wiring requirements are included with each macro description.



Application / Macro listing

This section describes the following macros:

9902 value	Macro		9902 value	Macro
1	HVAC DEFAULT (page 85)		9	INT TIMER CS (page 93)
2	SUPPLY FAN (page 86)		10	FLOATING PNT (page 94)
3	RETURN FAN (page 87)		11	DUAL SETPPID (page 95)
4	CLNG TWR FAN (page 88)		12	DUAL SP PID WITH CS (page 96)
5	CONDENSER (page 89)		13	E-BYPASS (page 97)
6	BOOSTER PUMP (page 90)		14	HAND CONTROL (page 98)
7	PUMP ALTERNA (page 91)		15	E-CLIPSE (page 99)
8	INT TIMER (page 92)		21	AC500 MODBUS (page 100)



■ HVAC default

This macro provides the factory default parameter settings for the drive. Factory defaults can be restored at any time by setting parameter **9902 APPLIC MACRO** to 1. The diagram below shows typical wiring using this macro. When using direct speed reference in AUTO mode or process PID, see section **General considerations** on page 82.

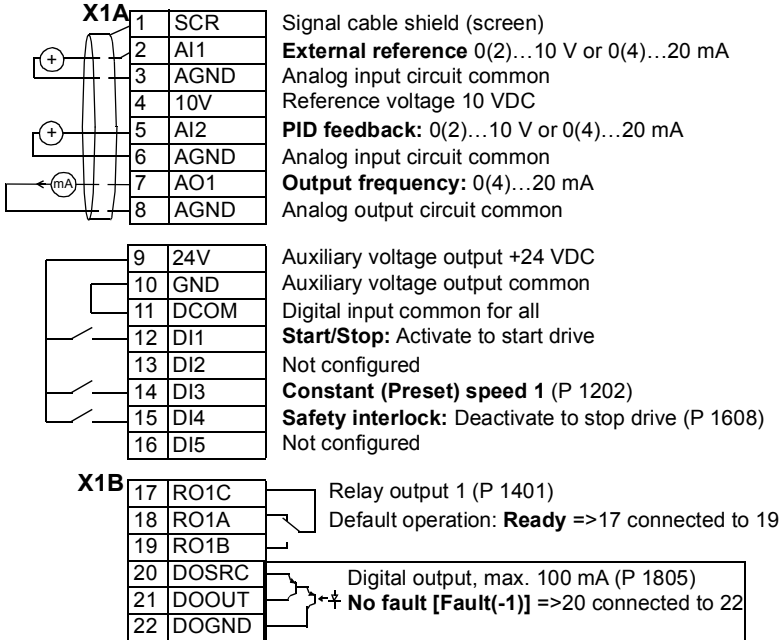

Supply fan

This macro configures for supply fan applications where the supply fan brings fresh air in according to signals received from a transducer. When using direct speed reference in AUTO mode or process PID, see [General considerations](#) on page 82.

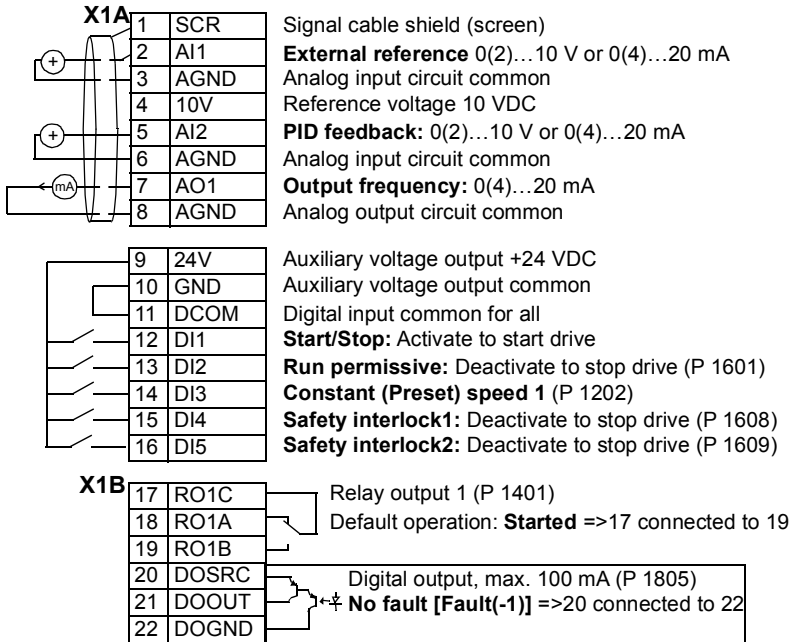

Parameters changed relative to HVAC default		
Parameter		Value
9902	APPLIC MACRO	2 (SUPPLYFAN)
1401	RELAY OUTPUT 1	7 (STARTED)
1601	RUN ENABLE	2 (DI2)
1609	START ENABLE 2	5 (DI5)

For more information see [Default values with different macros](#) on page 281.

Return fan

This macro configures for return fan applications where the return fan removes air according to signals received from a transducer. When using direct speed reference in AUTO mode or process PID, see [General considerations](#) on page 82.

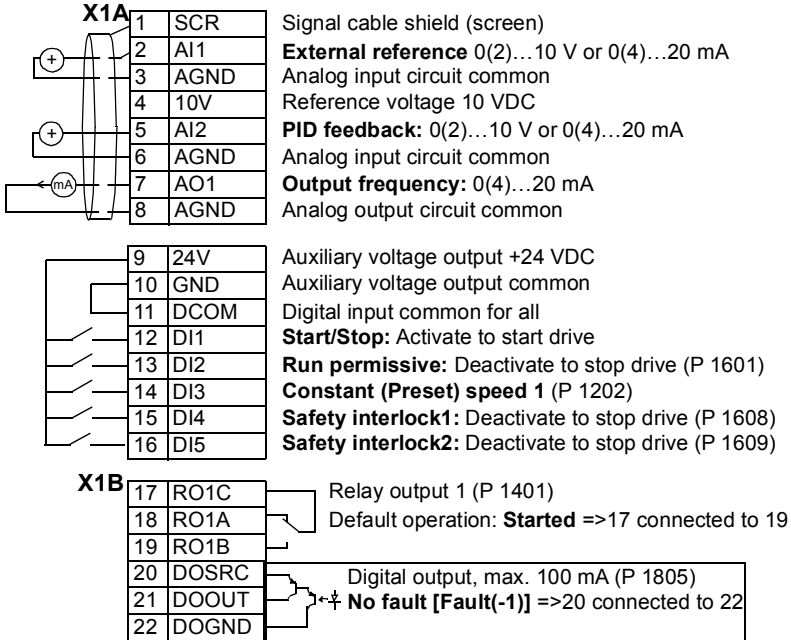

Parameters changed relative to HVAC default		
Parameter		Value
9902	APPLIC MACRO	3 (RETURNFAN)
1401	RELAY OUTPUT 1	7 (STARTED)
1609	START ENABLE 2	5 (DI5)

For more information see [Default values with different macros](#) on page 281.



Cooling tower fan

This macro configures for cooling tower fan applications where the fan speed is controlled according to the signals received from a transducer. When using direct speed reference in AUTO mode or process PID, see [General considerations](#) on page 82.

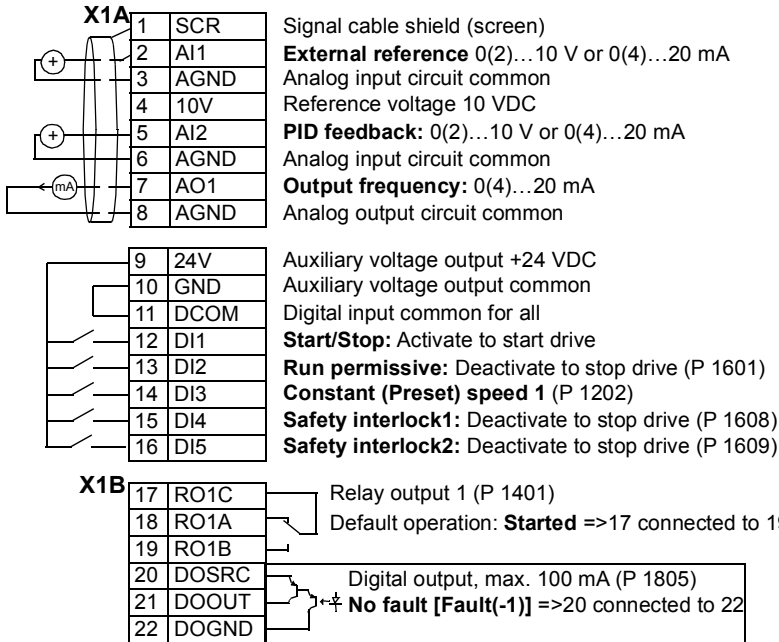

Parameters changed relative to HVAC default

Parameter	Value
9902 APPLIC MACRO	4 (CLNGTWRFAN)
2007 MINIMUM FREQ	20.0 HZ
4005 ERROR VALUE INV	1 (YES)

For more information see [Default values with different macros](#) on page 281.

Condenser

This macro configures for condenser and liquid cooler applications where fan speed is controlled according to signals received from a transducer. When using direct speed reference in AUTO mode or process PID, see [General considerations](#) on page 82.

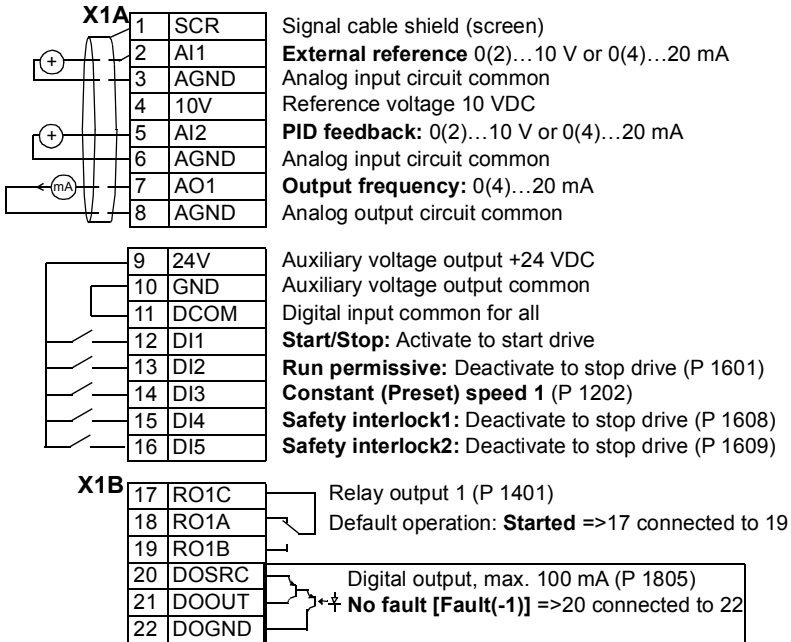

Parameters changed relative to HVAC default		
Parameter		Value
9902	APPLIC MACRO	5 (CONDENSER)
4005	ERROR VALUE INV	1 (YES)



For more information see [Default values with different macros](#) on page 281.

Booster pump

This macro configures for booster pump applications where the pump speed is controlled according to a signal received from a transducer. When using direct speed reference in AUTO mode or process PID, see [General considerations](#) on page 82.

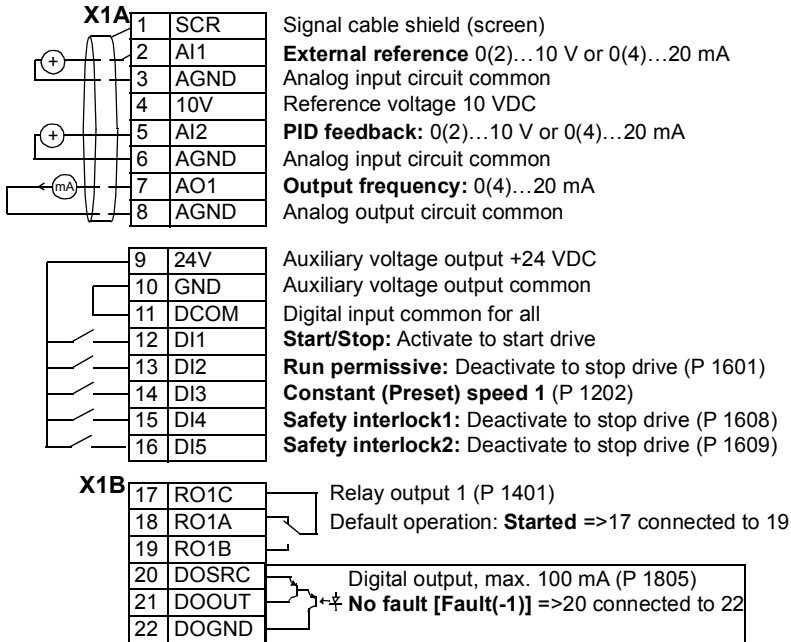

Parameters changed relative to HVAC default

Parameter	Value
9902 APPLIC MACRO	6 (BOOSTER PUMP)
2101 START FUNCTION	1 (AUTO)
2202 ACCELER TIME 1	10.0 s
2203 DECELER TIME 1	10.0 s

For more information see [Default values with different macros](#) on page 281.

■ PFA control macro

This macro provides parameter settings for pump and fan alternation (PFA) applications. To enable the macro, set the value of parameter **9902 APPLIC MACRO** to 7 (PUMP ALTERNA).

Note: Parameter **2108 START INHIBIT** must remain in the default setting 0 (OFF).

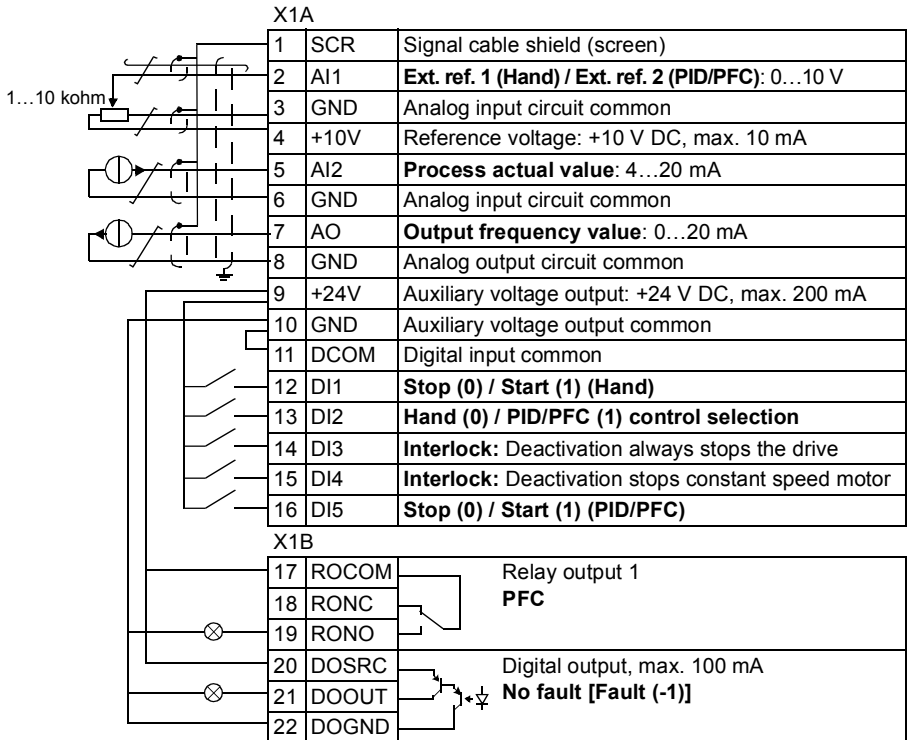

Parameters changed relative to HVAC default			
Parameter	Value	Parameter	Value
9902 APPLIC MACRO	7 (PUMP ALTERNA)	2203 DECELER TIME 1	10.0 s
1201 CONST SPEED SEL	0 (NOT SEL)	8109 START FREQ 1	58.0 Hz
1401 RELAY OUTPUT 1	31 (PFA)	8110 START FREQ 2	58.0 Hz
1608 START ENABLE 1	0 (NOT SEL)	8111 START FREQ 3	58.0 Hz
2101 START FUNCTION	1 (AUTO)	8120 INTERLOCKS	
2202 ACCELER TIME 1	10.0 s	8123 PFA ENABLE	1 (ACTIVE)



Internal timer

This macro configures for applications where a built-in timer starts and stops the motor. When the variable speed pump reaches a maximum speed limit, auxiliary pumps start as needed. When using direct speed reference in AUTO mode or process PID, see section [General considerations](#) on page 82.

Momentarily activating digital input 3 (DI3) provides a boost function which operates the motor. See [Group 36: Timed functions](#) for more information on setting up timers.

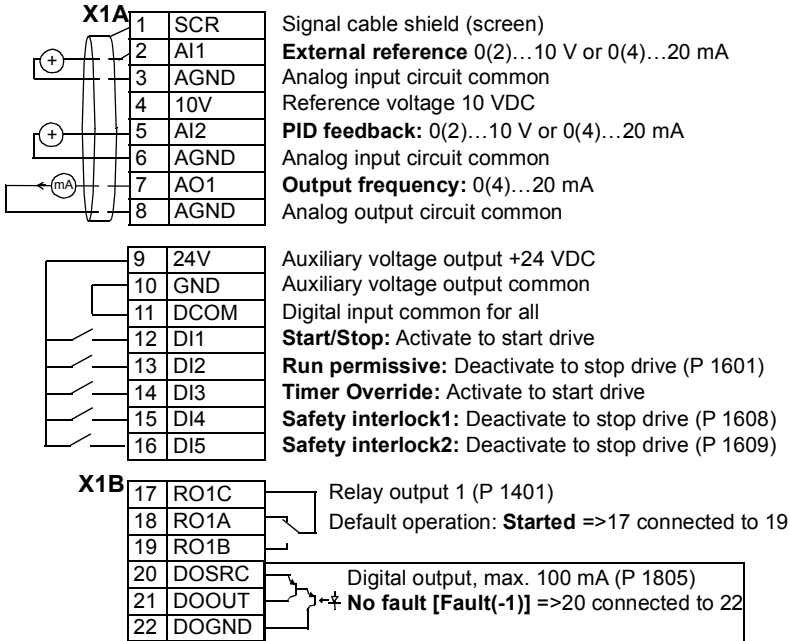

Parameters changed relative to HVAC default

Parameter	Value	Parameter	Value
9902 APPLIC MACRO	8 (INT TIMER)	1609 START ENABLE 2	5 (DI5)
1001 EXT1 COMMANDS	11 (TIMER1)	3207 SUPERV 3 PARAM	0103 (OUTPUT FREQ)
1002 EXT2 COMMANDS	11 (TIMER1)	3601 TIMERS ENABLE	1 (DI1)
1201 CONST SPEED SEL	0 (NOT SEL)	3622 BOOST SEL	3 (DI3)
1401 RELAY OUTPUT 1	7 (STARTED)	3626 TIMER 1 SRC	31 (P1+2+3+4+B)
1601 RUN ENABLE	2 (DI2)		

For more information see [Default values with different macros](#) on page 281.

Internal timer with constant speeds / PRV

This macro configures for applications such as a timed powered roof ventilator (PRV) which alternates between two constant speeds (constant speed 1 and 2) based on a built-in timer.

Momentarily activating digital input 3 (DI3) provides a boost function which operates the motor. See [Group 36: Timed functions](#) for more information on setting up timers.

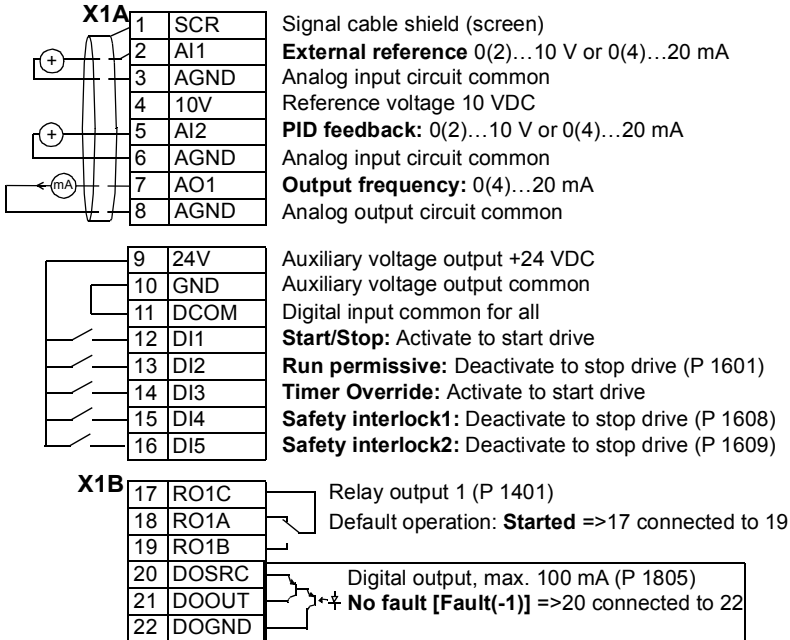

Parameters changed relative to HVAC default					
Parameter		Value	Parameter		Value
9902	APPLIC MACRO	9 (INT TIMER CS)	3419	OUTPUT3 UNIT	4 (%)
1002	EXT2 COMMANDS	0 (NOT SEL)	3420	OUTPUT3 MIN	-200.0%
1103	REF1 SEL	0 (KEYPAD)	3421	OUTPUT3 MAX	200.0%
1201	CONST SPEED SEL	15 (TIMER1)	3501	TIMERS ENABLE	1 (DI1)
1401	RELAY OUTPUT 1	7 (STARTED)	3622	BOOST SEL	3 (DI3)
1601	RUN ENABLE	2 (DI2)	3626	TIMER 1 SRC	31 (P1+2+3+4+B)
1609	START ENABLE 2	5 (DI5)	4010	SET POINT SEL	1 (AI1)
3415	SIGNAL 3 PARAM	0105 (TORQUE)	4110	SET POINT SEL	1 (AI1)
3418	OUTPUT 3 DSP FORM	1 (+/-0.0)			

For more information see [Default values with different macros](#) on page 281.



Floating point

This application macro is for applications where speed reference needs to be controlled through digital inputs (DI4 & DI5). By activating digital input 4, the speed reference increases, by activating digital input 5, the speed reference decreases. If both digital inputs are active or inactive, the reference does not change.

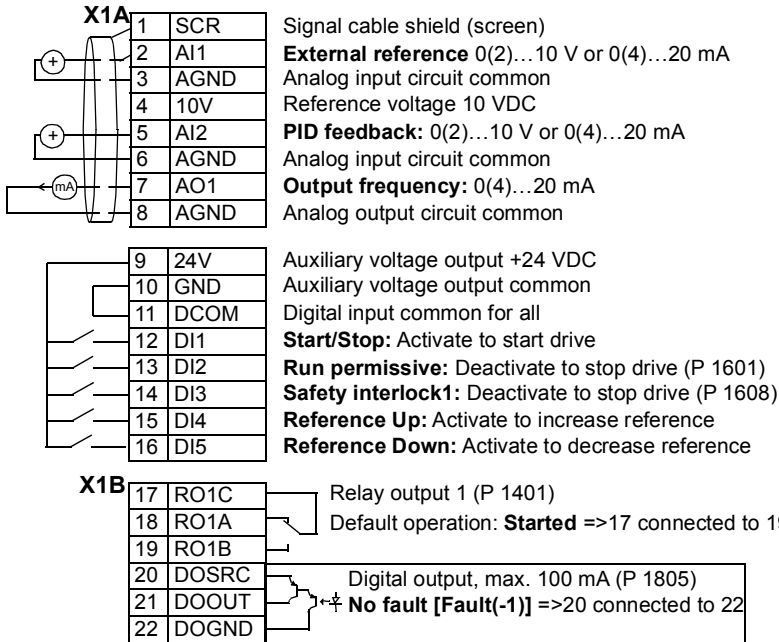

Parameters changed relative to HVAC default

Parameter	Value	Parameter	Value
9902 APPLIC MACRO	10 (FLOATINGPNT)	3416 SIGNAL3 MIN	
1103 REF1 SEL	30 (DI4U, 5D)	3418 OUTPUT3 DSP FORM	1 (+/-0.0)
1401 RELAY OUTPUT 1	7 (STARTED)	3419 OUTPUT3 UNIT	0 (%)
1601 RUN ENABLE	2 (DI2)	3420 OUTPUT3 MIN	-200.0%
3415 SIGNAL3 PARAM	0105 (TORQUE)	3421 OUTPUT3 MAX	200.0%

For more information see [Default values with different macros](#) on page 281.



Dual setpoint with PID

This macro configures for dual setpoint PID applications, where activating digital input 3 (DI3) changes the process PID controller's setpoint to another value. When using direct speed reference in AUTO mode or process PID, see section [General considerations](#) on page 82. Set process PID setpoints (internal to the drive) using parameters 4011 (SET1) and 4111 (SET2).

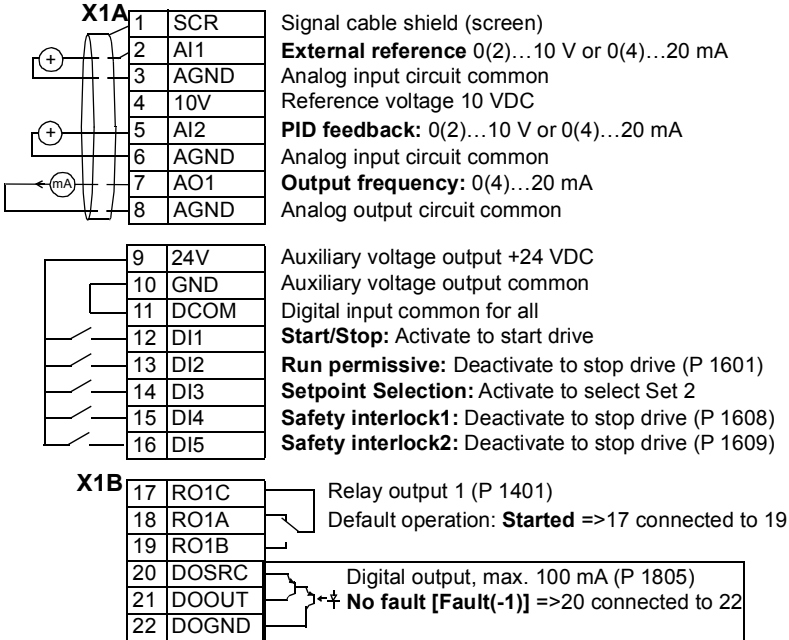

Parameters changed relative to HVAC default					
Parameter	Value	Parameter	Value		
9902	APPLIC MACRO	11 (DUAL SETPNT)	4010	SETPOINT SEL	19 (INTERNAL)
1201	CONST SPEED SEL	0 (NOT SEL)	4011	INTERNAL SETPNT	50.0%
1401	RELAY OUTPUT 1	7 (STARTED)	4027	PID 1 PARAM SET	3 (DI3)
1601	RUN ENABLE	2 (DI2)	4110	SETPOINT SEL	19 (INTERNAL)
1609	START ENABLE 2	5 (DI5)	4111	INTERNAL SETPNT	100.0%



Dual setpoint with PID and constant speeds

This macro configures for applications with 2 constant speeds, active PID and PID alternating between two setpoints using digital inputs. Set PID setpoints (internal to the drive) using parameters 4011 (SET1) and 4111 (SET2). The digital input DI3 selects the setpoints.

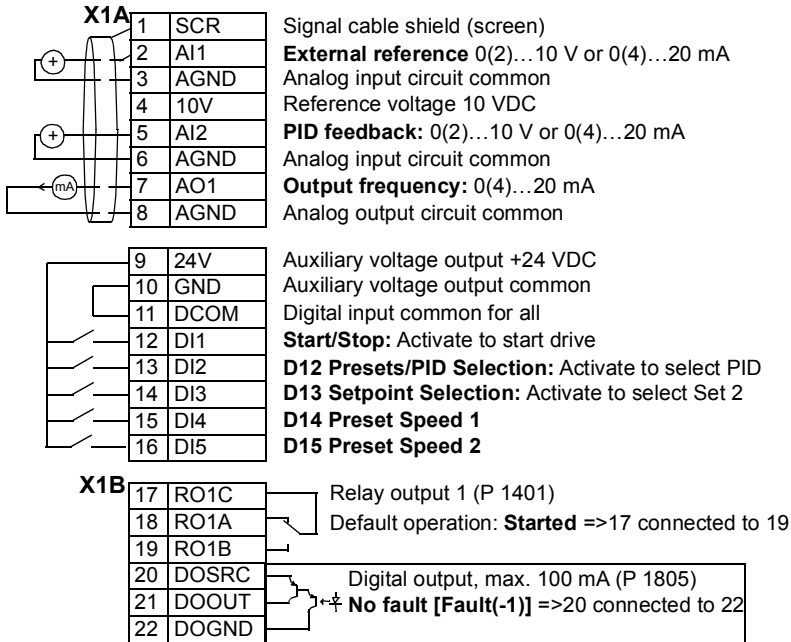

Parameters changed relative to HVAC default					
Parameter		Value	Parameter		Value
9902	APPLIC MACRO	12 (DL SP PID CS)	4011	INTERNAL SETPNT	50.0%
1201	CONST SPEED SEL	10 (DI4, 5)	4027	PID 1 PARAM SET	3 (DI3)
1608	START ENABLE 1	0 (NOT SEL)	4110	SETPOINT SEL	19 (INTERNAL)
2108	START INHIBIT	1 (ON)	4111	INTERNAL SETPNT	100.0%
4010	SET POINT SEL	19 (INTERNAL)			

For more information see [Default values with different macros](#) on page 281.



E-BYPASS

This macro configures for an E-Bypass device which can bypass the drive and connect the motor direct on-line. When using direct speed reference in AUTO mode or process PID, see section [General considerations](#) on page 82.

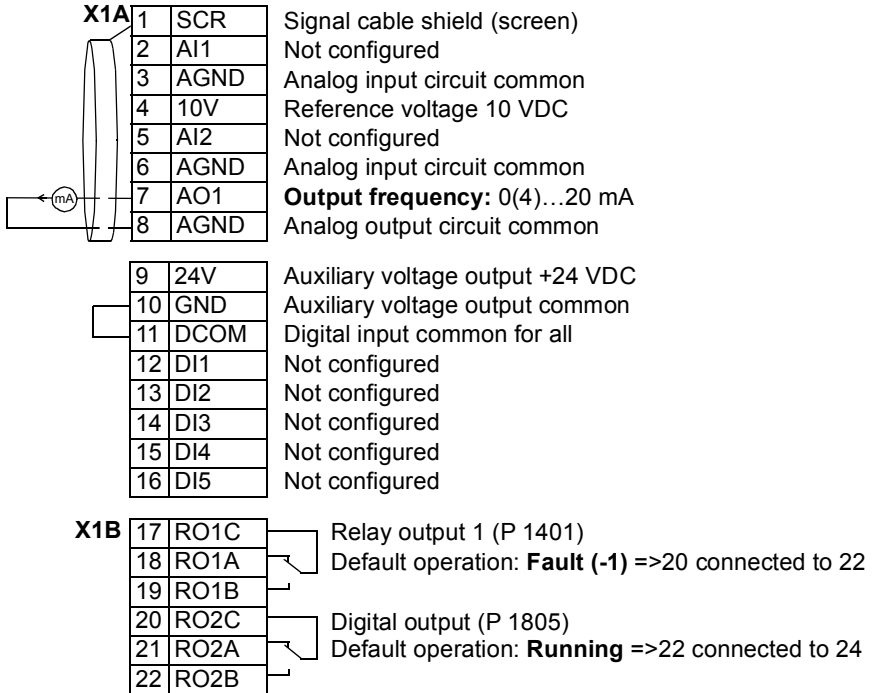

Parameters changed relative to HVAC default		
Parameter		Value
9902	APPLIC MACRO	13 (E-BYPASS)
1201	CONST SPEED SEL	0 (NOT SEL)
1401	RELAY OUTPUT 1	7 (STARTED)
1601	RUN ENABLE	2 (DI2)
1608	START ENABLE 1	0 (NOT SEL)

For more information see [Default values with different macros](#) on page 281.



■ Hand control

This macro configures for drive control using only the control panel with no automated control. Typically, this is a temporary configuration used prior to control wiring.

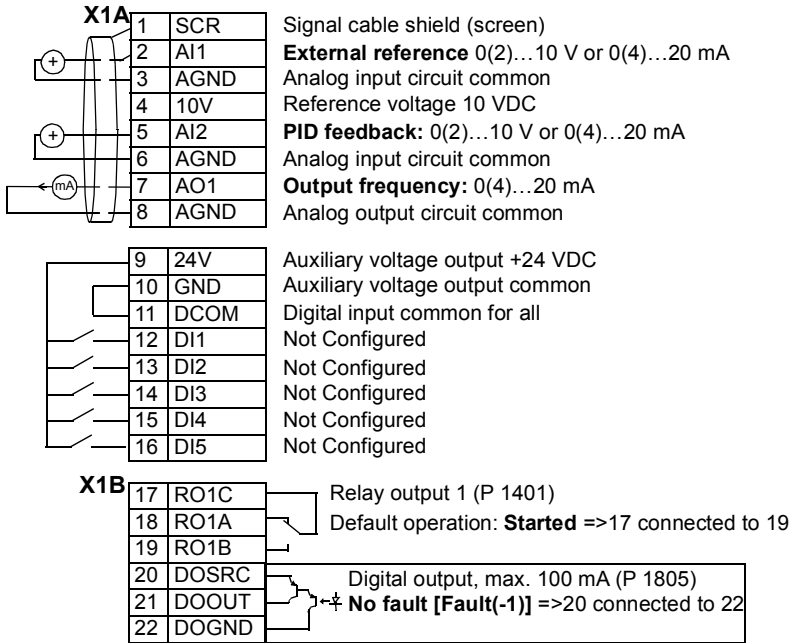

Parameters changed relative to HVAC default

Parameter	Value	Parameter	Value
9902 APPLIC MACRO	14 (HAND CONTROL)	3415 SIGNAL3 PARAM	100 (NOT SEL)
1001 EXT1 COMMANDS	0 (NOT SEL)	3416 SIGNAL3 MIN	(-)
1002 EXT2 COMMANDS	0 (NOT SEL)	3417 SIGNAL3 MAX	(-)
1106 REF3 SEL	2 (AI2)	3418 OUTPUT 3 DSP FORM	(-)
1201 CONST SPEED SEL	0 (NOT SEL)	3419 OUTPUT 3 DSP UNIT	(-)
1301 MINIMUM AI1	0.0%	3420 OUTPUT 3 MIN	(-)
1304 MINIMUM AI2	0.0%	3421 OUTPUT 3 MAX	(-)
1401 RELAY OUTPUT 1	7 (STARTED)	4001 GAIN	1.0
1504 MINIMUM AO1	0.0mA	4002 INTEGRATION TIME	60.0 s
1510 MINIMUM AO2	0.0mA	4010 SETPOINT SEL	1 (AI1)
1601 RUN ENABLE	2 (DI2)	4101 GAIN	1.0
1608 START ENABLE 1	0 (NOT SEL)	4102 INTEGRATION TIME	60.0 s
2108 START INHIBIT	1 (ON)	4110 SETPOINT SEL	1 (AI1)
3207 SUPERV 3 PARAM	0103 (OUTPUT FREQ)	4210 SETPOINT SEL	1 (AI1)



E-Cclipse

This macro configures an E-Cclipse Bypass device which can bypass the drive and connect the motor direct on-line. When using direct speed reference in AUTO mode or process PID, see section [General considerations](#) on page 82.

Note: This macro is available only for the UK version.

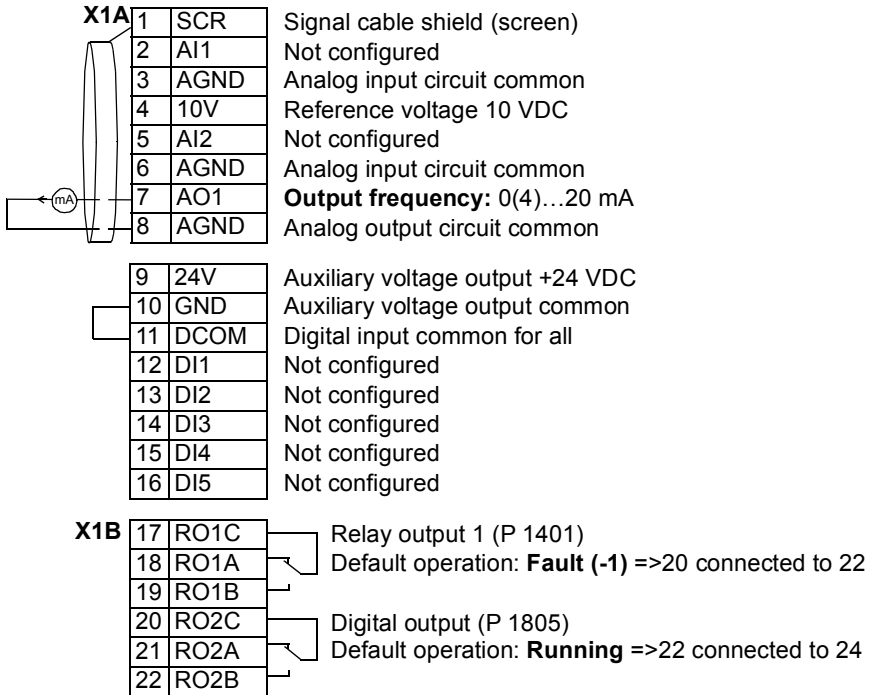

Parameters changed relative to HVAC default					
Parameter		Value	Parameter		Value
9902	APPLIC MACRO	15 (E-CLIPSE)	1608	START ENABLE 1	7 (COMM)
9802	COMM PROTO SEL	1 (STD MODBUS)	5303	EFB BAUD RATE	76.8 kb/s
1001	EXT1 COMMANDS	10 (COMM)	5304	EFB PARITY	2 (8 EVEN 1)
1002	EXT2 COMMANDS	10 (COMM)	5305	EFB CTRL PROFILE	1 (DCU PROFILE)
1601	RUN ENABLE	7 (COMM)			

For more information see [Default values with different macros](#) on page 281.



■ Modbus configuration macro

This macro configures the drive communication and control parameters. The macro is available in ACS320 drives with firmware version 4.03c or later.

To enable the macro, set the value of parameter **9902 APPLIC MACRO** to 21 (AC500 MODBUS).

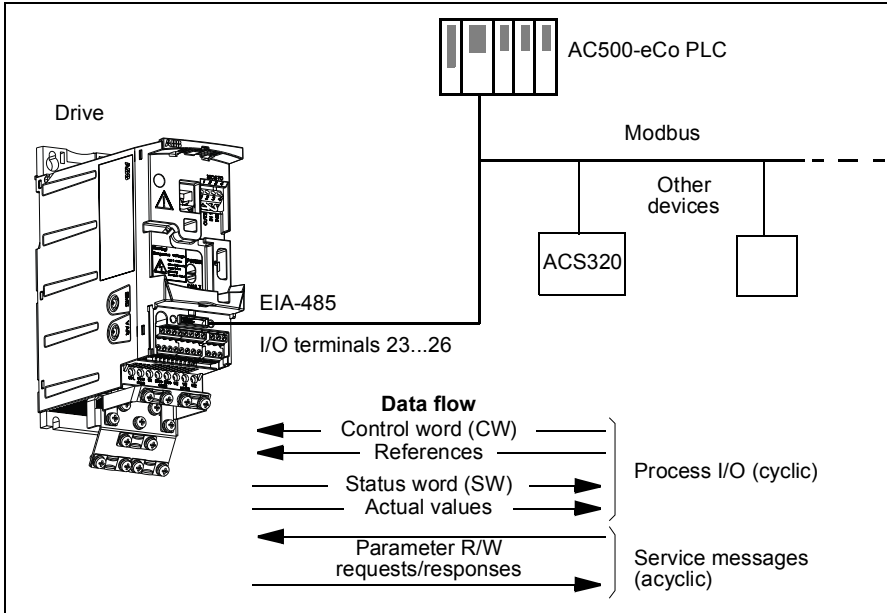

The AC500 MODBUS application macro default values for the drive parameters correspond to the ABB standard macro (parameter **9902**, value 1 (HVAC DEFAULT), see section **HVAC default** on page 85), with the following differences:

Parameters changed relative to HVAC default			
Parameter	Value	Parameter	Value
9902 APPLIC MACRO	21 (AC500 MODBUS)	5302 EFB STATION ID	2
1001 EXT1 COMMANDS	10 (COMM)	5303 EFB BAUD RATE	192 (19.2 kbits/s)
1102 EXT1/EXT2 SEL	8 (COMM)	5304 EFB PARITY	0 (8 NONE 1)
1103 REF1 SELECT	8 (COMM)	5305 EFB CTRL PROFILE	2 (ABB DRV FULL)
1604 FAULT RESET SEL	8 (COMM)	5310 EFB PAR10	101
2201 ACC/DEC 1/3 SEL	0 (NOT SEL)	5311 EFB PAR11	303
3028 COMM FAULT FUNC	1 (FAULT)	5312 EFB PAR12	305
9802 COMM PROT SEL	1 (STD MODBUS)		

Note: The default slave address of the drive is 2 (parameter **5303 EFB STATION ID**), but if several drives are used, the address must be unique for each drive.



Program features

Contents of this chapter

The chapter describes program features. For each feature, there is a list of related user settings, actual signals, and fault and alarm messages.

Start-up assistant

■ Introduction

The Start-up assistant (requires the Assistant control panel) guides the user through the start-up procedure, helping to enter the requested data (parameter values) to the drive. The Start-up assistant also checks that the entered values are valid, in other words, within the allowed range.

The Start-up assistant calls other assistants, each of which guides the user through the task of specifying a related parameter set. At the first start, the drive suggests entering the first task, Language select, automatically. The user may activate the tasks either one after the other as the Start-up assistant suggests, or independently. The user may also adjust the drive parameters in the conventional way without using the assistant at all.

■ List of the tasks and the relevant drive parameters

Depending on the selection made in the Application task (parameter [9902 APPLIC MACRO](#)), the Start-up assistant decides which consequent tasks it suggests.

Name	Description	Set parameters
Language select	Selecting the language	9901
Motor set-up	Setting the motor data	9905...9909
Application	Selecting the application macro	9902 , parameters associated to the macro
Option modules	Activating the option modules	Group 35: Motor temp meas , Group 52: Panel comm , 9802
Speed control EXT1	Selecting the source for the speed (output frequency) reference (If AI1 is used: Setting analog input AI1 limits, scale, inversion) Setting the reference limits Setting the frequency limits Setting the acceleration and deceleration times	1103 (1301...1303, 3001) 1104, 1105 2007, 2008 2202, 2203
Speed control EXT2	Selecting the source for the speed (output frequency) reference (If AI1 is used: Setting analog input AI1 limits, scale, inversion) Setting the reference limits	1106 (1301...1303, 3001) 1107, 1108
PID control	Selecting the source for the process reference (If AI1 is used: Setting analog input AI1 limits, scale, inversion) Setting the reference limits Setting the speed (reference) limits Setting the source and limits for the process actual value	1106 (1301...1303, 3001) 1107, 1108 2007, 2008 4016, 4018, 4019
Start/Stop control	Selecting the source for start and stop signals of the two external control locations, EXT1 and EXT2 Selecting between EXT1 and EXT2 Defining the direction control Defining the start and stop modes Selecting the use of Run Enable signal	1001, 1002 1002 1003 2101...2103 1601
Protections	Setting the current limits	2003
Output signals	Selecting the signals indicated through relay output RO Selecting the signals indicated through analog output AO Setting the minimum, maximum, scaling and inversion	Group 14: Relay outputs Group 15: Analogue outputs

Name	Description	Set parameters
Timed functions	Setting the timed functions Selecting the timed start/stop control for external control locations EXT1 and EXT2 Selecting timed EXT1/EXT2 control Activation of timed constant speed 1 Selecting timed function status indicated through relay output RO Selecting timed PID1 parameter set 1/2 control	Group 36: Timed functions 1001, 1002 1102 1201 1401 4027

■ Contents of the assistant displays

There are two types of displays in the Start-up assistant: Main displays and the information displays. The main displays prompt the user to feed in information. The assistant steps through the main displays. The information displays contain help texts for the main displays. The figure below shows a typical example of both and explanations of the contents.

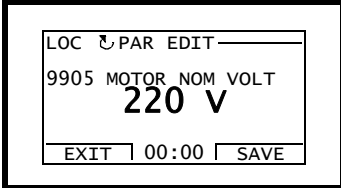
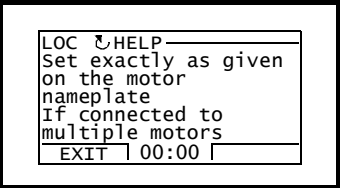
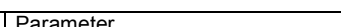
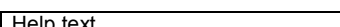
	Main display	Information display
1		
2		
1	Parameter	Help text ...
2	Feed-in field	... help text continued

Local control vs. external control

The drive can receive start, stop and direction commands and reference values from the control panel or through digital and analog inputs. Embedded fieldbus enables control over an open fieldbus link. A PC equipped with DriveWindow Light PC tool can also control the drive.

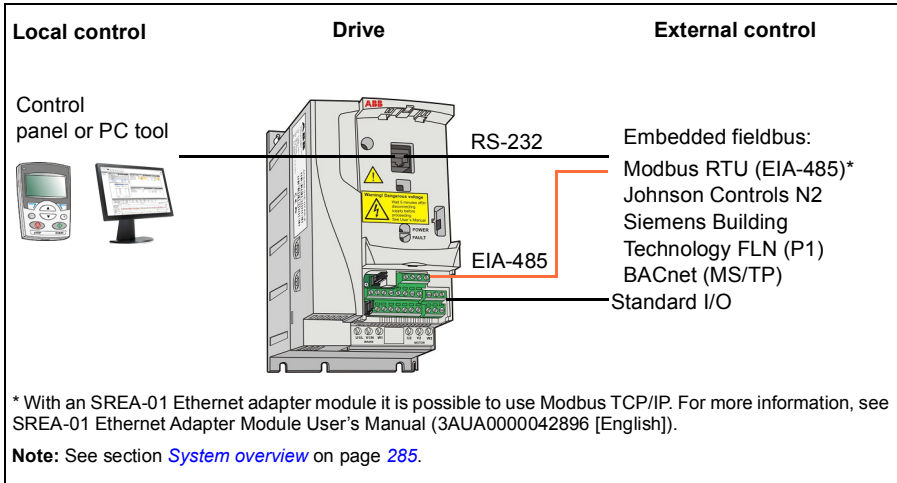

Local control

The control commands are given from the control panel keypad when the drive is in local control. LOC indicates local control on the panel display.

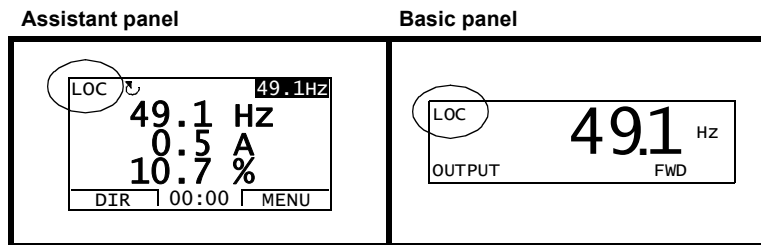

The control panel always overrides the external control signal sources when used in local mode.

External control

When the drive is in external control, the commands are given through the standard I/O terminals (digital and analog inputs) and/or the fieldbus interface. In addition, it is also possible to set the control panel as the source for the external control.

External control is indicated with REM on the panel display.

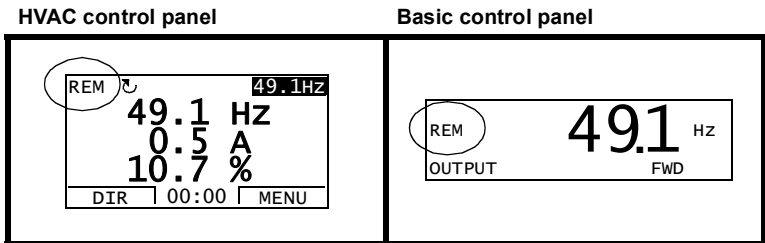

The user can connect the control signals to two external control locations, EXT1 or EXT2. Depending on the user selection, either one is active at a time. This function operates on a 2 ms time level.

Settings

Panel key	Additional information
LOC/REM	Selection between local and external control
Parameter	
1102	Selection between EXT1 and EXT2
1001/1002	Start, stop, direction source for EXT1/EXT2
1103/1106	Reference source for EXT1/EXT2

Diagnostics

Actual signals	Additional information
0111/0112	EXT1/EXT2 reference

Block diagram: Start, stop, direction source for EXT1

The figure below shows the parameters that select the interface for start, stop, and direction for external control location EXT1.

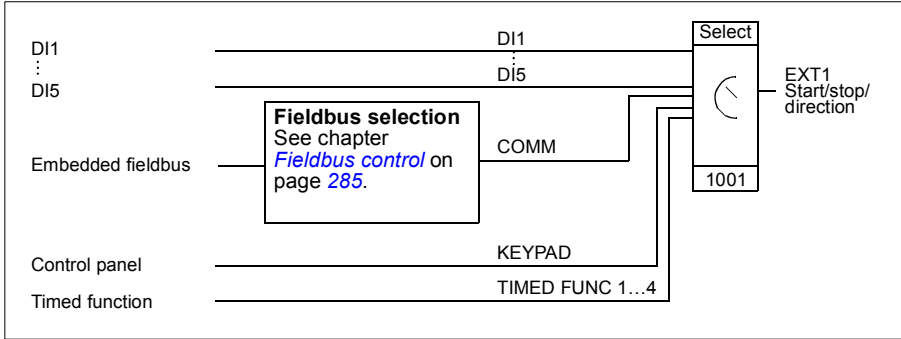

Block diagram: Reference source for EXT1

The figure below shows the parameters that select the interface for the speed reference of external control location EXT1.

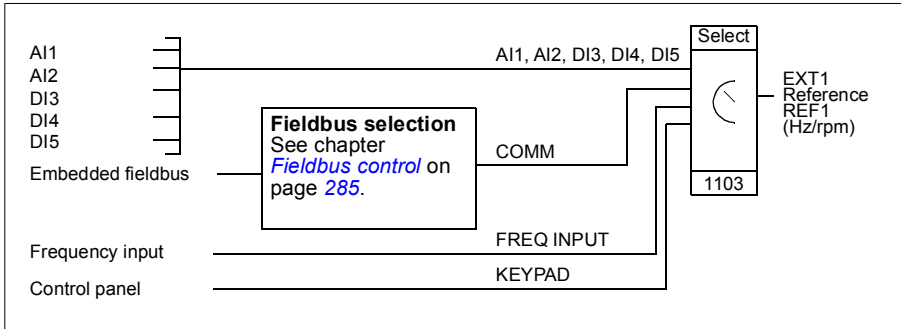

Reference types and processing

The drive can accept a variety of references in addition to the conventional analog input and control panel signals.

- The drive reference can be given with two digital inputs: One digital input increases the speed, the other decreases it.
- The drive can form a reference out of two analog input signals by using mathematical functions: Addition, subtraction, multiplication and division.
- The drive can form a reference out of an analog input signal and a signal received through a serial communication interface by using mathematical functions: Addition and multiplication.
- The drive reference can be given with frequency input.

It is possible to scale the external reference so that the signal minimum and maximum values correspond to a speed other than the minimum and maximum speed limits.

■ Settings

Parameter	Additional information
Group 11: Reference select	External reference source, type and scaling
Group 20: Limits	Operating limits
Group 22: Accel/Decel	Speed reference acceleration/deceleration ramps
Group 32: Supervision	Reference supervision

■ Diagnostics

Actual signal	Additional information
0111/0112	REF1/REF2 reference
Group 03: FB actual signals	References in different stages of the reference processing chain

Reference trimming

In reference trimming, the external reference is corrected depending on the measured value of a secondary application variable. The block diagram below illustrates the function.

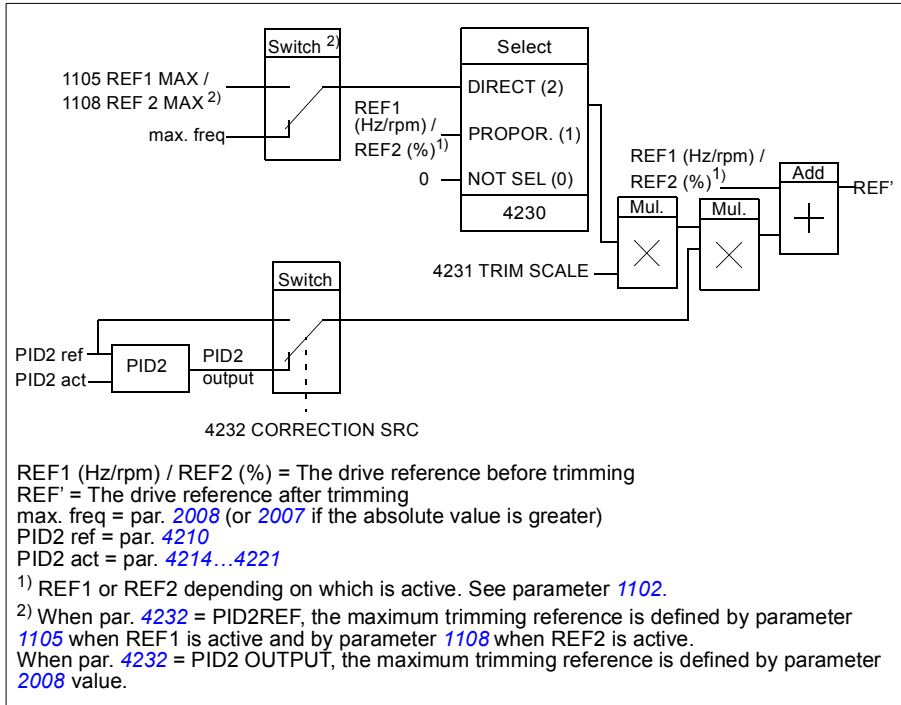

Settings

Parameter	Additional information
1102	REF1/2 selection
4230 ... 4232	Trimming function settings
4201 ... 4221, 4228, 4229	PID control settings
Group 20: Limits	Drive operation limits

Programmable analog inputs

The drive has two programmable analog voltage/current inputs. The inputs can be inverted, filtered and the maximum and minimum values can be adjusted. The update cycle for the analog input is 8 ms (12 ms cycle once per second). The cycle time is shorter when information is transferred to the application program (8 ms -> 2 ms).

■ Settings

Parameter	Additional information
<i>Group 11: Reference select</i>	AI as reference source
<i>Group 13: Analogue inputs</i>	Analog input processing
<i>3001, 3021, 3022, 3107</i>	AI loss supervision
<i>Group 35: Motor temp meas</i>	AI in motor temperature measurement
<i>Group 40: Process PID set 1</i> ... <i>Group 42: Ext / Trim PID</i>	AI as PID process control reference or actual value source
<i>Group 44: Pump protection</i>	AI as pump protection measurement source

■ Diagnostics

Actual signal	Additional information
<i>0120, 0121</i>	Analog input values
<i>1401</i>	AI1/A2 signal loss
Alarm	
<i>AI1 LOSS / AI2 LOSS</i>	AI1/AI2 signal below AI1/AI2 FAULT LIMIT (<i>3021/3022</i>)
Fault	
<i>AI1 LOSS / AI2 LOSS</i>	AI1/AI2 signal below limit AI1/AI2 FAULT LIMIT (<i>3021/3022</i>)
<i>PAR AI SCALE</i>	Incorrect AI signal scaling (<i>1302 < 1301</i> or <i>1305 < 1304</i>)

Programmable analog output

One programmable current output (0 ... 20 mA) is available. Analog output signal can be inverted, filtered and the maximum and minimum values can be adjusted. The analog output signals can be proportional to motor speed, output frequency, output current, motor torque, motor power, etc. The update cycle for the analog output is 2 ms.

It is also possible to write a value to an analog output through a serial communication link.

■ Settings

Parameter	Additional information
Group 15: Analogue outputs	AO value selection and processing
Group 35: Motor temp meas	AO in motor temperature measurement

■ Diagnostics

Actual signal	Additional information
0124	AO value
Fault	
PAR AO SCALE	Incorrect AO signal scaling (1503 < 1502)

Programmable digital inputs

The drive has five programmable digital inputs. The update time for the digital inputs is 2 ms.

It is possible to delay the state change of digital inputs with delays defined in group [Group 18: Freq in & tran out](#). This enables very simple program sequences by connecting several functions with the same physical wire, eg, to remove branches and leaves from a pipe by running the fan in reverse before normal operation.

One digital input (DI5) can be programmed as a frequency input. See section [Frequency input](#) on page 113.

■ Settings

Parameter	Additional information
Group 10: Start/Stop/Dir	DI as start, stop, direction
Group 11: Reference select	DI in reference selection, or reference source
Group 12: Constant speeds	DI in constant speed selection
Group 16: System controls	DI as external Run Enable, fault reset or user macro change signal
Group 18: Freq in & tran out	Delays in DI state changes
2115	Selects the source for controlling motor heating.
2109	DI as external emergency stop command source
2201	DI as acceleration and deceleration ramp selection signal
2209	DI as zero ramp force signal
3003	DI as external fault source
Group 35: Motor temp meas	DI in motor temperature measurement
3601	DI as timed function enable signal source
3622	DI as booster activation signal source
4010/4110/4210	DI as PID controller reference signal source
4022/4122	DI as sleep function activation signal in PID1
4027	DI as PID1 parameter set 1/2 selection signal source
4034/4035	DI as PID reference/output freezing source
4039/4139	DI as PID internal setpoint selection source
4228	DI as external PID2 function activation signal source
4406/4414	DI as connection signal source for pump inlet/outlet pressure switch
4421	DI as pipe fill enable source
4601	DI as pump clean trigger source
6403	DI as load analyzer logger reset source
8120	DI as PFA interlock source

■ Diagnostics

Actual signal	Additional information
0160	DI status
0414	DI status at the time the latest fault occurred

Programmable relay output

The drive has one programmable relay output. It is possible to add three additional relay outputs with the optional MREL-0 relay output extension module. For more information, see *MREL-01 output relay module user's manual* (3AUA0000035974 [English]).

With a parameter setting it is possible to choose what information to indicate through the relay output: Ready, running, fault, alarm, etc. The update time for the relay output is 2 ms.

A value can be written to a relay output through a serial communication link.

■ Settings

Parameter	Additional information
Group 14: Relay outputs	RO value selections and operation times

■ Diagnostics

Actual signal	Additional information
0134	RO Control Word through fieldbus control
0162	RO 1 status
0173	RO 2...4 status. With option MREL-01 only.

Frequency input

Digital input DI5 can be programmed as a frequency input. Frequency input (0...16000 Hz) can be used as external reference signal source. The update time for the frequency input is 50 ms. Update time is shorter when information is transferred to the application program (50 ms -> 2 ms).

■ Settings

Parameter	Additional information
<i>Group 18: Freq in & tran out</i>	Frequency input minimum and maximum values and filtering
<i>1103/1106</i>	External reference REF1/2 through frequency input
<i>4010, 4110, 4210</i>	Frequency input as PID reference source

■ Diagnostics

Actual signal	Additional information
<i>0161</i>	Frequency input value

Transistor output

The drive has one programmable transistor output. The output can be used either as digital output or frequency output (0...16000 Hz). The update time for the transistor/frequency output is 2 ms.

■ Settings

Parameter	Additional information
<i>Group 18: Freq in & tran out</i>	Transistor output settings

■ Diagnostics

Actual signal	Additional information
<i>0163</i>	Transistor output status
<i>0164</i>	Transistor output frequency

Actual signals

Several actual signals are available:

- Drive output frequency, current, voltage and power
- Motor speed and torque
- Intermediate circuit DC voltage
- Active control location (LOCAL, EXT1 or EXT2)
- Reference values
- Drive temperature
- Operating time counter (h), kWh counter
- Digital I/O and analog I/O status
- PID controller actual values.

Three signals can be shown simultaneously on the assistant control panel display (one signal on the basic panel display). It is also possible to read the values through the serial communication link or through the analog outputs.

■ Settings

Parameter	Additional information
1501	Selection of an actual signal to AO
1801	Selection of an actual signal to frequency output
Group 32: Supervision	Actual signal supervision
Group 34: Panel display	Selection of an actual signals to be displayed on the control panel

■ Diagnostics

Actual signal	Additional information
Group 01: Operating data ... Group 04: Fault history	Lists of actual signals

Power loss ride-through

If the incoming supply voltage is cut off, the drive will continue to operate by utilizing the kinetic energy of the rotating motor. The drive will be fully operational as long as the motor rotates and generates energy to the drive. The drive can continue the operation after the break if the main contactor remained closed.

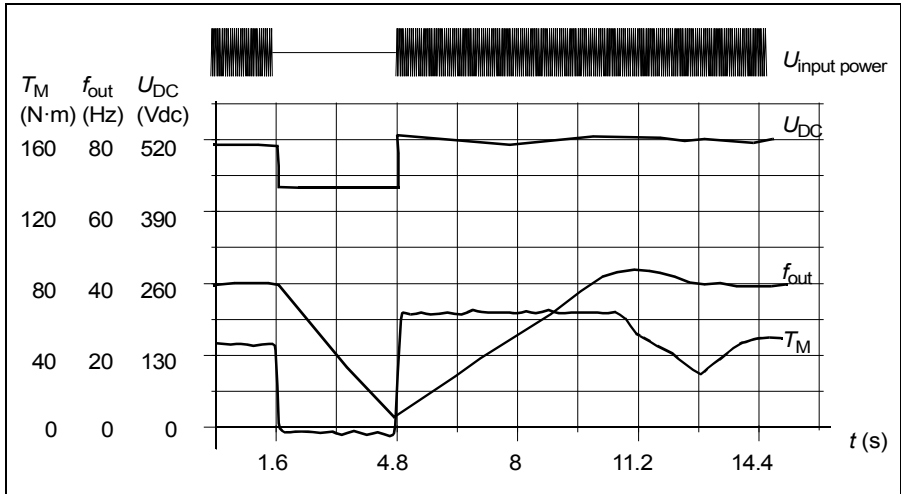

U_{DC} = Intermediate circuit voltage of the drive, f_{out} = Output frequency of the drive, T_M = Motor torque

Loss of supply voltage at nominal load ($f_{out} = 40$ Hz). The intermediate circuit DC voltage drops to the minimum limit. The controller keeps the voltage steady as long as the input power is switched off. The drive runs the motor in generator mode. The motor speed falls but the drive is operational as long as the motor has enough kinetic energy.

■ Settings

Parameter [2006 UNDERVOLT CTRL](#)

DC magnetizing

When DC Magnetizing is activated, the drive automatically magnetizes the motor before starting. This feature guarantees the highest possible breakaway torque, up to 180% of the motor nominal torque. The Automatic Start feature and DC Magnetizing cannot be activated at the same time.

■ Settings

Parameters [2101 START FUNCTION](#) and [2103 DC MAGN TIME](#)

Maintenance trigger

A maintenance trigger can be activated to show a notice on the panel display when, for example, drive power consumption has exceeded the defined trigger point.

■ Settings

Parameter [Group 29: Maintenance trig](#)

Acceleration and deceleration ramps

Two user-selectable acceleration and deceleration ramps are available. It is possible to adjust the acceleration/deceleration times and the ramp shape. Switching between the two ramps can be controlled via a digital input or fieldbus.

The available ramp shape alternatives are Linear and S-curve.

Linear: Suitable for drives requiring steady or slow acceleration/deceleration.

S-curve: Ideal for conveyors carrying fragile loads, or other applications where a smooth transition is required when changing the speed.

■ Settings

Parameter [Group 22: Acce/Decel](#)

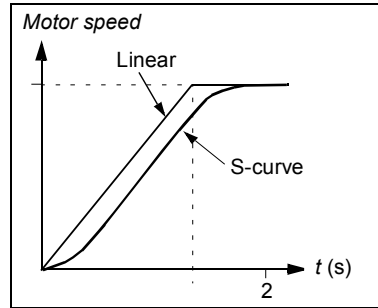

Critical speeds

A Critical Speeds function is available for applications where it is necessary to avoid certain motor speeds (drive output frequencies) or speed bands (output frequency bands) because of, for example, mechanical resonance problems. The user can define three critical frequencies or frequency bands.

■ Settings

Parameter [Group 25: Critical speeds](#)

Constant speeds

It is possible to define seven positive constant speeds. Constant speeds are selected with digital inputs. Constant speed activation overrides the external speed reference.

Constant speed selections are ignored if

- PID reference is being followed, or
- drive is in local control mode.

This function operates on a 2 ms time level.

■ Settings

Parameter [Group 12: Constant speeds](#)

Constant speed 7 (*1208 CONST SPEED 7*) is also used for fault functions. See parameter group [Group 30: Fault functions](#).

Custom U/f ratio

The user can define a U/f curve (output voltage as a function of frequency). This custom ratio is used only in special applications where linear and squared U/f ratio are not sufficient (eg, when motor break-away torque needs to be boosted).

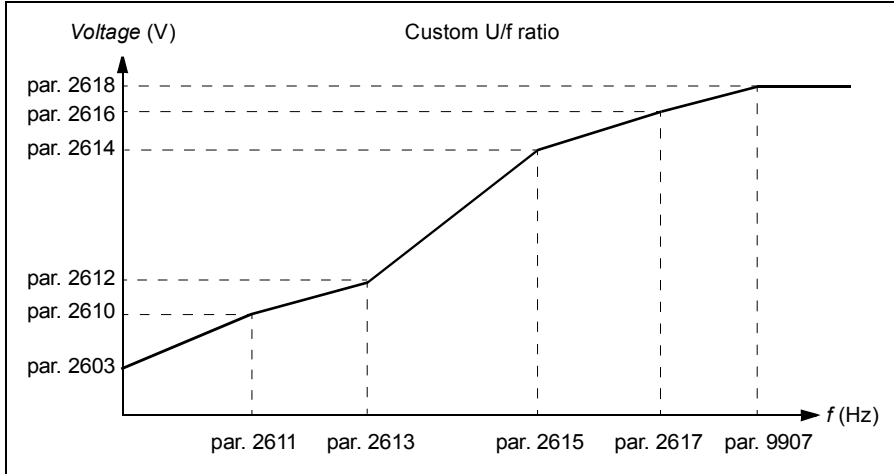

Note: The voltage and the frequency points of the U/f curve must fulfill the following requirements:

$$2610 < 2612 < 2614 < 2616 < 2618 \text{ and} \\ 2611 < 2613 < 2615 < 2617 < 9907$$



WARNING! High voltage at low frequencies may result in poor performance or motor damage (overheating).

Settings

Parameter	Additional information
2605	Custom U/f ratio activation
2610...2618	Custom U/f ratio settings

Diagnostics

Fault	Additional information
PAR CUSTOM U/F	Incorrect U/f ratio

R compensation

When IR compensation is activated, the drive gives an extra voltage boost to the motor at low speeds. IR compensation is useful in applications that require high breakaway torque.

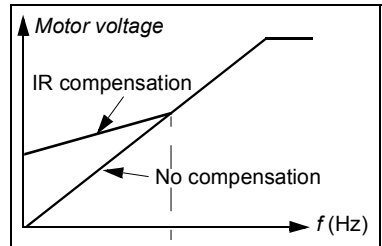

Settings

Parameter [2603 IR COMP VOLT](#)

Programmable protection functions

AI<Min

AI<Min function defines the drive operation if an analog input signal falls below the set minimum limit.

Settings

Parameters [3001 AI<MIN FUNCTION](#), [3021 AI1 FAULT LIMIT](#) and [3022 AI2 FAULT LIMIT](#)

Panel loss

The Panel loss function defines the operation of the drive if the control panel selected as control location for the drive stops communicating.

Settings

Parameter [3002 PANEL COMM ERR](#)

External fault

External faults (1 and 2) can be supervised by defining one digital input as a source for an external fault indication signal.

Settings

Parameters [3003 EXTERNAL FAULT 1](#) and [3004 EXTERNAL FAULT 2](#)

Stall protection

The drive protects the motor in a stall situation. It is possible to adjust the supervision limits (frequency, time) and choose how the drive reacts to the motor stall condition (alarm indication / fault indication & drive stop / no reaction).

Settings

Parameters [3010 STALL FUNCTION...](#)[3012 STALL TIME](#)

■ Motor thermal protection

The motor can be protected against overheating by activating the Motor thermal protection function.

The drive calculates the temperature of the motor on the basis of the following assumptions:

1. The motor is in the ambient temperature of 30 °C when power is applied to the drive.
2. Motor temperature is calculated using either the user-adjustable or automatically calculated motor thermal time constant and motor load curve (see the figures below). The load curve should be adjusted in case the ambient temperature exceeds 30 °C.

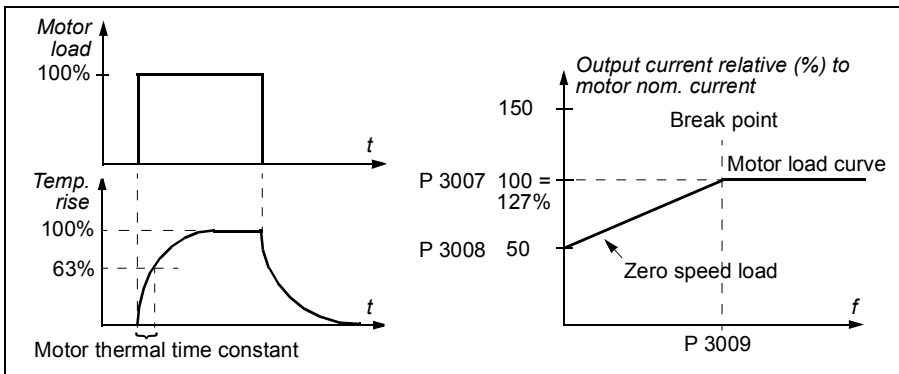

Settings

Parameters [3005 MOT THERM PROT...](#) [3007 BREAK POINT FREQ](#)

Note: It is also possible to use the motor temperature measurement function. See section [Motor temperature measurement through the standard I/O](#) on page 129.

■ Earth fault protection

The Earth fault protection function detects ground faults in the motor or motor cable. The protection is active only during start.

A ground fault in the input power line does not activate the protection.

Settings

Parameter [3017 EARTH FAULT](#)

■ Incorrect wiring

Defines the operation when incorrect input power cable connection is detected.

Settings

Parameter [3023 WIRING FAULT](#)

Preprogrammed faults

■ Overcurrent

The overcurrent trip limit for the drive is 325% of the drive nominal current.

■ DC overvoltage

The DC overvoltage trip limit is 420 V (for 200 V drives) and 840 V (for 400 V drives).

■ DC undervoltage

The DC undervoltage trip limit is adaptive. See parameter [2006 UNDERVOLT CTRL.](#)

■ Drive temperature

The drive supervises the IGBT temperature. There are two supervision limits: Alarm limit and fault trip limit.

■ Short circuit

If a short circuit occurs, the drive will not start and a fault indication is given.

■ Internal fault

If the drive detects an internal fault, the drive is stopped and a fault indication is given.

■ Supply phase loss

If the drive detects supply phase loss (excessive DC voltage ripple), the drive is stopped and a fault indication is given.

Operation limits

The drive has adjustable limits for output frequency, current (maximum) and DC voltage.

■ Settings

Parameter [Group 20: Limits](#)

Power limit

Power limitation is used to protect the input bridge and the DC intermediate circuit. If the maximum allowed power is exceeded, the drive torque is automatically limited. Maximum overload and continuous power limits depend on the drive hardware. For specific values, see chapter [Technical data](#) on page 385.

Automatic resets

The drive can automatically reset itself after overcurrent, overvoltage, undervoltage, external and “analog input below a minimum” faults. The Automatic Resets must be activated by the user.

■ Settings

Parameter	Additional information
Group 31: Automatic reset	Automatic reset settings

■ Diagnostics

Alarm	Additional information
AUTORESET	Automatic reset alarm

Supervisions

The drive monitors whether certain user selectable variables are within the user-defined limits. The user may set limits for speed, current etc. The supervision status can be indicated through relay or digital output.

The supervision function outputs can be used for triggering some drive functionality (start/stop, sleep, pump cleaning).

The supervision functions operate on a 2 ms time level.

■ Settings

Parameter group [Group 32: Supervision](#)

■ Diagnostics

Actual signal	Additional information
1001/1002	EXT1/EXT2 start/stop according to supervision functions
1401	Supervision status through RO 1
1402/1403/1410	Supervision status through RO 2...4. With option MREL-01 only.
1805	Supervision status through DO
4022/4122	Sleep start according to supervision functions
4601	Pump clean trigger according to supervision functions

Parameter lock

The user can prevent parameter adjustment by activating the parameter lock.

■ Settings

Parameters [1602 PARAMETER LOCK](#) and [1603 PASS CODE](#)

PID control

There are two built-in PID controllers in the drive:

- Process PID (PID1) and
- External/Trim PID (PID2).

The PID controller can be used when the motor speed needs to be controlled based on process variables such as pressure, flow or temperature.

When the PID control is activated, a process reference (setpoint) is connected to the drive instead of a speed reference. An actual value (process feedback) is also brought back to the drive. The drive compares the reference and the actual values, and automatically adjusts the drive speed in order to keep the measured process quantity (actual value) at the desired level (reference).

The control operates on a 2 ms time level.

■ Process controller PID1

PID1 has two separate sets of parameters ([Group 40: Process PID set 1](#), [Group 41: Process PID set 2](#)). Selection between parameter sets 1 and 2 is defined by a parameter.

In most cases when there is only one transducer signal wired to the drive, only parameter set 1 is needed. Two different parameter sets (1 and 2) are used, eg, when the load of the motor changes considerably in time.

■ External/Trim controller PID2

PID2 ([Group 42: Ext / Trim PID](#)) can be used in two different ways:

- External controller: Instead of using additional PID controller hardware, the user can connect PID2 output via drive analog output or fieldbus controller to control a field instrument like a damper or a valve.
 - Trim controller: PID2 can be used to trim or fine tune the reference of the drive. See section [Reference trimming](#) on page [108](#).
-

■ Block diagrams

The figure below shows an application example: The controller adjusts the speed of a pressure boost pump according to the measured pressure and the set pressure reference.

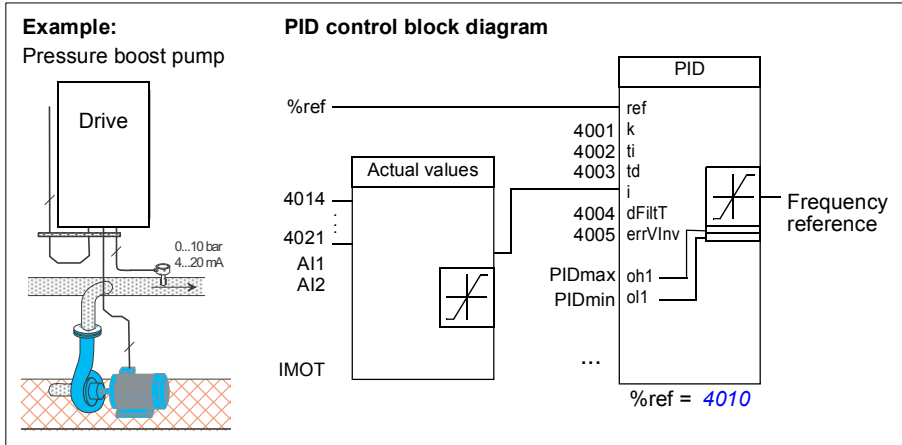

The following figure presents the speed/scalar control block diagram for process controller PID1.

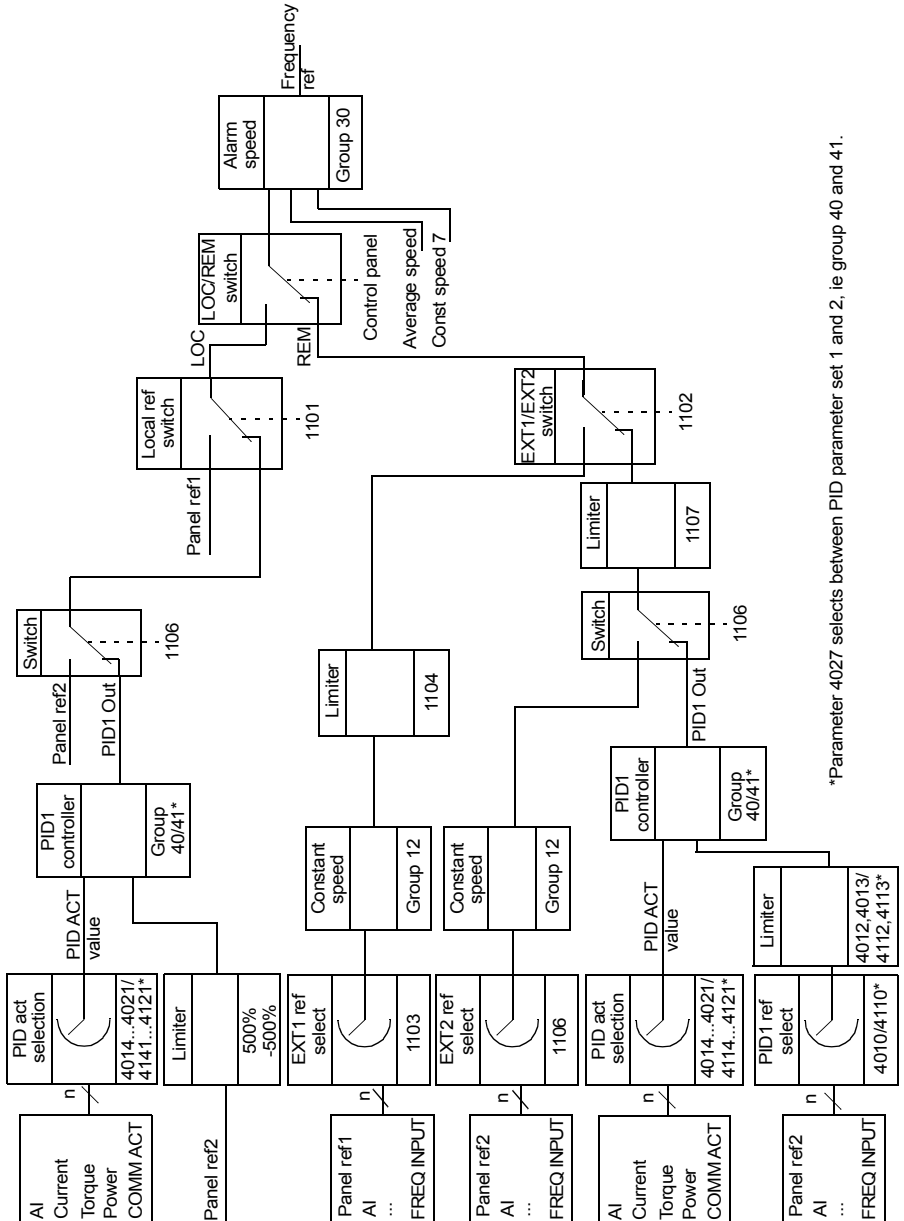

*Parameter 4027 selects between PID parameter set 1 and 2, ie group 40 and 41.

■ Settings

Parameter	Additional information
1101	Local control mode reference type selection
1102	EXT1/2 selection
1106	PID1 activation
1107	REF2 minimum limit
1501	PID2 output (external controller) connection to AO
9902	PID control macro selection
<i>Group 40: Process PID set 1...Group 41: Process PID set 2</i>	PID1 settings
<i>Group 42: Ext / Trim PID</i>	PID2 settings

■ Diagnostics

Actual signal	Additional information
0126/0127	PID 1/2 output value
0128/0129	PID 1/2 setpoint value
0130/0131	PID 1/2 feedback value
0132/0133	PID 1/2 deviation

Sleep function for the process PID (PID1) control

The sleep function operates on a 2 ms time level.

The block diagram below illustrates the sleep function enable/disable logic. The sleep function can be put into use only when the PID control is active.

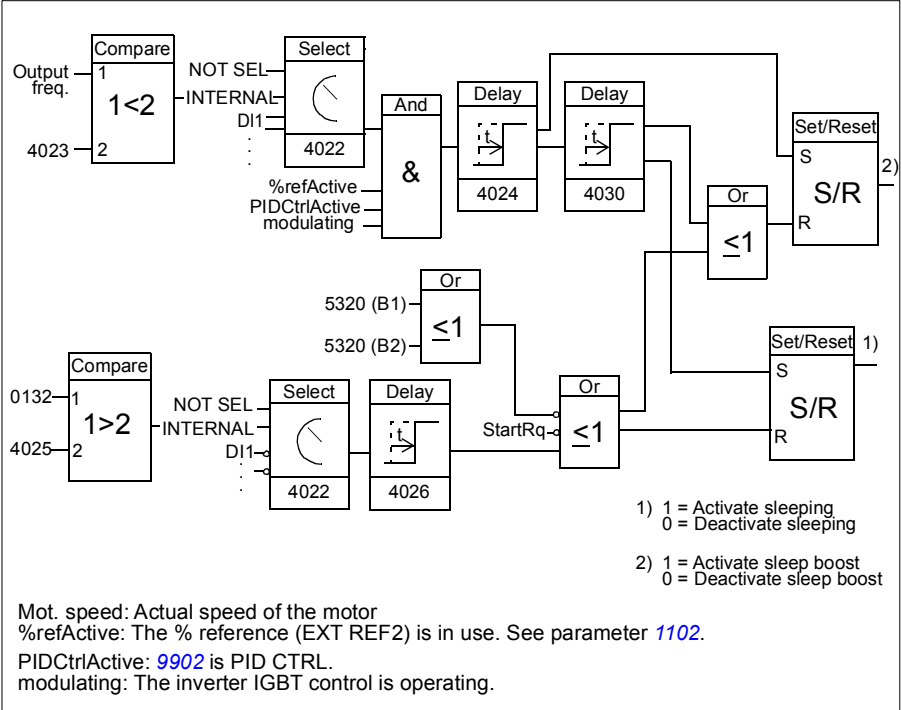

Example

The time scheme below visualizes the operation of the sleep function.

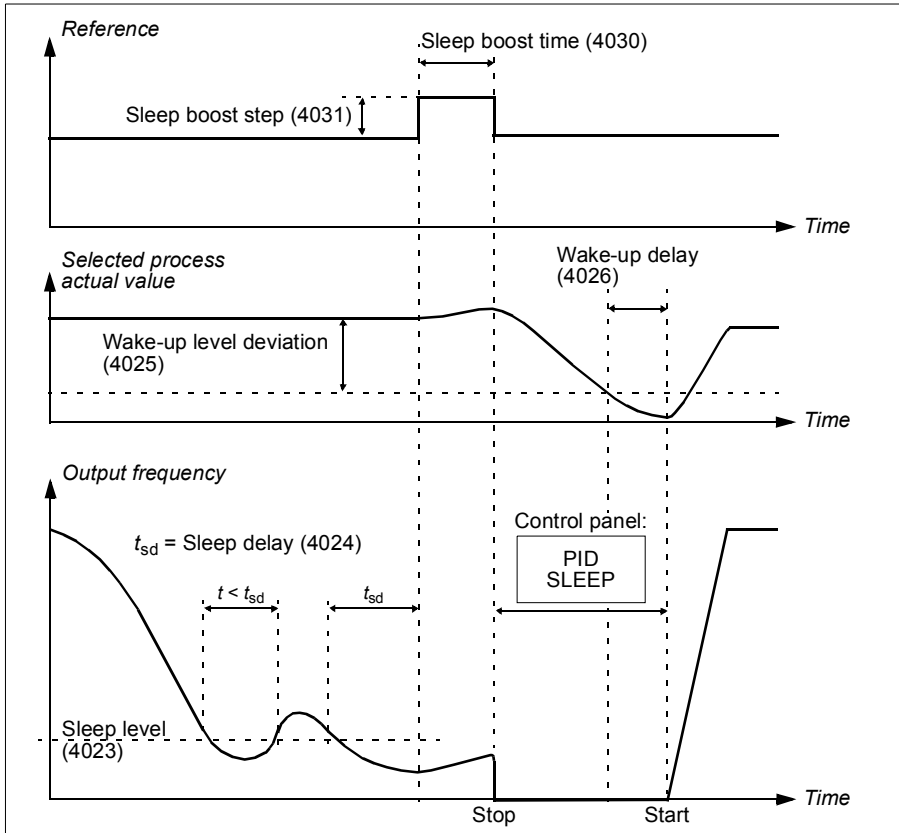

Sleep function for a PID controlled pressure boost pump (when parameter [4022 SLEEP SELECTION](#) is set to INTERNAL): The water consumption falls at night. As a consequence, the PID process controller decreases the motor speed. However, due to natural losses in the pipes and the low efficiency of the centrifugal pump at low speeds, the motor does not stop but keeps rotating. The sleep function detects the slow rotation, and stops the unnecessary pumping after the sleep delay has passed. The drive shifts into sleep mode, still monitoring the pressure. The pumping restarts when the pressure falls under the allowed minimum level and the wake-up delay has passed.

■ Settings

Parameter	Additional information
9902	PID control activation
4022...4026, 4030, 4031, 4122...4126, 4130, 4131	Sleep function settings

■ Diagnostics

Parameter	Additional information
1401	PID sleep function status through RO 1
1402/1403/1410	PID sleep function status through RO 2...4. With option MREL-01 only.
Alarm	Additional information
PID SLEEP	Sleep mode

Motor temperature measurement through the standard I/O

This section describes the temperature measurement of one motor when the drive I/O terminals are used as the connection interface.

Motor temperature can be measured using PT100 or PTC sensors connected to analog input and output.

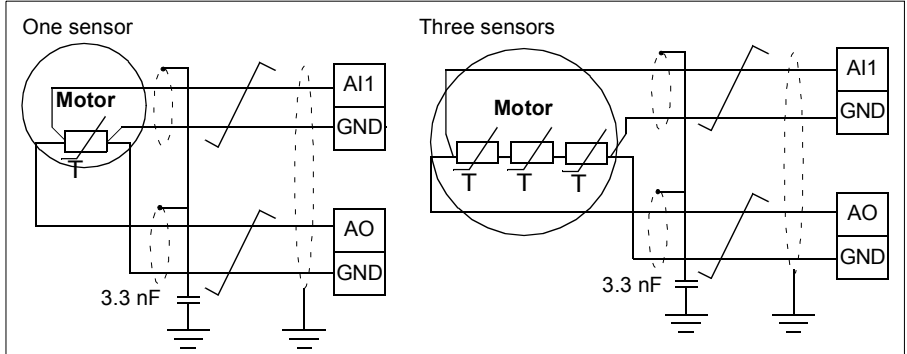



WARNING! IEC 60664 requires double or reinforced insulation between live parts and the surface of accessible parts of electrical equipment which are either non-conductive or conductive but not connected to the protective earth. Reinforced insulation entails a clearance and creepage distance of 8 mm (400/500 V AC equipment).

If the assembly does not fulfill the requirement, the I/O board terminals must be protected against contact and they may not be connected to other equipment, or the temperature sensor must be isolated from the I/O terminals.

To connect a motor temperature sensor and other similar components to the drive, you have below alternatives:

- If there is double or reinforced insulation between the sensor and the live parts of the motor, you can connect the sensor directly to the inputs of the drive.
- If there is basic insulation between the sensor and the live parts of the motor, you can connect the sensor to the inputs of the drive if all circuits connected to the drive's digital and analog inputs (typically extra-low voltage circuits) are protected against contact and insulated with basic insulation from other low-voltage circuits. The insulation must be rated for the same voltage level as the drive main circuit. Note that extra-low voltage circuits (such as 24 V DC) typically do not meet these requirements.
- You can connect a sensor to an external thermistor relay the insulation of which is rated for the main circuit voltage of the drive.

The figure below shows alternate thermistor connections. At the motor end the cable shield should be grounded through a 10 nF capacitor. If this is not possible, leave the shield unconnected.

It is also possible to monitor motor temperature by connecting a PTC sensor and a thermistor relay between the +24 V DC voltage supply offered by the drive and a digital input. The figure below displays the connection.

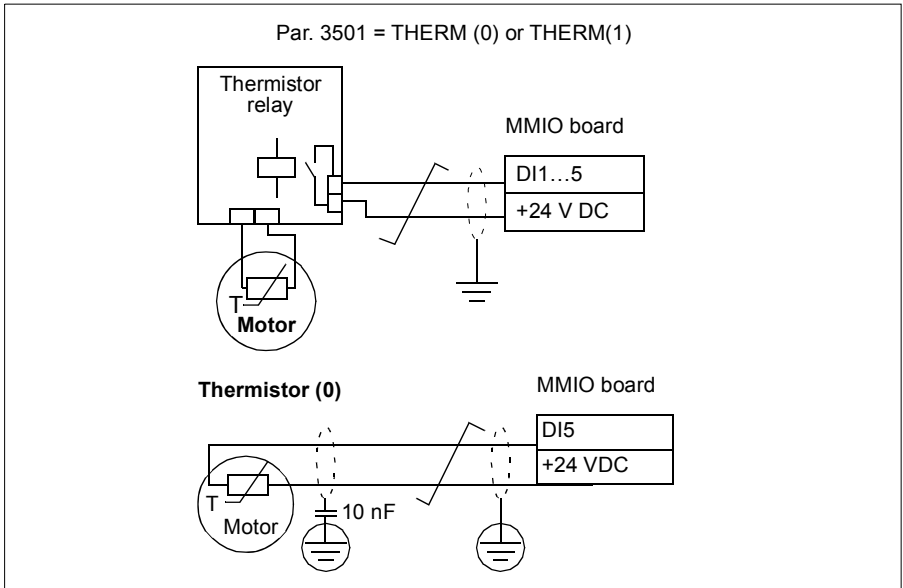

For other faults, or for anticipating motor overheating using a model, see [Group 30: Fault functions](#).

Settings

Parameter	Additional information
Group 13: Analogue inputs	Analog input settings
Group 15: Analogue outputs	Analog output settings
Group 35: Motor temp meas	Motor temperature measurement settings
Other	
At the motor end the cable shield should be grounded through a 10 nF capacitor. If this is not possible, the shield is to be left unconnected.	

Diagnostics

Actual value	Additional information
0145	Motor temperature
Alarm/Fault	
MOTOR TEMP/MOT OVERTEMP	Excessive motor temp

Timed functions

A variety of drive functions can be time controlled, eg start/stop and EXT1/EXT2 control. The drive offers

- four start and stop times (START TIME 1...4, STOP TIME 1...4)
- four start and stop days (START DAY 1...4, STOP DAY 1...4)
- four timed functions for collecting the selected time periods 1...4 together (TIMED FUNC 1...4)
- booster time (an additional booster time connected to timed functions).

A timed function can be connected to multiple time periods:

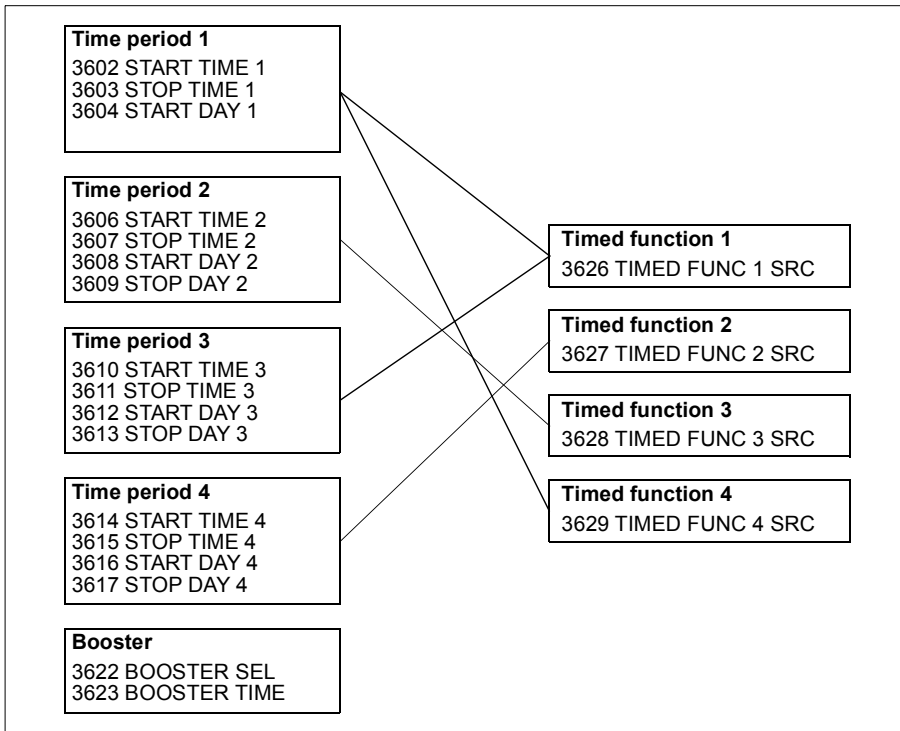

A parameter which is triggered by a timed function can be connected to only one timed function at a time.

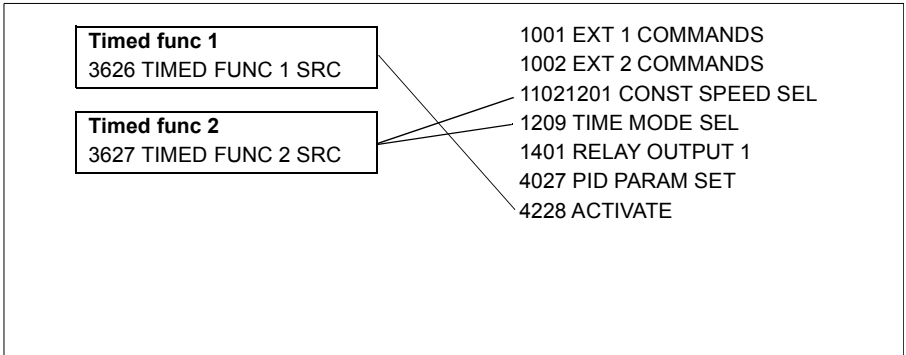

Examples

Air conditioning is active on weekdays from 8:00 to 15:30 (8 a.m to 3:30 p.m) and on Sundays from 12:00 to 15:00 (12 to 3 p.m). By pressing the extension time switch, the air-conditioning is on for an extra hour.

Parameter	Setting
<i>3601 TIMERS ENABLE</i>	DI1
<i>3602 START TIME 1</i>	08:00:00
<i>3603 STOP TIME 1</i>	15:30:00
<i>3604 START DAY 1</i>	MONDAY
<i>3605 STOP DAY 1</i>	FRIDAY
<i>3606 START TIME 2</i>	12:00:00
<i>3607 STOP TIME 2</i>	15:00:00
<i>3608 START DAY 2</i>	SUNDAY
<i>3609 STOP DAY 2</i>	SUNDAY
<i>3623 BOOSTER TIME</i>	01:00:00

Settings

Parameter	Additional information
<i>Group 36: Timed functions</i>	Timed functions settings
<i>1001, 1002</i>	Timed start/stop control
<i>1102</i>	Timed EXT1/EXT2 selection
<i>1201</i>	Timed constant speed 1 activation
<i>1209</i>	Timed speed selection
<i>1401</i>	Timed function status indicated through relay output RO 1
<i>1402/1403/1410</i>	Timed function status indicated through relay output RO 2...4. With option MREL-01 only.

Parameter	Additional information
1805	Timed function status indicated through digital output DO
4027	Timed PID1 parameter set 1/2 selection
4228	Timed external PID2 activation

User load curve

The user can specify a load curve (motor torque as a function of frequency) for supervision. The curve is defined by five points. Supervision can be set for the torque dropping below the underload curve, exceeding the overload curve, or both.

A fault is generated if the torque has been out of the allowed area for longer than the user-defined time limit. An alarm is generated if the torque has been out of the allowed area for longer than the half of the user-defined time limit.

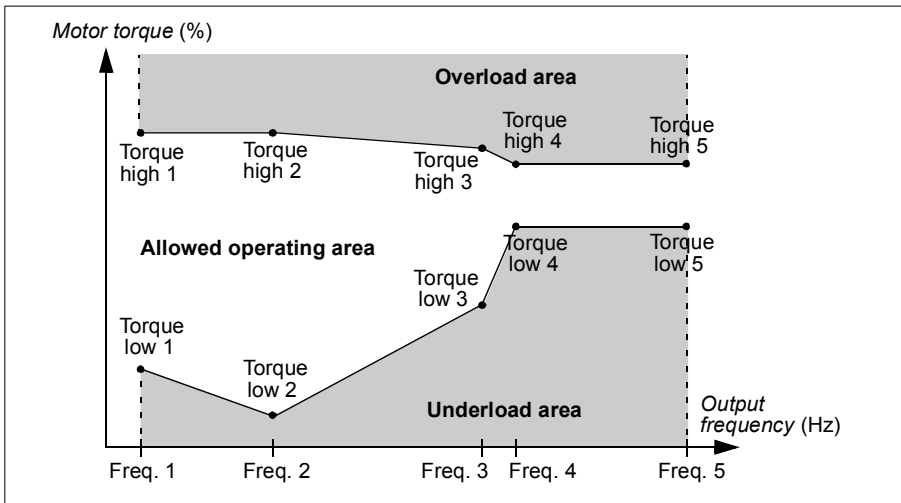

■ Settings

Parameter	Additional information
Group 37: User load curve	User load curve settings

■ Diagnostics

Actual signal	Additional information
<i>0105</i>	Motor torque
Alarm	
<i>USER LOAD CURVE</i>	Out of allowed area for longer than half of the defined time limit
Fault	
<i>USER LOAD CURVE</i>	Out of allowed area for longer than the defined time limit
<i>PAR USER LOAD C</i>	Incorrect user load curve parameter setting (<i>3704 > 3707</i> or <i>3707 > 3710</i> or <i>3710 > 3713</i> or <i>3713 > 3716</i> or <i>3705 > 3706</i> or <i>3708 > 3709</i> or <i>3711 > 3712</i> or <i>3714 > 3715</i> or <i>3717 > 3718</i>)

Energy optimizer

Energy optimizer optimizes the flux so that the total energy consumption and motor noise level are reduced when the drive operates below the nominal load. The total efficiency (motor and drive) can be improved by 1 ... 10% depending on the load torque and speed.

■ Settings

Parameter	Additional information
<i>4501 ENERGY OPTIMIZER</i>	Energy optimizer enabling

Energy saving

Energy saving tools calculate energy saved in kWh and MWh, energy saved in local currency as well as reduction in CO₂ emission, all compared to the situation when the pump is connected directly to the supply.

Two actual signals, *0176 SAVED AMOUNT 1* and *0177 SAVED AMOUNT 2* are used to store the energy saved in local currency. To find out the total saved energy in currency units, add the value of signal *0177* multiplied by 1000 to the value of signal *0176*.

Example:

0176 SAVED AMOUNT 1 = 123.4

0177 SAVED AMOUNT 2 = 5

Total saved energy = 5 · 1000 + 123.4 = 5123.4 currency units.

Note: The values of saved energy parameters *0174 SAVED KWH*, *0175 SAVED MWH*, *0176 SAVED AMOUNT 1*, *0177 SAVED AMOUNT 2* and *0178 SAVED CO2* are derived from subtracting the drive's energy consumed from the direct-on-line (DOL) consumption calculated on the basis of parameter *4508 PUMP POWER*. As such, the accuracy of the values is dependent on the accuracy of the power estimate entered in that parameter.

■ Settings

Parameter	Additional information
<i>Group 45: Energy saving</i>	Energy saving settings

■ Diagnostics

Actual signal	Additional information
<i>0174/0175</i>	Energy saved in kWh/Mwh
<i>0176/0177</i>	Energy saved in local currency
<i>0178</i>	Reduction in CO ₂ emission

Pump cleaning

The Pump cleaning function can be used for preventing solids from building up on pump impellers. The function consists of a programmable sequence of forward and reverse runs of the pump (see the figure below), effectively shaking off any residue on the impeller. This is especially useful with booster and wastewater pumps.

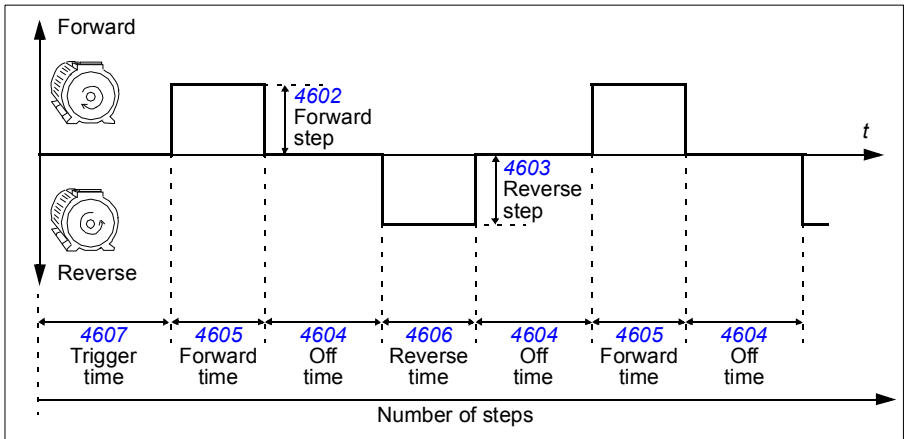

The pump cleaning cycle can be activated at start-up, with a user-defined period, with a selectable digital input or by the Supervision function (for example triggered by the motor input current).

■ Settings

Parameter	Additional information
Group 46: Pump cleaning	Pump cleaning settings
2205/2206	Acceleration time 2 / Deceleration time 2

Load analyzer

The load analyzer can be used for analyzing the customer's process and sizing the drive and the motor.

■ Peak value logger

The user can select a signal ([Group 01: Operating data](#)) to be monitored by the peak value logger (PVL). The signal is sampled at 2 ms intervals when the drive is running. The logger records the peak (maximum) value of the signal along with the time the peak occurred, as well as output current, DC voltage and output frequency at the time of the peak.

■ Amplitude loggers

The drive has two amplitude loggers.

For amplitude logger 2 (AL2), the user can select a signal ([Group 01: Operating data](#)) to be sampled at 200 ms intervals when the drive is running, and specify a value that corresponds to 100%. The collected samples are sorted into 10 read-only parameters according to their amplitude. Each parameter represents an amplitude range 10 percentage points wide, and displays the percentage of the collected samples that fall within that range.

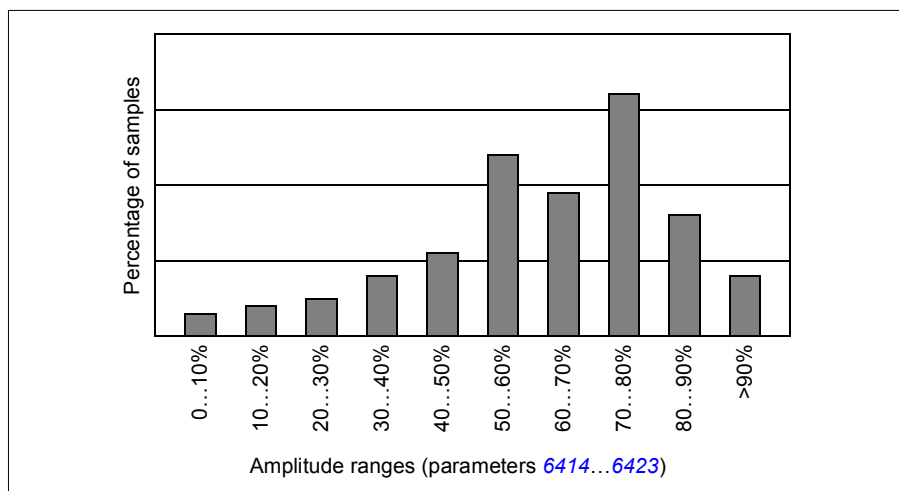

Amplitude logger 1 (AL1) is fixed to monitor output current, and it cannot be reset. With amplitude logger 1, 100% corresponds to the nominal output current of the drive (I_{2N}).

The peak value logger and amplitude logger 2 can be reset by a user-defined method. They are also reset if either of the signals or the peak value filter time is changed.

■ Settings

Parameter	Additional information
Group 64: Load analyzer, parameters 6401...6405	Load analyzer settings

■ Diagnostics

Actual signal	Additional information
Group 64: Load analyzer, parameters 6406...6433	Load analyzer results

PFA control (Requires use of MREL-01 option purchased separately)

■ PFA control

The pump and fan alternation (PFA) control switches auxiliary pumps on and off as required by capacity changes. The Autochange function alternates between pumps to keep the duty times of the pumps equal. Interlocks function enables the drive to detect if any of the pumps are unavailable (for example, switched off for maintenance), in which case the next available pump is started instead.

The drive controls the motor of pump 1, varying the motor speed to control the pump capacity. This motor is the speed regulated motor.

Direct line connections power the motor of pump 2 and pump 3, etc. The drive switches pump 2 (and then pump 3, etc.) on and off as needed. These motors are auxiliary motors.

The drive PID control uses two signals: a process reference and an actual value feedback. The PID controller adjusts the speed (frequency) of the first pump such that the actual value follows the process reference.

When demand (defined by the process reference) exceeds the first motor's capacity (user defined as a frequency limit), the PFA control automatically starts an auxiliary pump. The PFA control also reduces the speed of the first pump to account for the auxiliary pump's addition to total output. Then, as before, the PID controller adjusts the speed (frequency) of the first pump such that the actual value follows the process reference. If demand continues to increase, the PFA control adds additional auxiliary pumps, using the same process.

When demand drops, such that the first pump speed falls below a minimum limit (user defined by a frequency limit), the PFA control automatically stops an auxiliary pump. The PFA control also increases the speed of the first pump to account for the auxiliary pump's missing output.

An Interlock function (when enabled) identifies off-line (out of service) motors, and the PFA control skips to the next available motor in the sequence.

An Autochange function (when enabled and with the appropriate switchgear) equalizes duty time between the pump motors. Autochange periodically increments the position of each motor in the rotation – the speed regulated motor becomes the last auxiliary motor, the first auxiliary motor becomes the speed regulated motor, etc.

When the speed regulated motor reaches the full output, it is disconnected from the drive and switched to direct on-line connection, with a slight delay in between.

Auxiliary motor 2 is connected to drive output. After a slight delay the motor speed is increased to fulfill the pumping capacity needed.

Auxiliary motors 3 and 4 are started according to the same routine.

The motor stopping routine always follows the normal PFA routine.

■ SPFC control

Soft pump and fan control (SPFC) is used for pump and fan alternation applications where lower pressure peaks are desirable when a new auxiliary motor is connected on-line. SPFC is an easy way to implement soft starting of direct on line (auxiliary) motors. The main difference between traditional PFC and SPFC is the way SPFC connects auxiliary motors on-line.

SPFC connects auxiliary motors online with a flying start, while the motor is still coasting. Thus, in some cases SPFC makes it possible to soften the start-up current while connecting auxiliary motors on-line. This is why lower pressure peaks on the pipelines and pumps may also be achieved. Connection sequence and powering routine of auxiliary motors in SPFC is explained more detailed in the diagram. The motor stopping routine follows always the normal PFC routine.

SPFC powering routine

The diagram below illustrates the SPFC powering routine.

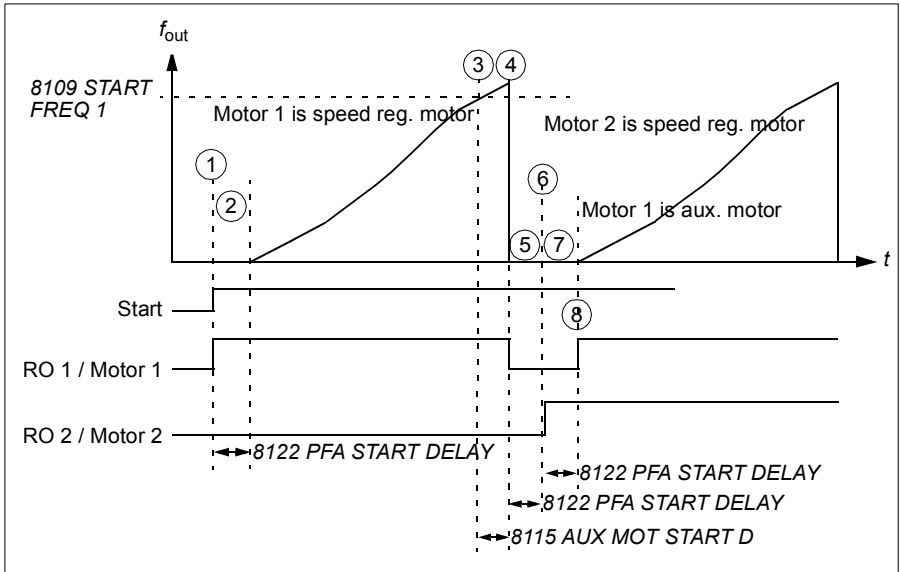

1. At start, relay RO 1 is closed and motor 1 is connected to the drive output.
2. The drive waits for the time specified by parameter *8122 PFA START DELAY* to ensure that the contactor (RO 1) has stabilized and then starts modulating from zero speed. Motor 1 is the speed regulated motor.
3. When the drive output frequency f_{out} rises over the start frequency (*8109 START FREQ 1*), the start delay for the auxiliary motor (*8115 AUX MOT START D*) is set.
4. When delay *8115* has elapsed, the drive coasts to stop and relay RO 1 is opened (motor 1 is disconnected from the drive output).
5. The drive waits for *8122 PFA START DELAY* to ensure that the contactor (RO 1) has stabilized.
6. After delay, *8122* RO 2 is closed and motor 2 is connected to the drive output as the new speed regulated motor.
7. The drive waits for *8122 PFA START DELAY* to ensure that the contactor (RO 2) has stabilized.
8. After delay *8122*, the drive starts modulating from zero speed regulating the speed of motor 2. RO 1 is closed and motor 1 is connected directly on-line as an auxiliary motor.

How to parameterize SPFC control

1. Set PFA reference steps (parameters [8103...8105](#)) if needed.
2. Set PFA start and stop frequencies (parameters [8109...8114](#)).
3. Set PFA auxiliary motor start and stop delays (parameters [8115...8116](#)).
4. Set the number of auxiliary motors (parameter [8117](#)).
5. Enable Autochange (parameter [8118](#)). In SPFC control, the parameter only allows SPFC to use PFA's alternation switchgear box. It is not used as the operating time interval between the automatic motor changes as in normal PFA application.
6. Autochange level is ignored (parameter [8119](#)).
7. Parameterize Interlocks (parameter [8120](#)).
8. Set Bypass function if needed (parameter [8121](#)).
9. Set PFA start delay (parameter [8122](#)).
10. Enable SPFC. Depending on the application, set parameter [8123 PFA ENABLE](#) to value 2 (SPFC ACTIVE – SPFC) or value 3 (SPFC + AUTOCHANGE).
 Value 1 (ACTIVE): enables normal PFA functionality.
 Value 2 (SPFC ACTIVE – SPFC): enables SPFC function with auxiliary motors running.
 Value 3 (SPFC + AUTOCHANGE): enables SPFC function only when auxiliary motors are not running
11. Set PFA acceleration and deceleration times if needed (parameters [8124...8125](#)).
12. Autochange enable with a timed function is ignored (parameter [8126](#)).
13. Set relays in [Group 14: Relay outputs](#). (Transistor output TO [parameter [1805 DO SIGNAL](#)] can be used as an additional relay output, if needed.) Both PFA and SPFC use these relays. You must set at least as many relays as there are motors set for SPFC (= the number of auxiliary motors [parameter [8117](#)] + 1 [speed regulated motor] when SPFC is used).
14. Set the number of PFA controlled motors in parameter [8127](#) (= number of PFC relays in [Group 14: Relay outputs](#)).
15. Also set other needed motor dependent parameters, eg [2007 MINIMUM FREQ](#), [2008 MAXIMUM FREQ](#) and [2605 U/F RATIO](#).

PFA control and SPFC control default settings have differences in acceleration time ([2202](#)), deceleration time ([2203](#)) and auxiliary motor stop delay ([8116](#)) parameters.

■ Settings

Parameter	Additional information
Group 14: Relay outputs	Selections of relay outputs for starting and stopping of motors
Group 18: Freq in & tran out	Selections of relay outputs for starting and stopping of motor (transistor output can be used as an additional relay)
Group 44: Pump protection	Pump protection (pressure monitoring) settings

Parameter	Additional information
<i>Group 81: PFA control; 8123 PFA ENABLE</i>	PFA control settings; Enables PFA/SPFC function.

■ Diagnostics

Actual signal	Additional information
<i>0116</i>	Application block output signal
<i>0162</i>	RO 1 status
<i>0163</i>	TO status
<i>0173</i>	RO 2...4 status. With option MREL-01 only.
Alarm	
<i>AUTOCHANGE</i>	PFA autochange function active
<i>PFC I LOCK</i>	PFA interlocks active
<i>INLET LOW, INLET VERY LOW</i>	Pressure at pump/fan inlet too low
<i>OUTLET HIGH, OUTLET VERY HIGH</i>	Pressure at pump/fan outlet too high
Fault	Additional information
<i>PAR PFC REF NEG</i>	<i>2007</i> < 0
<i>PAR PFA IO 1</i>	Not enough relays parameterized for the PFA control. Conflict between <i>Group 14: Relay outputs</i> , parameter <i>8117</i> and parameter <i>8118</i> .
<i>PAR PFC IO 2</i>	Parameter <i>8127</i> does not match the PFA motors in <i>Group 14: Relay outputs</i> and parameter <i>8118</i> .
<i>PAR PFC IO 3</i>	Allocation of a digital input (interlock) for each PFA motor not possible
<i>INLET LOW, INLET VERY LOW</i>	Pressure at pump/fan inlet too low
<i>OUTLET HIGH, OUTLET VERY HIGH</i>	Pressure at pump/fan outlet too high

■ Connection diagram example

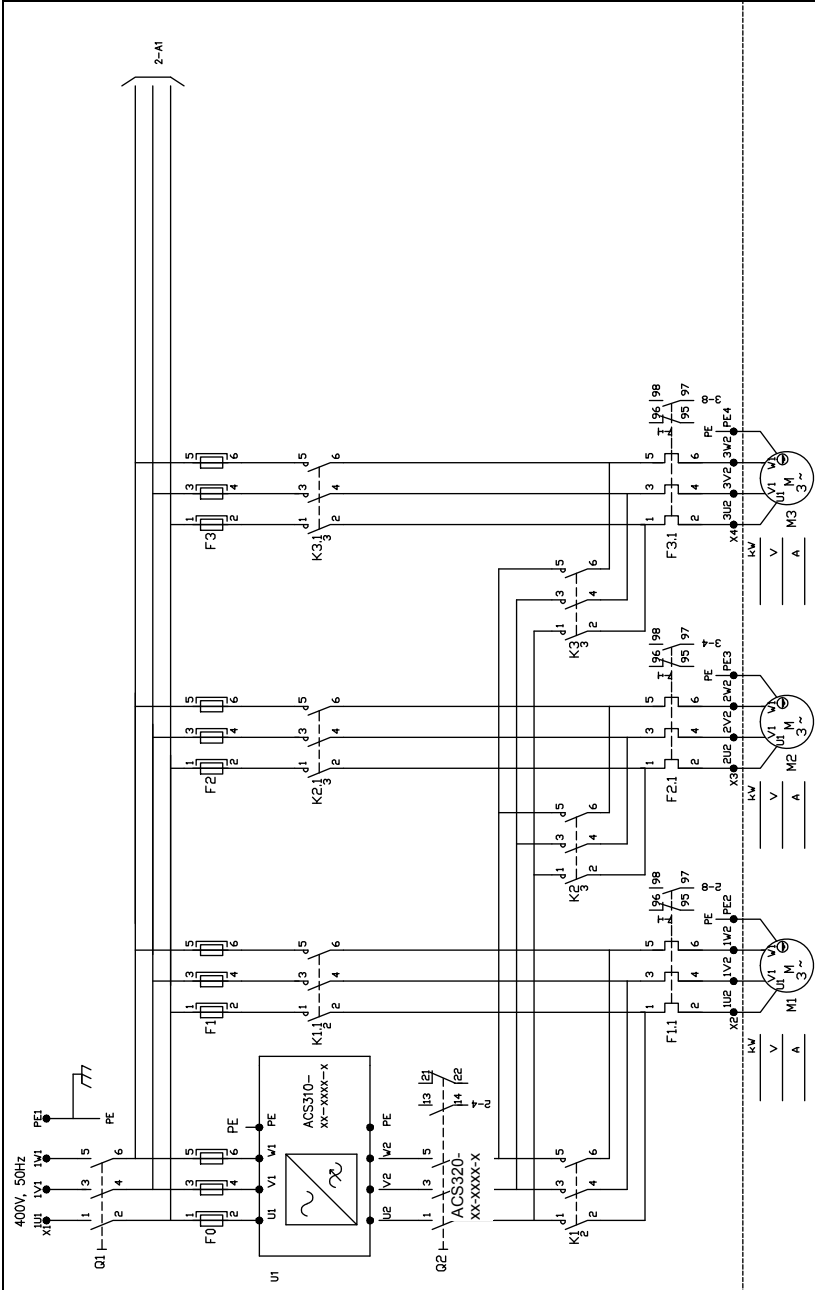



Actual signals and parameters

Contents of this chapter

The chapter describes the actual signals and parameters and gives the fieldbus equivalent values for each signal/parameter. It also contains a table of the default values for the different macros.

Note: When the control panel is in the short parameter view, in other words, when parameter [1611 PARAMETER VIEW](#) is set to 2 (SHORT VIEW), the control panel only shows a subset of all signals and parameters. The list of these signals and parameters starts on page [146](#).

To be able to view all actual signals and parameters, set parameter [1611 PARAMETER VIEW](#) to 3 (LONG VIEW). The descriptions of parameters start on pages [150](#).

Terms and abbreviations

Term	Definition
Actual signal	Signal measured or calculated by the drive. Can be monitored by the user. No user setting possible. Group 01: Operating data... Group 04: Fault history contain actual signals.
Def	Parameter default value
E	Refers to types 03E- with European parametrization
FbEq	Fieldbus equivalent: The scaling between the value and the integer used in serial communication.
Parameter	A user-adjustable operation instruction of the drive. Group 10: Start/Stop/Dir... Group 98: Options contain parameters. Note: Parameter selections are shown on the Basic Control Panel as integer values. For example, parameter 1001 EXT1 COMMANDS selection COMM is shown as value 10 (which is equal to the fieldbus equivalent FbEq).
U	Refers to types 03U- with US parametrization

Fieldbus equivalent

Example: If parameter [2008 MAXIMUM FREQ](#) (see page [193](#)) is set from an external control system, an integer value of 1 corresponds to 0.1 Hz. All the read and sent values are limited to 16 bits (-32768...32767).

Actual signals in the short parameter view

Actual signals in the short parameter view			
No.	Name/Value	Description	FbEq
04	FAULT HISTORY	Fault history (read-only). See Group 04: Fault history in the list of all parameters.	
0401	LAST FAULT	Code of the latest fault.	1 = 1

Parameters in the short parameter view

Parameters in the short parameter view			
No.	Name/Value	Description	Default
11	REFERENCE SELECT	Panel reference type, external control location selection and external reference sources and limits. See Group 11: Reference select in the list of all parameters.	
1105	REF1 MAX	Defines the maximum value for external reference REF1.	E: 50.0 Hz U: 60.0 Hz
12	CONSTANT SPEEDS	Constant speed (drive output frequency) selection and values. See Group 12: Constant speeds in the list of all parameters.	
1202	CONST SPEED 1	Defines constant drive output frequency 1.	E: 5.0 Hz U: 6.0 Hz
1203	CONST SPEED 2	Defines constant drive output frequency 2.	E: 10.0 Hz U: 12.0 Hz
1204	CONST SPEED 3	Defines constant drive output frequency 3.	E: 15.0 Hz U: 18.0 Hz
13	ANALOG INPUTS	Analog input signal processing. See Group 13: Analogue inputs in the list of all parameters.	
1301	MINIMUM AI1	Defines the minimum %-value that corresponds to minimum mA(V) signal for analog input AI1.	1.0%
14	RELAY OUTPUTS	Status information indicated through relay output, and relay operating delays. See Group 14: Relay outputs in the list of all parameters.	
1401	RELAY OUTPUT 1	Selects a drive status indicated through relay output RO 1.	FAULT(-1)
16	SYSTEM CONTROLS	Parameter view, Run Enable, parameter lock etc. See Group 16: System controls in the list of all parameters.	
1611	PARAMETER VIEW	Selects the parameter view, in other words, which parameters are shown on the control panel.	SHORT VIEW
20	LIMITS	Drive operation limits. See Group 20: Limits in the list of all parameters.	
2008	MAXIMUM FREQ	Defines the maximum limit for the drive output frequency.	E: 50.0 Hz U: 60.0 Hz
21	START/STOP	Start and stop modes of the motor. See Group 21: Start/Stop in the list of all parameters.	
2102	STOP FUNCTION	Selects the motor stop function.	COAST
22	ACCEL/DECEL	Acceleration and deceleration times. See Group 22: Accel/Decel in the list of all parameters.	
2202	ACCELER TIME 1	Defines the acceleration time 1.	5.0 s
2203	DECELER TIME 1	Defines the deceleration time 1.	5.0 s

Parameters in the short parameter view			
No.	Name/Value	Description	Default
53	EFB PROTOCOL	Embedded fieldbus link settings. See chapter <i>Fieldbus control</i> on page 285.	
5301	EFB PROTOCOL ID	Contains the identification and program version of the protocol. Note: You can reset this parameter only with parameter <i>9802 COMM PROT SEL.</i>	-
5302	EFB STATION ID	Defines the address of the device. Two units with the same address are not allowed on-line.	1
5303	EFB BAUD RATE	Defines the transfer rate of the link	9.6 kbit/s
5304	EFB PARITY	Defines the use of parity and stop bit(s) and the data length. The same setting must be used in all on-line stations.	8 NONE 1
5305	EFB CTRL PROFILE	Selects the communication profile. See section <i>Communication profiles</i> on page 339.	
5306	EFB OK MESSAGES	Number of valid messages received by the drive. During normal operation, this number increases constantly.	0
5307	EFB CRC ERRORS	Number of messages with an CRC (cyclic redundancy check) error received by the drive. If the number is high, check CRC calculation for possible errors. Note: High electromagnetic noise levels generate errors.	0
5308	EFB UART ERRORS	Number of messages with a character error received by the drive.	0
5309	EFB STATUS	Status of the EFB protocol.	IDLE
5310	EFB PAR 10	Selects an actual value to be mapped to Modbus register 40005.	0
5311	EFB PAR 11	Selects an actual value to be mapped to Modbus register 40006.	0
5312	EFB PAR 12	Selects an actual value to be mapped to Modbus register 40007.	0
5313	EFB PAR 13	Selects an actual value to be mapped to Modbus register 40008.	0
5314	EFB PAR 14	Selects an actual value to be mapped to Modbus register 40009.	0
5315	EFB PAR 15	Selects an actual value to be mapped to Modbus register 40010.	0
5316	EFB PAR 16	Selects an actual value to be mapped to Modbus register 40011.	0
5317	EFB PAR 17	Selects an actual value to be mapped to Modbus register 40012.	0
5318	EFB PAR 18	For Modbus: Sets an additional delay before the drive begins transmitting response to the master request.	0
5319	EFB PAR 19	ABB drives profile (ABB DRV LIM or ABB DRV FULL) Control word. Read only copy of the Fieldbus Control word.	0000 hex

Parameters in the short parameter view			
No.	Name/Value	Description	Default
5320	EFB PAR 20	ABB drives profile (ABB DRV LIM or ABB DRV FULL) Status word. Read only copy of the Fieldbus Status word.	0000 hex
98 OPTIONS		External serial communication activation.	
9802	COMM PROT SEL	Activates the external serial communication and selects the interface.	NOT SEL
99 START-UP DATA		Language selection. Definition of motor set-up data. See Group 99: Start-up data in the list of all parameters.	
9901	LANGUAGE	Selects the display language.	ENGLISH
9902	APPLIC MACRO	Selects the application macro.	HVAC DEFAULT
9905	MOTOR NOM VOLT	Defines the nominal motor voltage.	230 V (200 V units) 400 V (400 V E units) 460 V (400 V U units)
9906	MOTOR NOM CURR	Defines the nominal motor current.	I_{2N}
9907	MOTOR NOM FREQ	Defines the nominal motor frequency.	E: 50.0 Hz U: 60.0 Hz
9908	MOTOR NOM SPEED	Defines the nominal motor speed.	Type dependent
9909	MOTOR NOM POWER	Defines the nominal motor power.	P_N

Parameter listing

Parameter data is specific to ACS320 firmware version 4.01C.

■ Group 99: Start-up data

This group defines special Start-up data required to:

- set up the drive
- enter motor information.

Note: Parameters checked under the heading “S” can be modified only when the drive is stopped.

Group 99: Start-up data					
Code	Description	Range	Resolution	Default	S
9901	LANGUAGE Selects the display language. 0= ENGLISH 1= ENGLISH (AM) 2= DEUTSCH 3= ITALIANO 4= ESPAÑOL 5= PORTUGUES 6= NEDERLANDS 7= FRANCAIS 8= DANSK 9= SUOMI 10= SVENSKA 11= RUSSKI 12= POLSKI 13= TÜRKCE 14= CZECH 15= MAGYAR 16= ELLINIKA 17= CHINESE 18= KOREAN 19= JAPANESE	0...25	1	0	
9902	APPLIC MACRO Selects an application macro. Application macros automatically edit parameters to configure the ACS320 for a particular application. See Application macros for application macro descriptions. 1= HVAC DEFAULT 2= SUPPLY FAN 3= RETURN FAN 4= CLNG TWR FAN 5= CONDENSER 6= BOOSTER PUMP 7= PUMP ALTERNA 8= INT TIMER 9= INT TIMER CS 10= FLOATING PNT 11= DUAL SETPPID 12= DL SP PID CS 13= E -BYPASS 14= HAND CONTROL 15= E-CLIPSE 21= AC500 MODBUS	-3...21	1	1	✓
9905	MOTOR NOM VOLT Defines the nominal motor voltage. • Must equal the value on the motor rating plate. • Sets the maximum drive output voltage supplied to the motor. • Drive cannot supply the motor with a voltage greater than the mains voltage.	115 ... 345 V (200 V, US) 230 ... 690 V (400 V, US) 288 ... 862 V (600 V, US)	1 V 1 V 1 V	230 V 460 V 575 V	✓
9906	MOTOR NOM CURR Defines the nominal motor current. • Must equal the value on the motor rating plate.	0.15*I _{2N} ... 1.5*I _{2N}	0.1 A	1.5*I _{2N}	✓

Group 99: Start-up data					
Code	Description	Range	Resolution	Default	S
9907	MOTOR NOM FREQ Defines the nominal motor frequency. <ul style="list-style-type: none"> Range: 10 ... 500 Hz (typically 50 or 60 Hz) Sets the frequency at which output voltage equals parameter 9905 MOTOR NOM VOLT Field weakening point = Norm freq * Supply Volt / Mot Nom Volt 	10.0 ... 500 Hz	0.1 Hz	60 Hz (US)	✓
9908	MOTOR NOM SPEED Defines the nominal motor speed. <ul style="list-style-type: none"> Must equal the value on the motor rating plate. 	50 ... 30000 rpm	1 rpm	Size dependent	✓
9909	MOTOR NOM POWER Defines the nominal motor power. <ul style="list-style-type: none"> Must equal the value on the motor rating plate. 	0.15 ... 1.5*P _N	0.1 Hp	0.2 HP (US)	✓
9914	PHASE INVERSION Inverts two phases in the motor cable. This changes the direction of the motor rotation without having to exchange the positions of two motor cable phase conductors at the drive output terminals or at the motor connection box. <ul style="list-style-type: none"> NO – Phases not inverted. YES – Phases inverted. 			NO	✓

■ Group 01: Operating data

This group contains drive operating data, including actual signals. The drive sets the values for actual signals, based on measurements or calculations. You cannot set these values.

Group 01: Operating data					
Code	Description	Range	Resolution	Default	S
0101	SPEED & DIR The calculated speed of the motor (rpm) & motor direction.	-30000...30000	1 rpm	-	
0102	SPEED The calculated speed of the motor (rpm).	0 ... 30000 rpm	1 rpm	-	
0103	OUTPUT FREQ The frequency (Hz) applied to the motor. (Also shown by default in OUTPUT display.)	0.0 ... 500.0 Hz	1Hz	-	
0104	CURRENT The motor current, as measured by the drive. (Also shown by default in OUTPUT display.)	0.0 ... 1.5*I _{2N}	0.1 A	-	
0105	TORQUE Output torque. Calculated value of torque on motor shaft in % of motor nominal torque.	-200% ... 200%	0.1%	-	
0106	POWER The measured motor power in kW.	-1.5 ... 1.5*P _N	0.1 kW	-	
0107	DC BUS VOLTAGE The DC bus voltage in VDC, as measured by the drive.	0 V ... 2.5*V _{dN}	1 V	-	
0109	OUTPUT VOLTAGE The voltage applied to the motor.	0 V ... 2.0*V _{dN}	1 V	-	
0110	DRIVE TEMP The temperature of the drive power transistors in Celsius.	0°C ... 150°C	1°C	-	
0111	EXTERNAL REF 1 External reference, REF1 or Hz.	0 ... 500 Hz	0.1 Hz	-	
0112	EXTERNAL REF 2 External reference, REF2, in % (torque: 0% ... 600%)	0% ... 100%	0.1%	-	
0113	CTRL LOCATION Active control location. Alternatives are: 0 = HAND 1 = EXT1 2 = EXT2	0 ... 2	1	-	
0114	RUN TIME (R) The drive's accumulated running time in hours (h). • Can be reset by pressing UP and DOWN buttons simultaneously when in parameter set mode.	0 ... 10000 h	1 h	0 h	

Group 01: Operating data					
Code	Description	Range	Resolution	Default	S
0115	KWH COUNTER (R) The drive's accumulated power consumption in kilowatt hours. • Can be reset by pressing UP and DOWN buttons simultaneously when in parameter set mode.	0 ... 10000 h	1 h	-	
0116	APPL BLK OUTPUT Application block output signal. Value is from either: • PFA control, if PFA Control is active, or • Parameter 0112 EXTERNAL REF 2 .	0 ... 100% (torque: 0 ... 600%)	0.1%	-	
0120	AI1 Relative value of analog input 1 in %.	-100 ... 100%	0.1%	-	
0121	AI2 Relative value of analog input 2 in %.	-100 ... 100%	0.1%	-	
0124	AO1 The analog output 1 value in milliamperes.	0 ... 20 mA	0.1 mA	-	
0126	PID 1 OUTPUT The PID Controller 1 output value in %.	0 ... 100%	0.1%	-	
0127	PID 2 OUTPUT The PID Controller 2 output value in %.	0 ... 100%	0.1%	-	
0128	PID 1 SETPNT The PID 1 controller setpoint signal. • Units and scale defined by PID parameters 4006/4106 & 4007/4107 .	-	-	-	
0129	PID 2 SETPNT The PID 2 controller setpoint signal. • Units and scale defined by PID parameters 4206 & 4207 .	-	-	-	
0130	PID 1 FBK The PID 1 controller feedback signal. • Units and scale defined by PID parameters 4006/4106 & 4007/4107 .	-	-	-	
0131	PID 2 FBK The PID 2 controller feedback signal. • Units and scale defined by PID parameters 4206 & 4207 .	-	-	-	
0132	PID 1 DEVIATION The difference between the PID 1 controller reference value and actual value. • Units and scale defined by PID parameters 4006/4106 & 4007/4107 .	-	-	-	
0133	PID 2 DEVIATION The difference between the PID 2 controller reference value and actual value. • Units and scale defined by PID parameters 4206 & 4207 .	-	-	-	

Group 01: Operating data					
Code	Description	Range	Resolution	Default	S
0134	COMM RO WORD Free data location that can be written from serial link. • Used for relay output control. • See parameter 1401.	0...65535	1	0	
0135	COMM VALUE 1 Free data location that can be written from serial link.	-32768 ... +32767	1	0	
0136	COMM VALUE 2 Free data location that can be written from serial link.	-32768 ... +32767	1	0	
0137	PROCESS VAR 1 Process variable 1 • Defined by parameters in Group 34: Panel display .	-	1		
0138	PROCESS VAR 2 Process variable 2 • Defined by parameters in Group 34: Panel display .	-	1		
0139	PROCESS VAR 3 Process variable 3 • Defined by parameters in Group 34: Panel display .	-	1		
0140	RUN TIME The drive's accumulated running time in thousands of hours (kh). Cannot be reset.	0 ... 499.99 kh	0.01 kh	0 kh	
0141	MWH COUNTER The drive's accumulated power consumption in megawatt hours. Cannot be reset	0 ... 65535 MWh	1 MWh	-	
0142	REVOLUTION CNTR The motor's accumulated revolutions in millions of revolutions. Can be reset by pressing the UP and DOWN keys simultaneously when in the Parameters mode.	0 ... 65535 Mrev	1	0	
0143	DRIVE ON TIME HI The drive's accumulated power-on-time in days. Cannot be reset.	0 ... 65535 days	1 day	0	
0144	DRIVE ON TIME LO The drive's accumulated power-on-time in 2 second ticks (30 ticks = 60 seconds). • Shown in format hh.mm.ss. • Cannot be reset.	00.00.00 ... 23:59:58	2 s	0	
0145	MOTOR TEMP Motor temperature in Celsius / PTC resistance in Ohms. • Applies only if motor temperature sensor is set up. See parameter 3501 SENSOR TYPE .	-10...200 °C/ 0...5000 Ohm / 0...1	1	0	
0158	PID COMM VALUE 1 Data received from fieldbus for PID control (PID1 and PID2).				

Group 01: Operating data					
Code	Description	Range	Resolution	Default	S
0159	PID COMM VALUE 2 Data received from fieldbus for PID control (PID1 and PID2).				
0160	DI 1-5 STATUS Status of digital inputs. Example: 10000 = DI1 is on, DI2...DI5 are off.				
0161	PULSE INPUT FREQ Value of frequency input in Hz.		1 = 1 Hz		
0162	RO STATUS Status of relay output 1.1 = RO is energized, 0 = RO is de-energized.		1 = 1		
0163	TO STATUS Status of transistor output when transistor output is used as a digital output.		1 = 1		
0164	TO FREQUENCY Transistor output frequency, when transistor output is used as a frequency output.		1 = 1 Hz		
0173	RO 2-4 STATUS Status of the relays in the Relay Output Extension Module MREL-0. See <i>MREL-01 Relay Output Extension Module User's Manual</i> (3AUA0000035974 [English]). Example: 100 = RO 2 is on, RO3 and RO 4 are off.				
0174	SAVED KWH Energy saved in kWh compared to the energy used when the load is connected directly to the supply. See the note on page 253. <ul style="list-style-type: none"> The counter value is accumulated till it reaches 999.9 after which the counter rolls over and starts again from 0.0. Can be reset with parameter 4509 ENERGY RESET (resets all energy calculators at the same time). See group Group 45: Energy saving. 	0.0 ... 999.9 kWh			
0175	SAVED MWH Energy saved in MWh compared to the energy used when the load is connected directly to the supply. See the note on page 253. <ul style="list-style-type: none"> The counter value is accumulated till it reaches 65535 after which the counter rolls over and starts again from 0. Can be reset with parameter 4509 ENERGY RESET (resets all energy calculators at the same time). See group Group 45: Energy saving. 	0 ... 65535 MWh			

Group 01: Operating data					
Code	Description	Range	Resolution	Default	S
0176	<p>SAVED AMOUNT 1</p> <p>Energy saved in local currency (remainder when the total saved energy is divided by 1000). See the note on page 253.</p> <ul style="list-style-type: none"> To find out the total saved energy in currency units, add the value of parameter 0177 SAVED AMOUNT 2 multiplied by 1000 to the value of parameter 0176. <p>Example: 0176 SAVED AMOUNT 1 = 123.4 0177 SAVED AMOUNT 2 = 5 Total saved energy = 5 * 1000 + 123.4 = 5123.4 currency units.</p> <ul style="list-style-type: none"> The counter value is accumulated till it reaches 999.9 (the counter does not roll over). Can be reset with parameter 4509 ENERGY RESET (resets all energy calculators at the same time). Local energy price is set with parameter 4502 ENERGY PRICE. See group Group 45: Energy saving. 	0.0 ... 999.9			
0177	<p>SAVED AMOUNT 2</p> <p>Energy saved in local currency in thousand currency units. For example, value 5 means 5000 currency units. See the note on page 253.</p> <ul style="list-style-type: none"> The counter value is accumulated till it reaches 65535 (the counter does not roll over). See parameter 0176 SAVED AMOUNT 1. 	0...65535			
0178	<p>SAVED CO2</p> <p>Reduction on carbon dioxide emissions in tn. See the note on page 253.</p> <ul style="list-style-type: none"> The counter value is accumulated till it reaches 6553.5 (the counter does not roll over). Can be reset with parameter 4509 ENERGY RESET (resets all energy calculators at the same time). CO2 conversion factor is set with parameter 4507 CO2 CONV FACTOR. See group Group 45: Energy saving. 	0 ... 6553.5 tn			

■ Group 03: FB actual signals

This group monitors fieldbus communications.

Group 03: FB actual signals																																																							
Code	Description	Range	Resolution	Default	S																																																		
0301	FB CMD WORD 1 Read-only copy of the Fieldbus command word 1. <ul style="list-style-type: none"> The fieldbus command is the principal means for controlling the drive from a fieldbus controller. The command consists of two Command words. Bit-coded instructions in the Command words switch the drive between states. To control the drive, using the Command words, an external location (EXT1 or EXT2) must be active and set to COMM. (See parameters 1001 EXT1 COMMANDS and 1002 EXT2 COMMANDS.) The control panel displays the word in hex. For example, all zeros and a 1 in Bit 0 displays as 0001. All zeros and a 1 in Bit 15 displays as 8000. 	-	-	-																																																			
	<table border="1"> <thead> <tr> <th>Bit #</th> <th>0301 FB CMD WORD 1</th> <th>0302 FB CMD WORD 2</th> </tr> </thead> <tbody> <tr><td>0</td><td>STOP</td><td>FBLOCAL_CTL</td></tr> <tr><td>1</td><td>START</td><td>FBLOCAL_REF</td></tr> <tr><td>2</td><td>REVERSE</td><td>START_DISABLE1</td></tr> <tr><td>3</td><td>LOCAL</td><td>START_DISABLE2</td></tr> <tr><td>4</td><td>RESET</td><td>Reserved</td></tr> <tr><td>5</td><td>EXT2</td><td>Reserved</td></tr> <tr><td>6</td><td>RUN_DISABLE</td><td>MOTOR_HEAT</td></tr> <tr><td>7</td><td>STPMODE_R</td><td>Reserved</td></tr> <tr><td>8</td><td>STPMODE_EM</td><td>Reserved</td></tr> <tr><td>9</td><td>STPMODE_C</td><td>Reserved</td></tr> <tr><td>10</td><td>RAMP_2</td><td>Reserved</td></tr> <tr><td>11</td><td>RAMP_OUT_0</td><td>REF_CONST</td></tr> <tr><td>12</td><td>RAMP_HOLD</td><td>REF_AVE</td></tr> <tr><td>13</td><td>RAMP_IN_0</td><td>LINK_ON</td></tr> <tr><td>14</td><td>REQ_LOCALLOC</td><td>REQ_STARTINH</td></tr> <tr><td>15</td><td>Reserved</td><td>OFF_INTERLOCK</td></tr> </tbody> </table>	Bit #	0301 FB CMD WORD 1	0302 FB CMD WORD 2	0	STOP	FBLOCAL_CTL	1	START	FBLOCAL_REF	2	REVERSE	START_DISABLE1	3	LOCAL	START_DISABLE2	4	RESET	Reserved	5	EXT2	Reserved	6	RUN_DISABLE	MOTOR_HEAT	7	STPMODE_R	Reserved	8	STPMODE_EM	Reserved	9	STPMODE_C	Reserved	10	RAMP_2	Reserved	11	RAMP_OUT_0	REF_CONST	12	RAMP_HOLD	REF_AVE	13	RAMP_IN_0	LINK_ON	14	REQ_LOCALLOC	REQ_STARTINH	15	Reserved	OFF_INTERLOCK			
Bit #	0301 FB CMD WORD 1	0302 FB CMD WORD 2																																																					
0	STOP	FBLOCAL_CTL																																																					
1	START	FBLOCAL_REF																																																					
2	REVERSE	START_DISABLE1																																																					
3	LOCAL	START_DISABLE2																																																					
4	RESET	Reserved																																																					
5	EXT2	Reserved																																																					
6	RUN_DISABLE	MOTOR_HEAT																																																					
7	STPMODE_R	Reserved																																																					
8	STPMODE_EM	Reserved																																																					
9	STPMODE_C	Reserved																																																					
10	RAMP_2	Reserved																																																					
11	RAMP_OUT_0	REF_CONST																																																					
12	RAMP_HOLD	REF_AVE																																																					
13	RAMP_IN_0	LINK_ON																																																					
14	REQ_LOCALLOC	REQ_STARTINH																																																					
15	Reserved	OFF_INTERLOCK																																																					
0302	FB CMD WORD 2 Read-only copy of the Fieldbus command word 2. <ul style="list-style-type: none"> See parameter 0301 FB CMD WORD 1. 	-	-	-																																																			

Group 03: FB actual signals

Code	Description	Range	Resolution	Default	S																																																			
0303	FB STS WORD 1 Read-only copy of the Status word 1. <ul style="list-style-type: none"> The drive sends status information to the fieldbus controller. The status consists of two Status words. <table border="1"> <thead> <tr> <th>Bit #</th> <th>0303 STS CMD WORD 1</th> <th>0304 FB STS WORD 2</th> </tr> </thead> <tbody> <tr><td>0</td><td>READY</td><td>ALARM</td></tr> <tr><td>1</td><td>ENABLED</td><td>REQ_MAINT</td></tr> <tr><td>2</td><td>STARTED</td><td>DIRLOCK</td></tr> <tr><td>3</td><td>RUNNING</td><td>LOCALLOCK</td></tr> <tr><td>4</td><td>ZERO_SPEED</td><td>CTL_MODE</td></tr> <tr><td>5</td><td>ACCELERATE</td><td>Reserved</td></tr> <tr><td>6</td><td>DECELERATE</td><td>MOTORHEAT</td></tr> <tr><td>7</td><td>AT_SETPOINT</td><td>Reserved</td></tr> <tr><td>8</td><td>LIMIT</td><td>Reserved</td></tr> <tr><td>9</td><td>SUPERVISION</td><td>Reserved</td></tr> <tr><td>10</td><td>REV_REF</td><td>REQ_CTL</td></tr> <tr><td>11</td><td>REV_ACT</td><td>REQ_REF1</td></tr> <tr><td>12</td><td>PANEL_LOCAL</td><td>REQ_REF2</td></tr> <tr><td>13</td><td>FIELDBUS_LOCAL</td><td>REQ_REF2EXT</td></tr> <tr><td>14</td><td>EXT2_ACT</td><td>ACK_STARTINH</td></tr> <tr><td>15</td><td>FAULT</td><td>ACK_OFF_ILCK</td></tr> </tbody> </table>	Bit #	0303 STS CMD WORD 1	0304 FB STS WORD 2	0	READY	ALARM	1	ENABLED	REQ_MAINT	2	STARTED	DIRLOCK	3	RUNNING	LOCALLOCK	4	ZERO_SPEED	CTL_MODE	5	ACCELERATE	Reserved	6	DECELERATE	MOTORHEAT	7	AT_SETPOINT	Reserved	8	LIMIT	Reserved	9	SUPERVISION	Reserved	10	REV_REF	REQ_CTL	11	REV_ACT	REQ_REF1	12	PANEL_LOCAL	REQ_REF2	13	FIELDBUS_LOCAL	REQ_REF2EXT	14	EXT2_ACT	ACK_STARTINH	15	FAULT	ACK_OFF_ILCK	-	1	- hex	
Bit #	0303 STS CMD WORD 1	0304 FB STS WORD 2																																																						
0	READY	ALARM																																																						
1	ENABLED	REQ_MAINT																																																						
2	STARTED	DIRLOCK																																																						
3	RUNNING	LOCALLOCK																																																						
4	ZERO_SPEED	CTL_MODE																																																						
5	ACCELERATE	Reserved																																																						
6	DECELERATE	MOTORHEAT																																																						
7	AT_SETPOINT	Reserved																																																						
8	LIMIT	Reserved																																																						
9	SUPERVISION	Reserved																																																						
10	REV_REF	REQ_CTL																																																						
11	REV_ACT	REQ_REF1																																																						
12	PANEL_LOCAL	REQ_REF2																																																						
13	FIELDBUS_LOCAL	REQ_REF2EXT																																																						
14	EXT2_ACT	ACK_STARTINH																																																						
15	FAULT	ACK_OFF_ILCK																																																						
0304	FB STS WORD 2 Read-only copy of the Status word 2. <ul style="list-style-type: none"> See parameter 0303 FB STS WORD 1. 	-	1	- hex																																																				

Group 03: FB actual signals																																																																								
Code	Description	Range	Resolution	Default	S																																																																			
0305	FAULT WORD 1 Read-only copy of the Fault word 1. <ul style="list-style-type: none"> When a fault is active, the corresponding bit for the active fault is set in the Fault words. Each fault has a dedicated bit allocated within Fault words. See chapter Fault tracing on page 361 for a description of the faults. The control panel displays the word in hex. For example, all zeros and a 1 in Bit 0 displays a 0001. All zeros and a 1 in Bit 15 displays as 8000.	-	1	0000 hex																																																																				
	<table border="1"> <thead> <tr> <th>Bit #</th> <th>0305 FAULT WORD 1</th> <th>0306 FAULT WORD 2</th> <th>0307 FAULT WORD 3</th> </tr> </thead> <tbody> <tr><td>0</td><td>OVERCURRENT</td><td>Reserved</td><td>EFB 1</td></tr> <tr><td>1</td><td>DC OVERVOLT</td><td>THERM FAIL</td><td>EFB 2</td></tr> <tr><td>2</td><td>DEV OVERTEMP</td><td>Reserved</td><td>EFB 3</td></tr> <tr><td>3</td><td>SHORT CIRC</td><td>Reserved</td><td>INCOMPATIBLE SW</td></tr> <tr><td>4</td><td>Reserved</td><td>CURR MEAS</td><td>USER LOAD CURVE</td></tr> <tr><td>5</td><td>DC UNDERVOLT</td><td>SUPPLY PHASE</td><td>UNKNOWN EXTENSION</td></tr> <tr><td>6</td><td>AI1 LOSS</td><td>Reserved</td><td>INLET VERY LOW</td></tr> <tr><td>7</td><td>AI2 LOSS</td><td>OVERSPEED</td><td>OUTLET VERY HIGH</td></tr> <tr><td>8</td><td>MOT OVERTEMP</td><td>Reserved</td><td>INLET LOW</td></tr> <tr><td>9</td><td>PANEL LOSS</td><td>DRIVE ID</td><td>OUTLET HIGH</td></tr> <tr><td>10</td><td>Reserved</td><td>CONFIG FILE</td><td>System error</td></tr> <tr><td>11</td><td>MOTOR STALL</td><td>SERIAL 1 ERR</td><td>System error</td></tr> <tr><td>12</td><td>Reserved</td><td>EFB CON FILE</td><td>System error</td></tr> <tr><td>13</td><td>EXT FLT 1</td><td>FORCE TRIP</td><td>System error</td></tr> <tr><td>14</td><td>EXT FLT 2</td><td>MOTOR PHASE</td><td>System error</td></tr> <tr><td>15</td><td>EARTH FAULT</td><td>OUTP WIRING</td><td>Parameter setting fault</td></tr> </tbody> </table>	Bit #	0305 FAULT WORD 1	0306 FAULT WORD 2	0307 FAULT WORD 3	0	OVERCURRENT	Reserved	EFB 1	1	DC OVERVOLT	THERM FAIL	EFB 2	2	DEV OVERTEMP	Reserved	EFB 3	3	SHORT CIRC	Reserved	INCOMPATIBLE SW	4	Reserved	CURR MEAS	USER LOAD CURVE	5	DC UNDERVOLT	SUPPLY PHASE	UNKNOWN EXTENSION	6	AI1 LOSS	Reserved	INLET VERY LOW	7	AI2 LOSS	OVERSPEED	OUTLET VERY HIGH	8	MOT OVERTEMP	Reserved	INLET LOW	9	PANEL LOSS	DRIVE ID	OUTLET HIGH	10	Reserved	CONFIG FILE	System error	11	MOTOR STALL	SERIAL 1 ERR	System error	12	Reserved	EFB CON FILE	System error	13	EXT FLT 1	FORCE TRIP	System error	14	EXT FLT 2	MOTOR PHASE	System error	15	EARTH FAULT	OUTP WIRING	Parameter setting fault			
Bit #	0305 FAULT WORD 1	0306 FAULT WORD 2	0307 FAULT WORD 3																																																																					
0	OVERCURRENT	Reserved	EFB 1																																																																					
1	DC OVERVOLT	THERM FAIL	EFB 2																																																																					
2	DEV OVERTEMP	Reserved	EFB 3																																																																					
3	SHORT CIRC	Reserved	INCOMPATIBLE SW																																																																					
4	Reserved	CURR MEAS	USER LOAD CURVE																																																																					
5	DC UNDERVOLT	SUPPLY PHASE	UNKNOWN EXTENSION																																																																					
6	AI1 LOSS	Reserved	INLET VERY LOW																																																																					
7	AI2 LOSS	OVERSPEED	OUTLET VERY HIGH																																																																					
8	MOT OVERTEMP	Reserved	INLET LOW																																																																					
9	PANEL LOSS	DRIVE ID	OUTLET HIGH																																																																					
10	Reserved	CONFIG FILE	System error																																																																					
11	MOTOR STALL	SERIAL 1 ERR	System error																																																																					
12	Reserved	EFB CON FILE	System error																																																																					
13	EXT FLT 1	FORCE TRIP	System error																																																																					
14	EXT FLT 2	MOTOR PHASE	System error																																																																					
15	EARTH FAULT	OUTP WIRING	Parameter setting fault																																																																					
0306	FAULT WORD 2 A16-bit data word. For the possible causes and remedies and fieldbus equivalents, see chapter Fault tracing on page 361. See parameter 0305 FAULT WORD 1 .	-	1	0000 hex																																																																				
0307	FAULT WORD 3 A16-bit data word. For the possible causes and remedies and fieldbus equivalents, see chapter Fault tracing on page 361. See parameter 0305 FAULT WORD 1 .	-	1	0000 hex																																																																				

Group 03: FB actual signals

Code	Description	Range	Resolution	Default	S																																																		
0308	ALARM WORD 1 Read-only copy of the ALARM WORD 1. <ul style="list-style-type: none"> When a fault is active, the corresponding bit for the active fault is set in the Fault words. Each fault has a dedicated bit allocated within Fault words. Bits remain set until the whole alarm word is reset. (Reset by writing zero to the word). The control panel displays the word in hex. For example, all zeros and a 1 in Bit 0 correspond to 0001. All zeros and a 1 in Bit 15 correspond to 80000. 	-	1	0000 hex																																																			
	<table border="1"> <thead> <tr> <th>Bit #</th> <th>0308 ALARM WORD 1</th> <th>0309 ALARM WORD 2</th> </tr> </thead> <tbody> <tr><td>0</td><td>OVERCURRENT</td><td>OFF BUTTON</td></tr> <tr><td>1</td><td>OVERVOLTAGE</td><td>PID SLEEP</td></tr> <tr><td>2</td><td>UNDERVOLTAGE</td><td>Reserved</td></tr> <tr><td>3</td><td>DIRLOCK</td><td>OVERRIDE</td></tr> <tr><td>4</td><td>I/O COMM</td><td>START ENABLE 1 MISSING</td></tr> <tr><td>5</td><td>AI1 LOSS</td><td>START ENABLE 2 MISSING</td></tr> <tr><td>6</td><td>AI2 LOSS</td><td>EMERGENCY STOP</td></tr> <tr><td>7</td><td>PANEL LOSS</td><td>Reserved</td></tr> <tr><td>8</td><td>DEVICE OVERTEMP</td><td>FIRST START</td></tr> <tr><td>9</td><td>MOT OVERTEMP</td><td>Reserved</td></tr> <tr><td>10</td><td>UNDERLOAD</td><td>USER LOAD CURVE</td></tr> <tr><td>11</td><td>MOTOR STALL</td><td>START DELAY</td></tr> <tr><td>12</td><td>AUTORESET</td><td>Reserved</td></tr> <tr><td>13</td><td>PFA AUTOCHANGE</td><td>INLET LOW</td></tr> <tr><td>14</td><td>PFA INTERLOCK</td><td>INLET HIGH</td></tr> <tr><td>15</td><td>Reserved</td><td>PIPE FILL</td></tr> </tbody> </table>	Bit #	0308 ALARM WORD 1	0309 ALARM WORD 2	0	OVERCURRENT	OFF BUTTON	1	OVERVOLTAGE	PID SLEEP	2	UNDERVOLTAGE	Reserved	3	DIRLOCK	OVERRIDE	4	I/O COMM	START ENABLE 1 MISSING	5	AI1 LOSS	START ENABLE 2 MISSING	6	AI2 LOSS	EMERGENCY STOP	7	PANEL LOSS	Reserved	8	DEVICE OVERTEMP	FIRST START	9	MOT OVERTEMP	Reserved	10	UNDERLOAD	USER LOAD CURVE	11	MOTOR STALL	START DELAY	12	AUTORESET	Reserved	13	PFA AUTOCHANGE	INLET LOW	14	PFA INTERLOCK	INLET HIGH	15	Reserved	PIPE FILL			
Bit #	0308 ALARM WORD 1	0309 ALARM WORD 2																																																					
0	OVERCURRENT	OFF BUTTON																																																					
1	OVERVOLTAGE	PID SLEEP																																																					
2	UNDERVOLTAGE	Reserved																																																					
3	DIRLOCK	OVERRIDE																																																					
4	I/O COMM	START ENABLE 1 MISSING																																																					
5	AI1 LOSS	START ENABLE 2 MISSING																																																					
6	AI2 LOSS	EMERGENCY STOP																																																					
7	PANEL LOSS	Reserved																																																					
8	DEVICE OVERTEMP	FIRST START																																																					
9	MOT OVERTEMP	Reserved																																																					
10	UNDERLOAD	USER LOAD CURVE																																																					
11	MOTOR STALL	START DELAY																																																					
12	AUTORESET	Reserved																																																					
13	PFA AUTOCHANGE	INLET LOW																																																					
14	PFA INTERLOCK	INLET HIGH																																																					
15	Reserved	PIPE FILL																																																					
0309	ALARM WORD 2 Read-only copy of the ALARM WORD 3. <ul style="list-style-type: none"> See parameter 0308 ALARM WORD 1. 	-	1	0000 hex																																																			
0310	ALARM WORD 3 A 16-bit data word. For the possible causes and remedies and fieldbus equivalents, see chapter Fault tracing on page 361 . An alarm can be reset by resetting the whole alarm word: Write zero to the word.	-	1	0000 hex																																																			
	<table border="1"> <thead> <tr> <th>Bit #</th> <th></th> </tr> </thead> <tbody> <tr><td>0</td><td>INLET VERY LOW</td></tr> <tr><td>1</td><td>OUTLET VERY HIGH</td></tr> <tr><td>2...15</td><td>Reserved</td></tr> </tbody> </table>	Bit #		0	INLET VERY LOW	1	OUTLET VERY HIGH	2...15	Reserved																																														
Bit #																																																							
0	INLET VERY LOW																																																						
1	OUTLET VERY HIGH																																																						
2...15	Reserved																																																						

■ Group 04: Fault history

This group stores a recent history of the faults reported by the drive.

Group 04: Fault history					
Code	Description	Range	Resolution	Default	S
0401	LAST FAULT 0 = Clear the fault history (on panel = NO RECORD). n = Fault code of the last recorded fault. • The fault code is displayed as a name. See chapter Fault tracing on page 361 for the fault codes and names. The fault name shown for this parameter may be shorter than the corresponding name in the fault listing, which shows the names as they are shown in the fault display.	Fault code text	1	0	
0402	FAULT TIME 1 The day on which the last fault occurred. Either as: • A date – if real time clock is operating. • The number of days after power on – if real time clock is not used, or was not set.	Date dd.mm.yy / power-on days	1	0	
0403	FAULT TIME 2 The time at which the last fault occurred. Either as: • Real time, in format hh:mm:ss – if real time clock is operating. • The time since power on (less the whole days reported in parameter 0402 FAULT TIME 1), in format hh:mm:ss – if real time clock is not used, or was not set. Format on the basic control panel: Time elapsed after power-on in 2-second ticks (minus the whole days stated by signal 0402 FAULT TIME 1). 30 ticks = 60 seconds. For example, value 514 equals 17 minutes and 8 seconds (= 514/30).	Time hh:mm:ss	2 s	0	
0404	SPEED AT FLT The motor speed (rpm) at the time the last fault occurred.	-	1 rpm	0	
0405	FREQ AT FLT The frequency (Hz) at the time the last fault occurred.	-	0.1 Hz	0.0	
0406	VOLTAGE AT FLT The DC bus voltage (V) at the time the last fault occurred.	-	0.1 V	0.0	
0407	CURRENT AT FLT The motor current (A) at the time the last fault occurred.	-	0.1 A	0.0	
0408	TORQUE AT FLT The motor torque (%) at the time the last fault occurred.	-	0.1%	0.0	
0409	Reserved for future use				
0412	PREVIOUS FAULT 1 Fault code of the second last fault. Read-only	Fault code text	1	0	
0413	PREVIOUS FAULT 2 Fault code of the third last fault. Read-only.	Fault code text	1	0	
0414	DI 1-5 AT FLT Status of digital inputs DI1...5 at the time the latest fault occurred (binary). Example: 10000 = DI1 is on, DI2...DI5 are off.				

■ Group 10: Start/Stop/Dir

This group:

- Defines external sources (EXT1, and EXT2) for commands that enable start, stop and direction changes.
- Locks direction or enables direction control. To select between the two external locations use the next group, parameter [1102 EXT1/EXT2 SEL](#).

Group 10: Start/Stop/Dir					
Code	Description	Range	Resolution	Default	S
1001	<p>EXT1 COMMANDS</p> <p>Defines external control location 1 (EXT1) – the configuration of start, stop and direction commands.</p> <p>0 = NOT SEL – No external start, stop and direction command source.</p> <p>1 = DI1 – Two-wire Start/Stop.</p> <ul style="list-style-type: none"> • Start/Stop is through digital input DI1 (DI1 activated = Start; DI1 de-activated = Stop). • Parameter 1003 DIRECTION defines the direction. Selecting 1003 = 3 (request) is the same as 1003 = 1 (fwd). <p>2 = DI1, 2 – Two-wire Start/Stop, Direction.</p> <ul style="list-style-type: none"> • Start/Stop is through digital input DI1 (DI1 activated = Start; DI1 de-activated = Stop). • Direction control (requires parameter 1003 = 3 (request)) is through digital input DI2 (DI2 activated = Reverse; de-activated = Forward). <p>3 = DI1P, 2P – Three-wire Start/Stop.</p> <ul style="list-style-type: none"> • Start/Stop commands are through momentary push-buttons (the P stands for “pulse”). • Start is through a normally open push-button connected to digital input 1. In order to start the drive, the digital input 2 must be activated prior the pulse in 1. • Connect multiple Start push-buttons in parallel. • Stop is through a normally closed push-button connected to digital input 2. • Connect multiple Stop push-buttons in series. • Parameter 1003 DIRECTION defines the direction. Selecting 1003 = 3 (REQUEST) is the same as 1003 = 1 (FWD). <p>4 = DI1P, 2P, 3 – Three-wire Start/Stop, Direction.</p> <ul style="list-style-type: none"> • Start/Stop commands are through momentary push-buttons, as described for DI1P, 2P. • Direction control (requires parameter 1003 = 3 (REQUEST)) is through digital input DI3 (DI3 activated = Reverse; de-activated = Forward). 	0...34	1	1	✓

Group 10: Start/Stop/Dir					
Code	Description	Range	Resolution	Default	S
	<p>5 = DI1P, 2P, 3P – Start Forward, Start Reverse, and Stop.</p> <ul style="list-style-type: none"> Start and Direction commands are given simultaneously with two separate momentary push-buttons (the P stands for “pulse”). Start Forward command is through a normally open push-button connected to digital input DI1. To start the drive, the digital input DI3 must be activated during the pulse in DI1. Start Reverse command is through a normally open push-button connected to digital input DI2. To start the drive, the digital input DI3 must be activated prior the pulse in DI2. Connect multiple Start push-buttons in parallel. Stop is through a normally closed push-button connected to digital input DI3. Connect multiple Stop push-buttons in series. Requires parameter 1003 = 3 (REQUEST). <p>8 = KEYPAD – Control Panel.</p> <ul style="list-style-type: none"> Start/Stop and Direction commands are through the control panel when EXT1 is active. Direction control requires parameter 1003 = 3 (REQUEST). <p>9 = DI1F, 2R – Start/Stop/Direction commands through DI1 and DI2 combinations.</p> <ul style="list-style-type: none"> Start forward = DI1 activated and DI2 de-activated. Start reverse = DI1 de-activated and DI2 activated. Stop = both DI1 and DI2 activated, or both de-activated. Requires parameter 1003 = 3 (REQUEST). <p>10 = COMM – Assigns the fieldbus Command word as the source for the start/stop and direction commands.</p> <ul style="list-style-type: none"> Bits 0,1, 2 of Command word 1 (parameter 0301 FB CMD WORD 1) activates the start/stop and direction commands. See Fieldbus user’s manual for detailed instructions. <p>11 = TIMER 1 – Assigns Start/Stop control to Timer 1 (Timer activated = START; Timer de-activated = STOP). See Group 36: Timed functions.</p> <p>12...14 = TIMER 2... 4 – Assigns Start/Stop control to Timer 2...4. See Timer Function 1 above.</p> <p>20 = DI5 – Start and stop through digital input DI5. 0 = stop, 1 = start. Direction is fixed according to parameter 1003 DIRECTION (setting REQUEST = FORWARD).</p> <p>21 = DI5, 4 – Start and stop through digital input DI5. 0 = stop, 1 = start. Direction through digital input DI4. 0 = forward, 1 = reverse. To control direction, parameter 1003 DIRECTION must be REQUEST.</p> <p>27 = SUPRV1 OVER – Start when the value of supervision parameter 1 goes over the supervision high limit. Stop when the value goes below the low limit. See parameter Group 32: Supervision.</p> <p>28 = SUPRV1 UNDER – Start when the value of the supervision parameter 1 goes below the supervision low limit. Stop when the value goes over the high limit. See parameter Group 32: Supervision.</p> <p>29 = SUPRV2 OVER – See selection SUPRV1 OVER.</p> <p>30 = SUPRV2 UNDER – See selection SUPRV1 UNDER.</p> <p>31 = SUPRV3 OVER – See selection SUPRV1 OVER.</p> <p>32 = SUPRV3 UNDER – See selection SUPRV1 UNDER.</p> <p>33 = SUP1OVER+DI2 – Start and stop as for SUPRV1 OVER. Direction through digital input DI2. 0 = forward, 1 = reverse. To control direction, parameter 1003 DIRECTION setting must be REQUEST.</p> <p>34 = SUP1 UDR+DI2 – Start and stop as for SUPRV1 UNDER. Direction through digital input DI2. 0 = forward, 1 = reverse. To control direction, parameter 1003 DIRECTION setting must be REQUEST.</p>				

Group 10: Start/Stop/Dir					
Code	Description	Range	Resolution	Default	S
1002	EXT2 COMMANDS Defines external control location 2 (EXT2) – the configuration of start, stop and direction commands. • See parameter <i>1001 EXT1 COMMANDS</i> above.	0...34	1	1	✓
1003	DIRECTION Defines the control of motor rotation direction. 1 = FORWARD – Rotation is fixed in the forward direction. 2 = REVERSE – Rotation is fixed in the reverse direction. 3 = REQUEST – Rotation direction can be changed on command.	1...3	1	1	✓

■ Group 11: Reference select

This group defines:

- How the drive selects between command sources.
- Characteristics and sources for REF1 and REF2.

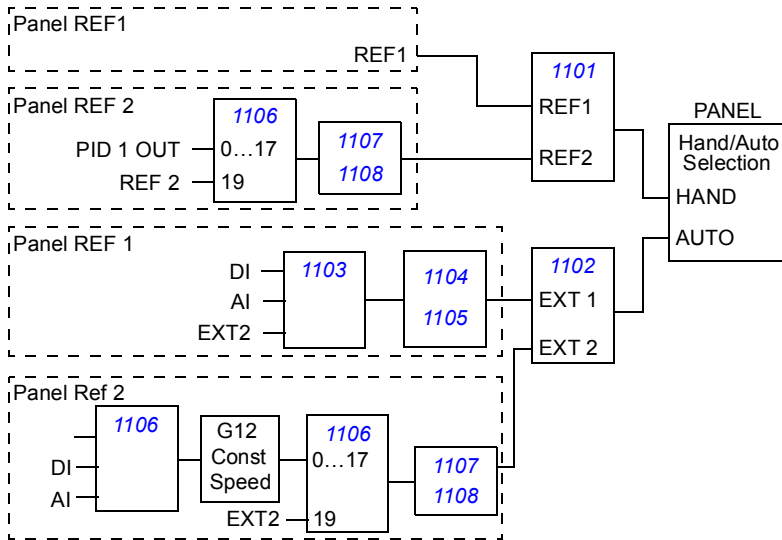

Group 11: Reference select					
Code	Description	Range	Resolution	Default	S
1101	KEYPAD REF SEL Selects the reference controlled in local control mode. 1 = REF1 (Hz/rpm) – Frequency reference in Hz. 2 = REF2 (%) – %-reference.	1,2	1	1	
1102	EXT1/EXT2 SEL Defines the source for selecting between the two external control locations EXT1 or EXT2. Thus, defines the source for Start/Stop/Direction commands and reference signals. 0 = EXT1 – Selects external control location 1 (EXT1). <ul style="list-style-type: none"> • See parameter 1001 EXT1 COMMANDS for EXT1's Start/Stop/Dir definitions. • See parameter 1103 REF1 SELECT for EXT1's reference definitions. 1 = DI1 – Assigns control to EXT1 or EXT2 based on the state of DI1 (DI1 activated = EXT2; DI1 de-activated = EXT1). 2...5 = DI2...DI5 – Assigns control to EXT1 or EXT2 based on the state of the selected digital input. See DI1 above. 7 = EXT2 – Selects external control location 2 (EXT2). <ul style="list-style-type: none"> • See parameter 1002 EXT2 COMMANDS for EXT2's Start/Stop/Dir definitions. • See parameter 1106 REF2 SELECT for EXT2's reference definitions. 8 = COMM – Assigns control of the drive via external control location EXT1 or EXT2 based on the fieldbus control word. <ul style="list-style-type: none"> • Bit 5 of the Command word 1 (parameter 0301 FB CMD WORD 1) defines the active external control location (EXT1 or EXT2). • See Fieldbus user's manual for detailed instructions. 9 = TIMER 1 – Assigns control to EXT1 or EXT2 based on the state of the Timer (Timer activated = EXT2; Timer de-activated = EXT1. See Group 36: Timed functions). 10...12 = TIMER 2... 4 – Assigns control to EXT1 or EXT2 based on the state of the Timer. See TIMER 1 above. -1 = DI1(INV) – Assigns control to EXT1 or EXT2 based on the state of DI1 (DI1 activated = EXT1; DI1 de-activated = EXT2). -2...-5 = DI2(INV)...DI5(INV) – Assigns control to EXT1 or EXT2 based on the state of the selected digital input. See DI1(INV) above.	-5...12	1	0	✓

Group 11: Reference select

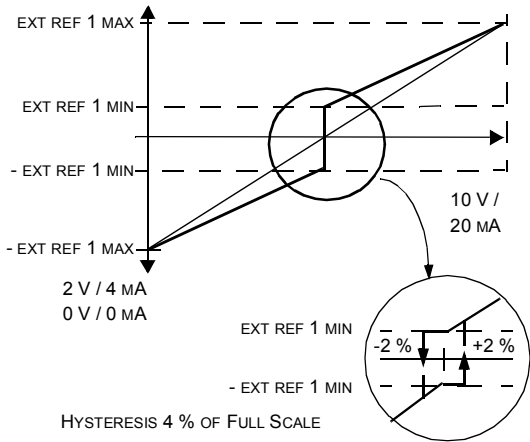
Code	Description	Range	Resolution	Default	S
1103	REF1 SELECT	0...32	1	1	✓
	<p>Selects the signal source for external reference REF1.</p> <p>0 = KEYPAD – Defines the control panel as the reference source. 1 = AI1 – Defines analog input 1 (AI1) as the reference source. 2 = AI2 – Defines analog input 2 (AI2) as the reference source. 3 = AI1/JOYST – Defines analog input 1 (AI1), configured for joystick operation, as the reference source.</p> <ul style="list-style-type: none"> The minimum input signal runs the drive at the maximum reference in the reverse direction. Define the minimum using parameter 1104 REF1 MIN. The maximum input signal runs the drive at maximum reference in the forward direction. Define the maximum using parameter 1105 REF1 MAX. Requires parameter 1103 = 3 (request).  <p>WARNING! Because the low end of the reference range commands full reverse operation, do not use 0 V as the lower end of the reference range. Doing so means that if the control signal is lost (which is a 0 V input) the result is full reverse operation. Instead, use the following set-up so that loss of the analog input triggers a fault, stopping the drive:</p> <ul style="list-style-type: none"> Set parameter 1301 MINIMUM AI1 (1304 MINIMUM AI2) at 20% (2 V or 4 mA). Set parameter 3021 AI1 FAULT LIMIT to a value 5% or higher. Set parameter 3001 AI<MIN FUNCTION to 1 (FAULT). 				

Group 11: Reference select					
Code	Description	Range	Resolution	Default	S
	4 = AI2/JOYST – Defines analog input 2 (AI2), configured for joystick operation, as the reference source. <ul style="list-style-type: none"> • See above (AI1/JOYST) description. 				
	5 = DI3U,4D(R) – Defines digital inputs as the speed reference source (motor potentiometer control). <ul style="list-style-type: none"> • Digital input DI3 increases the speed (the U stands for “up”). • Digital input DI4 decreases the speed (the D stands for “down”). • Stop command resets the reference to zero (the R stands for “reset”). • Parameter 2205 ACCELER TIME 2 controls the reference signal’s rate of change. 				
	6 = DI3U,4D – Same as above (DI3U,4D(R)), except: <ul style="list-style-type: none"> • A Stop command does not reset the reference to zero. The reference is stored. • When the drive restarts, the motor ramps up (at the selected acceleration rate) to the stored reference. 				
	8 = COMM – Defines the fieldbus as the reference source.				
	9 = COMM+AI1 – Defines a fieldbus and analog input 1 (AI1) combination as the reference source. See Analog Input Reference Correction below.				
	10 = COMM*AI1 – Defines a fieldbus and analog input 1 (AI1) combination as the reference source. See Analog Input Reference Correction below.				
	11 = DI3U, 4D(RNC) – Same as DI3U,4D(R) above, except that: <ul style="list-style-type: none"> • Changing the control source (EXT1 TO EXT2, EXT2 TO EXT1, LOC TO REM) does not copy the reference. 				
	12 = DI3U,4D(NC) – Same as DI3U,4D above, except that: <ul style="list-style-type: none"> • Changing the control source (EXT1 TO EXT2, EXT2 TO EXT1, LOC TO REM) does not copy the reference. 				
	14 = AI1+AI2 – Defines an analog input 1 (AI1) and analog input 2 (AI2) combination as the reference source. See Analog Input Reference Correction below.				
	15 = AI1*AI2 – Defines an analog input 1 (AI1) and analog input 2 (AI2) combination as the reference source. See Analog Input Reference Correction below.				
	16 = AI1-AI2 – Defines an analog input 1 (AI1) and analog input 2 (AI2) combination as the reference source. See Analog Input Reference Correction below.				
	17 = AI1/AI2 – Defines an analog input 1 (AI1) and analog input 2 (AI2) combination as the reference source. See Analog Input Reference Correction below.				

Group 11: Reference select

Code	Description	Range	Resolution	Default	S
------	-------------	-------	------------	---------	---

Analog Input Reference Correction

Parameter values 9, 10, and 14...17 use the formula in the following table.

Value setting	Calculation of the AI reference
C + B	C value + (B value - 50% of reference value)
C * B	C value * (B value / 50% of reference value)
C - B	(C value + 50% of reference value) - B value
C / B	(C value * 50% of reference value) / B value

Where:

- C = Main Reference value
(= COMM for values 9, 10 and = 1 for values 14...17).
- B = Correcting reference
(= AI1 for values 9, 10 and = AI2 for values 14...17).

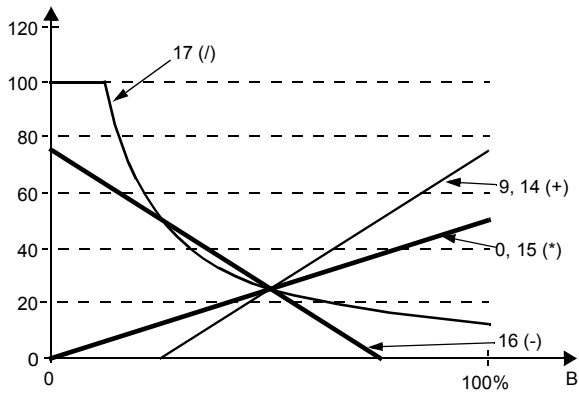

Example:

The figure shows the reference source curves for value settings 9, 10, and 14...17, where:

- C = 25%.
- Parameter **4012 SETPOINT MIN** = 0.
- Parameter **4013 SETPOINT MAX** = 0.
- B varies along the horizontal axis.

REF1 SELECT

20 = KEYPAD(RNC) – Defines the control panel as the reference source. A Stop command resets the reference to zero (R stands for reset.). Changing the control source (EXT1 to EXT2, EXT2 to EXT1) does not copy the reference.

21 = KEYPAD(NC) – Defines the control panel as the reference source. A Stop command does not reset the reference to zero. The reference is stored. Changing the control source (EXT1 to EXT2, EXT2 to EXT1) does not copy the reference.

30 = DI4U,5D – See selection DI3U,4D.

31 = DI4U,5D(NC) – See selection DI3U,4D(NC).

32 = FREQ INPUT – Frequency input.

Group 11: Reference select					
Code	Description	Range	Resolution	Default	S
1104	REF1 MIN Sets the minimum for external reference 1. <ul style="list-style-type: none"> The minimum analog input signal (as a percent of the full signal in volts or amps) corresponds to REF1 MIN in Hz/rpm. Parameter 1301 MINIMUM AI1 or 1304 MINIMUM AI2 sets the minimum analog input signal. These parameters (reference and analog min. and max. settings) provide scale and offset adjustment for the reference. 	0.0 ... 500.0 Hz	0.1 Hz	0.0 Hz	
1105	REF1 MAX Sets the maximum for external reference 1. <ul style="list-style-type: none"> The maximum analog input signal (as a percent of full the signal in volts or amps) corresponds to REF1 MAX in Hz/rpm. Parameter 1302 MAXIMUM AI1 or 1305 MAXIMUM AI2 sets the maximum analog input signal. 	0.0 ... 500.0 Hz	0.1 Hz	60.0 Hz (US) 50.0 Hz (EU)	
1106	REF2 SELECT Selects the signal source for external reference REF2. <p>0...17 – Same as for parameter 1103 REF1 SELECT. 19 = PID1OUT – The reference is taken from the PID1 output. See Group 40: Process PID set 1 and Group 41: Process PID set 2.</p>	0...19	1	19	✓

Group 11: Reference select					
Code	Description	Range	Resolution	Default	S
1107	REF2 MIN	0.0 ... 100.0% (torque: 0 ... 600%)	0.1%	0.0%	
	Sets the minimum for external reference 2. <ul style="list-style-type: none"> • The minimum analog input signal (in volts or amps) corresponds to REF2 MIN in %. • Parameter 1301 MINIMUM A1 or 1304 MINIMUM A2 sets the minimum analog input signal. • This parameter sets the minimum frequency reference. • The value is a percentage of the: <ul style="list-style-type: none"> • maximum frequency or speed • maximum process reference • nominal torque. 				
1108	REF2 MAX	0.0 ... 100.0% (torque: 0 ... 600%)	0.1%	100.0%	
	Sets the maximum for external reference 2. <ul style="list-style-type: none"> • The maximum analog input signal (in volts or amps) corresponds to REF2 MAX in %. • Parameter 1302 MAXIMUM A1 or 1305 MAXIMUM A2 sets the maximum analog input signal. • This parameter sets the maximum frequency reference. • The value is a percentage of the: <ul style="list-style-type: none"> • maximum frequency or speed • maximum process reference • nominal torque 				

■ Group 12: Constant speeds

This group defines a set of constant speeds. In general:

- You can program up to 7 constant speeds, ranging from 0 ... 500 Hz.
- Values must be positive (No negative speed values for constant speeds).
- Constant speed selections are ignored if:
 - the torque control is active, or
 - the process PID reference is followed, or
 - the drive is in local control mode, or
 - PFA (Pump and fan alternation) is active

Note: Parameter [1208 CONST SPEED 7](#) acts also as a so-called fault speed which may be activated if the control signal is lost. For example, see parameters [3001 AI<MIN FUNCTION](#), [3002 PANEL COMM ERR](#) and [3018 COMM FAULT FUNC](#).

Group 12: Constant speeds																																																								
Code	Description	Range	Resolution	Default	S																																																			
1201	CONST SPEED SEL	-13...19	1	3	✓																																																			
	<p>Defines the digital inputs used to select Constant speeds. See general comments in the introduction.</p> <p>0 = NOT SEL – Disables the constant speed function.</p> <p>1 = DI1 – Selects Constant speed 1 with digital input 1.</p> <ul style="list-style-type: none"> Digital input activated = Constant speed 1 activated. <p>2...5 = DI2...DI5 – Selects Constant speed 1 with digital input DI2...DI5.</p> <p>7 = DI1,2 – Selects one of three Constant speeds (1...3) using DI1 and DI2.</p> <ul style="list-style-type: none"> Uses two digital inputs, as defined below (0 = DI de-activated, 1 = DI activated): <table border="1"> <thead> <tr> <th>DI1</th> <th>DI2</th> <th>Function</th> </tr> </thead> <tbody> <tr> <td>0</td> <td>0</td> <td>No constant speed</td> </tr> <tr> <td>1</td> <td>0</td> <td>Constant speed 1 (1202)</td> </tr> <tr> <td>0</td> <td>1</td> <td>Constant speed 2 (1203)</td> </tr> <tr> <td>1</td> <td>1</td> <td>Constant speed 3 (1204)</td> </tr> </tbody> </table> <ul style="list-style-type: none"> Can be set up as a so-called fault speed, which is activated if the control signal is lost. Refer to parameter 3001 AI<MIN FUNCTION and parameter 3002 PANEL COMM ERR. <p>8 = DI2,3 – Selects one of three Constant speeds (1...3) using DI2 and DI3.</p> <ul style="list-style-type: none"> See DI1,2 for code. <p>9 = DI3,4 – Selects one of three Constant speeds (1...3) using DI3 and DI4.</p> <ul style="list-style-type: none"> See DI1,2 for code. <p>10 = DI4,5 – Selects one of three Constant speeds (1...3) using 4 and 5.</p> <ul style="list-style-type: none"> See DI1,2 for code. <p>12 = DI1,2,3 – Selects one of seven Constant speeds (1...7) using DI1, DI2 and DI3.</p> <ul style="list-style-type: none"> Uses three digital inputs, as defined below (0 = DI de-activated, 1 = DI activated): <table border="1"> <thead> <tr> <th>DI1</th> <th>DI2</th> <th>DI3</th> <th>Function</th> </tr> </thead> <tbody> <tr> <td>0</td> <td>0</td> <td>0</td> <td>No constant speed</td> </tr> <tr> <td>1</td> <td>0</td> <td>0</td> <td>Constant speed 1 (1202)</td> </tr> <tr> <td>0</td> <td>1</td> <td>0</td> <td>Constant speed 2 (1203)</td> </tr> <tr> <td>1</td> <td>1</td> <td>0</td> <td>Constant speed 3 (1204)</td> </tr> <tr> <td>0</td> <td>0</td> <td>1</td> <td>Constant speed 4 (1205)</td> </tr> <tr> <td>1</td> <td>0</td> <td>1</td> <td>Constant speed 5 (1206)</td> </tr> <tr> <td>0</td> <td>1</td> <td>1</td> <td>Constant speed 6 (1207)</td> </tr> <tr> <td>1</td> <td>1</td> <td>1</td> <td>Constant speed 7 (1208)</td> </tr> </tbody> </table> <p>13 = DI3,4,5 – Selects one of seven Constant speeds (1...7) using DI3, DI4 and DI5.</p> <ul style="list-style-type: none"> See DI1,2,3 for code. 					DI1	DI2	Function	0	0	No constant speed	1	0	Constant speed 1 (1202)	0	1	Constant speed 2 (1203)	1	1	Constant speed 3 (1204)	DI1	DI2	DI3	Function	0	0	0	No constant speed	1	0	0	Constant speed 1 (1202)	0	1	0	Constant speed 2 (1203)	1	1	0	Constant speed 3 (1204)	0	0	1	Constant speed 4 (1205)	1	0	1	Constant speed 5 (1206)	0	1	1	Constant speed 6 (1207)	1	1	1	Constant speed 7 (1208)
DI1	DI2	Function																																																						
0	0	No constant speed																																																						
1	0	Constant speed 1 (1202)																																																						
0	1	Constant speed 2 (1203)																																																						
1	1	Constant speed 3 (1204)																																																						
DI1	DI2	DI3	Function																																																					
0	0	0	No constant speed																																																					
1	0	0	Constant speed 1 (1202)																																																					
0	1	0	Constant speed 2 (1203)																																																					
1	1	0	Constant speed 3 (1204)																																																					
0	0	1	Constant speed 4 (1205)																																																					
1	0	1	Constant speed 5 (1206)																																																					
0	1	1	Constant speed 6 (1207)																																																					
1	1	1	Constant speed 7 (1208)																																																					

Group 12: Constant speeds

Code	Description	Range	Resolution	Default	S																														
	15...18 = TIMER – Selects constant speed 1, constant speed 2 or the external reference depending on the state of, eg, timer 1 (if the parameter value is 15 = TIMER 1), timer 3 (if the parameter value is 17 = TIMER 3) etc, and the constant speed mode. See parameter 1209 and Group 36: Timed functions .																																		
	<table border="1"> <thead> <tr> <th>1201 =</th> <th>15</th> <th>16</th> <th>17</th> <th>18</th> <th colspan="2">Reference</th> </tr> </thead> <tbody> <tr> <td>Timer:</td> <td>1</td> <td>2</td> <td>3</td> <td>4</td> <td colspan="2">1209 = 1</td> <td>1209 = 2</td> </tr> <tr> <td rowspan="2">Timer State</td> <td colspan="4">0</td> <td colspan="2">External reference</td> <td>Constant speed 1</td> </tr> <tr> <td colspan="4">1</td> <td colspan="2">Constant speed 1</td> <td>Constant speed 2</td> </tr> </tbody> </table>					1201 =	15	16	17	18	Reference		Timer:	1	2	3	4	1209 = 1		1209 = 2	Timer State	0				External reference		Constant speed 1	1				Constant speed 1		Constant speed 2
1201 =	15	16	17	18	Reference																														
Timer:	1	2	3	4	1209 = 1		1209 = 2																												
Timer State	0				External reference		Constant speed 1																												
	1				Constant speed 1		Constant speed 2																												
	19 = TIMER 1 & 2 – Selects a constant speed or the external reference depending on the state of timers 1 and 2 and the constant speed mode. See parameter 1209 and Group 36: Timed functions .																																		
	-1 = DI1(INV) – Selects Constant speed 1 with digital input DI1. <ul style="list-style-type: none"> Inverse operation: Digital input de-activated = Constant speed 1 activated. 																																		
	-2 ... - 5 = DI2(INV)...DI5(INV) – Selects Constant speed 1 with digital input.																																		
	-7 = DI1,2(INV) – Selects one of three Constant speeds (1...3) using DI1 and DI2. <ul style="list-style-type: none"> Inverse operation uses two digital inputs, as defined below (0 = DI de-activated, 1 = DI activated): <table border="1"> <thead> <tr> <th>DI1</th> <th>DI2</th> <th>Function</th> </tr> </thead> <tbody> <tr> <td>1</td> <td>1</td> <td>No constant speed</td> </tr> <tr> <td>0</td> <td>1</td> <td>Constant speed 1 (1202)</td> </tr> <tr> <td>1</td> <td>0</td> <td>Constant speed 2 (1203)</td> </tr> <tr> <td>0</td> <td>0</td> <td>Constant speed 3 (1204)</td> </tr> </tbody> </table>					DI1	DI2	Function	1	1	No constant speed	0	1	Constant speed 1 (1202)	1	0	Constant speed 2 (1203)	0	0	Constant speed 3 (1204)															
DI1	DI2	Function																																	
1	1	No constant speed																																	
0	1	Constant speed 1 (1202)																																	
1	0	Constant speed 2 (1203)																																	
0	0	Constant speed 3 (1204)																																	
	-8 = DI2,3(INV) – Selects one of three Constant speeds (1...3) using DI2 and DI3. <ul style="list-style-type: none"> See above (DI1,2(INV)) for code. 																																		
	-9 = DI3,4(INV) – Selects one of three Constant speeds (1...3) using DI3 and DI4. <ul style="list-style-type: none"> See above (DI1,2(INV)) for code. 																																		
	-10 = DI4,5(INV) – Selects one of three Constant speeds (1...3) using DI4 and DI5. <ul style="list-style-type: none"> See above (DI1,2(INV)) for code. 																																		

Group 12: Constant speeds																																								
Code	Description	Range	Resolution	Default S																																				
	-12 = DI1,2,3(INV) – Selects one of seven constant speeds (1...7) using DI1, DI2 and DI3. <ul style="list-style-type: none"> Inverse operation uses three digital inputs, as defined below (0 = DI de-activated, 1 = DI activated): <table border="1" data-bbox="228 319 1024 609"> <thead> <tr> <th>DI1</th> <th>DI2</th> <th>DI3</th> <th>Function</th> </tr> </thead> <tbody> <tr> <td>1</td> <td>1</td> <td>1</td> <td>No constant speed</td> </tr> <tr> <td>0</td> <td>1</td> <td>1</td> <td>Constant speed 1 (1202)</td> </tr> <tr> <td>1</td> <td>0</td> <td>1</td> <td>Constant speed 2 (1203)</td> </tr> <tr> <td>0</td> <td>0</td> <td>1</td> <td>Constant speed 3 (1204)</td> </tr> <tr> <td>1</td> <td>1</td> <td>0</td> <td>Constant speed 4 (1205)</td> </tr> <tr> <td>0</td> <td>1</td> <td>0</td> <td>Constant speed 5 (1206)</td> </tr> <tr> <td>1</td> <td>0</td> <td>0</td> <td>Constant speed 6 (1207)</td> </tr> <tr> <td>0</td> <td>0</td> <td>0</td> <td>Constant speed 7 (1208)</td> </tr> </tbody> </table>				DI1	DI2	DI3	Function	1	1	1	No constant speed	0	1	1	Constant speed 1 (1202)	1	0	1	Constant speed 2 (1203)	0	0	1	Constant speed 3 (1204)	1	1	0	Constant speed 4 (1205)	0	1	0	Constant speed 5 (1206)	1	0	0	Constant speed 6 (1207)	0	0	0	Constant speed 7 (1208)
DI1	DI2	DI3	Function																																					
1	1	1	No constant speed																																					
0	1	1	Constant speed 1 (1202)																																					
1	0	1	Constant speed 2 (1203)																																					
0	0	1	Constant speed 3 (1204)																																					
1	1	0	Constant speed 4 (1205)																																					
0	1	0	Constant speed 5 (1206)																																					
1	0	0	Constant speed 6 (1207)																																					
0	0	0	Constant speed 7 (1208)																																					
	-13 = DI3,4,5(INV) – Selects one of seven constant speeds (1...3) using DI3, DI4 and DI5. <ul style="list-style-type: none"> See above (DI1,2,3(INV)) for code. 																																							
1202	CONST SPEED 1	0.0 ... 500.0 Hz	0.1 Hz	6.0 (US)																																				
	Defines constant speed 1 (drive output frequency).																																							
1203	CONST SPEED 2	0.0 ... 500.0 Hz	0.1 Hz	12.0																																				
	Defines constant speed 2 (drive output frequency).																																							
1204	CONST SPEED 3	0.0 ... 500.0 Hz	0.1 Hz	18.0																																				
	Defines constant speed 3 (drive output frequency).																																							
1205	CONST SPEED 4	0.0 ... 500.0 Hz	0.1 Hz	24.0																																				
	Defines constant speed 4 (drive output frequency).																																							
1206	CONST SPEED 5	0.0 ... 500.0 Hz	0.1 Hz	30.0																																				
	Defines constant speed 5 (drive output frequency).																																							
1207	CONST SPEED 6	0.0 ... 500.0 Hz	0.1 Hz	48.0																																				
	Defines constant speed 6 (drive output frequency).																																							
1208	CONST SPEED 7	0.0 ... 500.0 Hz	0.1 Hz	60.0																																				
	Defines constant speed 7 (drive output frequency).																																							

Group 12: Constant speeds

Code	Description	Range	Resolution	Default	S															
1209	TIMED MODE SEL Defines timer activated, constant speed mode. Timer can be used to change between external reference and a maximum of three constant speeds, or to change between a maximum of 4 selectable speeds, in other words, constant speeds 1,2,3 and 4. 1 = EXT/CS1/2/3 – Selects an external speed when no timer is active, selects Constant speed 1 when Timer 1 is active, selects Constant speed 2 when Timer 2 is active and selects Constant speed 3 when both Timers 1 and 2 are active.	1...2	1	2	✓															
	<table border="1"> <thead> <tr> <th>TIMER1</th> <th>TIMER2</th> <th>Function</th> </tr> </thead> <tbody> <tr> <td>0</td> <td>0</td> <td>External reference</td> </tr> <tr> <td>1</td> <td>0</td> <td>Constant speed 1 (1202)</td> </tr> <tr> <td>0</td> <td>1</td> <td>Constant speed 2 (1203)</td> </tr> <tr> <td>1</td> <td>1</td> <td>Constant speed 3 (1204)</td> </tr> </tbody> </table>	TIMER1	TIMER2	Function	0	0	External reference	1	0	Constant speed 1 (1202)	0	1	Constant speed 2 (1203)	1	1	Constant speed 3 (1204)				
TIMER1	TIMER2	Function																		
0	0	External reference																		
1	0	Constant speed 1 (1202)																		
0	1	Constant speed 2 (1203)																		
1	1	Constant speed 3 (1204)																		
	2 = CS1/2/3/4 – Selects Constant speed 1 when no timer is active, selects Constant speed 2 when Timer 1 is active, selects Constant speed 3 when Timer 2 is active, selects Constant speed 4 when both timers are active.																			
	<table border="1"> <thead> <tr> <th>TIMER1</th> <th>TIMER2</th> <th>Function</th> </tr> </thead> <tbody> <tr> <td>0</td> <td>0</td> <td>Constant speed 1 (1202)</td> </tr> <tr> <td>1</td> <td>0</td> <td>Constant speed 2 (1203)</td> </tr> <tr> <td>0</td> <td>1</td> <td>Constant speed 3 (1204)</td> </tr> <tr> <td>1</td> <td>1</td> <td>Constant speed 4 (1205)</td> </tr> </tbody> </table>	TIMER1	TIMER2	Function	0	0	Constant speed 1 (1202)	1	0	Constant speed 2 (1203)	0	1	Constant speed 3 (1204)	1	1	Constant speed 4 (1205)				
TIMER1	TIMER2	Function																		
0	0	Constant speed 1 (1202)																		
1	0	Constant speed 2 (1203)																		
0	1	Constant speed 3 (1204)																		
1	1	Constant speed 4 (1205)																		

■ Group 13: Analogue inputs

This group defines the limits and the filtering for analog inputs.

Group 13: Analogue inputs					
Code	Description	Range	Resolution	Default	S
1301	<p>MINIMUM AI1</p> <p>Defines the minimum value of the analog input.</p> <ul style="list-style-type: none"> Define value as a percent of the full analog signal range. See example below. The minimum analog input signal corresponds to parameter 1104 REF1 MIN or 1107 REF2 MIN. MINIMUM AI cannot be greater than MAXIMUM AI. These parameters (reference and analog min. and max. settings) provide scale and offset adjustment for the reference. See figure at parameter 1104 REF1 MIN. <p>Example: To set the minimum analog input value to 4 mA:</p> <ul style="list-style-type: none"> Configure the analog input for 0 ... 20 mA current signal. Calculate the minimum (4 mA) as a percent of full range (20 mA) = 4 mA / 20 mA * 100% = 20% 	-100.0 ... 100.0%	0.1%	20.0%	
1302	<p>MAXIMUM AI1</p> <p>Defines the maximum value of the analog input.</p> <ul style="list-style-type: none"> Define value as a percent of the full analog signal range. The maximum analog input signal corresponds to 1105 REF1 MAX or 1108 REF2 MAX. See figure at parameter 1104 REF1 MIN. 	-100.0 ... 100.0%	0.1%	20.0%	
1303	<p>FILTER AI1</p> <p>Defines the filter time constant for analog input 1 (AI1).</p> <ul style="list-style-type: none"> The filtered signal reaches 63% of a step change within the time specified. 	0.0 ... 10.0 s	0.1 s	0.1 s	
1304	<p>MINIMUM AI2</p> <p>Defines the minimum value of the analog input.</p> <ul style="list-style-type: none"> See parameter 1301 MINIMUM AI1 above. 	100.0 ... 100.0%	0.1%	20.0%	
1305	<p>MAXIMUM AI2</p> <p>Defines the maximum value of the analog input.</p> <ul style="list-style-type: none"> See parameter 1302 MAXIMUM AI1 above. 	-100.0 ... 100.0%	0.1%	100.0%	
1306	<p>FILTER AI2</p> <p>Defines the filter time constant for analog input 2 (AI2).</p> <ul style="list-style-type: none"> See parameter 1303 FILTER AI1 above 	0.0 ... 10.0 s	0.1 s	0.1 s	

■ Group 14: Relay outputs

This group defines the condition that activates each of the relay outputs.

Group 14: Relay outputs					
Code	Description	Range	Resolution	Default	S
1401	RELAY OUTPUT 1	0...69	1	1	
	<p>Defines the event or condition that activates relay 1 – what relay output 1 means.</p> <p>0 = NOT SEL – Relay is not used and is de-energized.</p> <p>1 = READY – Energize relay when drive is ready to function. Requires:</p> <ul style="list-style-type: none"> • Run enable signal present. • No faults exist. • Supply voltage is within range. • Emergency Stop command is not on. <p>2 = RUN – Energize relay when the drive is running.</p> <p>3 = FAULT (-1) – Energize relay when power is applied. De-energizes when a fault occurs.</p> <p>4 = FAULT – Energize relay when a fault is active.</p> <p>5 = ALARM – Energize relay when an alarm is active.</p> <p>6 = REVERSED – Energize relay when motor rotates in reverse direction.</p> <p>7 = STARTED – Energize relay when drive receives a start command (even if Run Enable signal is not present). De-energized relay when drive receives a stop command or a fault occurs.</p> <p>8 = SUPRV1 OVER – Energize relay when first supervised parameter (3201) exceeds the limit (3203).</p> <ul style="list-style-type: none"> • See Group 32: Supervision starting on page 212. <p>9 = SUPRV1 UNDER – Energize relay when first supervised parameter (3201) drops below the limit (3202).</p> <ul style="list-style-type: none"> • See Group 32: Supervision starting on page 212. <p>10 = SUPRV2 OVER – Energize relay when second supervised parameter (3204) exceeds the limit (3206).</p> <ul style="list-style-type: none"> • See Group 32: Supervision starting on page 212. <p>11 = SUPRV2 UNDER – Energize relay when second supervised parameter (3204) drops below the limit (3205).</p> <ul style="list-style-type: none"> • See Group 32: Supervision starting on page 212. <p>12 = SUPRV3 OVER – Energize relay when third supervised parameter (3207) exceeds the limit (3209).</p> <ul style="list-style-type: none"> • See Group 32: Supervision starting on page 212. <p>13 = SUPRV3 UNDER – Energize relay when third supervised parameter (3207) drops below the limit (3208).</p> <ul style="list-style-type: none"> • See Group 32: Supervision starting on page 212. <p>14 = AT SET POINT – Energize relay when the output frequency is equal to the reference frequency.</p> <p>15 = FAULT (RST) – Energize relay when the drive is in a fault condition and will reset after the programmed auto-reset delay.</p> <ul style="list-style-type: none"> • See parameter 3103 DELAY TIME. <p>16 = FLT/ALARM – Energize relay when fault or alarm occurs.</p> <p>17 = EXT CTRL – Energize relay when external control is selected.</p> <p>18 = REF 2 SEL – Energize relay when EXT2 is selected.</p> <p>19 = CONST FREQ– Energize relay when a constant speed is selected.</p>				

Group 14: Relay outputs																																																														
Code	Description	Range	Resolution	Default	S																																																									
	20 = REF LOSS – Energize relay when reference or active control place is lost.																																																													
	21 = OVERCURRENT – Energize relay when an overcurrent alarm or fault occurs.																																																													
	22 = OVERVOLTAGE – Energize relay when an overvoltage alarm or fault occurs.																																																													
	23 = DRIVE TEMP – Energize relay when a drive overtemperature alarm or fault occurs.																																																													
	24 = UNDERVOLTAGE – Energize relay when an undervoltage alarm or fault occurs.																																																													
	25 = AI1 LOSS – Energize relay when AI1 signal is lost.																																																													
	26 = AI2 LOSS – Energize relay when AI2 signal is lost.																																																													
	27 = MOTOR TEMP – Energize relay when a motor overtemperature alarm or fault occurs.																																																													
	28 = STALL – Energize relay when a stall alarm or fault exists.																																																													
	30 = PID SLEEP – Energize relay when the PID sleep function is active.																																																													
	31 = PFA – Use relay to start/stop motor in PFA control (See Group 81: PFA control).																																																													
	<ul style="list-style-type: none"> Use this option only when PFA control is used. Selection activated / deactivated when drive is not running. 																																																													
	32 = AUTOCHANGE – Energize relay when the PFA autochange operation is performed.																																																													
	<ul style="list-style-type: none"> Use this option only when PFA control is used. 																																																													
	33 = FLUX READY – Energize relay when the motor is magnetized and able to supply nominal torque (motor has reached nominal magnetizing).																																																													
	34 = USER MACRO S2 – Energize relay when User Parameter Set 2 is active.																																																													
	35 = COMM – Energize relay based on input from fieldbus communication.																																																													
	<ul style="list-style-type: none"> Fieldbus writes binary code in parameter 0134 COMM RO WORD that can energizes relay 1...relay 4 according to the following: 																																																													
	<table border="1"> <thead> <tr> <th>Parameter 0134</th> <th>Binary</th> <th>RO4 (MREL)</th> <th>RO3 (MREL)</th> <th>RO2 (MREL)</th> <th>DO</th> <th>RO1</th> </tr> </thead> <tbody> <tr> <td>0</td> <td>00000</td> <td>0</td> <td>0</td> <td>0</td> <td>0</td> <td>0</td> </tr> <tr> <td>1</td> <td>00001</td> <td>0</td> <td>0</td> <td>0</td> <td>0</td> <td>1</td> </tr> <tr> <td>2</td> <td>00010</td> <td>0</td> <td>0</td> <td>0</td> <td>1</td> <td>0</td> </tr> <tr> <td>3</td> <td>00011</td> <td>0</td> <td>0</td> <td>0</td> <td>1</td> <td>1</td> </tr> <tr> <td>4</td> <td>00100</td> <td>0</td> <td>0</td> <td>1</td> <td>0</td> <td>0</td> </tr> <tr> <td>5...30</td> <td>...</td> <td>...</td> <td>...</td> <td>...</td> <td>...</td> <td>...</td> </tr> <tr> <td>31</td> <td>11111</td> <td>1</td> <td>1</td> <td>1</td> <td>1</td> <td>1</td> </tr> </tbody> </table>	Parameter 0134	Binary	RO4 (MREL)	RO3 (MREL)	RO2 (MREL)	DO	RO1	0	00000	0	0	0	0	0	1	00001	0	0	0	0	1	2	00010	0	0	0	1	0	3	00011	0	0	0	1	1	4	00100	0	0	1	0	0	5...30	31	11111	1	1	1	1	1					
Parameter 0134	Binary	RO4 (MREL)	RO3 (MREL)	RO2 (MREL)	DO	RO1																																																								
0	00000	0	0	0	0	0																																																								
1	00001	0	0	0	0	1																																																								
2	00010	0	0	0	1	0																																																								
3	00011	0	0	0	1	1																																																								
4	00100	0	0	1	0	0																																																								
5...30																																																								
31	11111	1	1	1	1	1																																																								
	<ul style="list-style-type: none"> 0 = De-energize relay, 1 = Energize relay. 																																																													

Group 14: Relay outputs

Code	Description	Range	Resolution	Default	S																																																								
	<p>36 = COMM(-1) – Energize relay based on input from fieldbus communication.</p> <ul style="list-style-type: none"> Fieldbus writes binary code in parameter 0134 that can energizes relay 1...relay 4 according to the following: <table border="1" style="margin-left: 20px;"> <thead> <tr> <th>Parameter 0134</th> <th>Binary</th> <th>RO4 (MREL)</th> <th>RO3 (MREL)</th> <th>RO2 (MREL)</th> <th>DO</th> <th>RO1</th> </tr> </thead> <tbody> <tr> <td>0</td> <td>00000</td> <td>1</td> <td>1</td> <td>1</td> <td>1</td> <td>1</td> </tr> <tr> <td>1</td> <td>00001</td> <td>1</td> <td>1</td> <td>1</td> <td>1</td> <td>0</td> </tr> <tr> <td>2</td> <td>00010</td> <td>1</td> <td>1</td> <td>1</td> <td>0</td> <td>1</td> </tr> <tr> <td>3</td> <td>00011</td> <td>1</td> <td>1</td> <td>1</td> <td>0</td> <td>0</td> </tr> <tr> <td>4</td> <td>00100</td> <td>1</td> <td>1</td> <td>0</td> <td>1</td> <td>1</td> </tr> <tr> <td>5...30</td> <td>...</td> <td>...</td> <td>...</td> <td>...</td> <td>...</td> <td>...</td> </tr> <tr> <td>31</td> <td>11111</td> <td>0</td> <td>0</td> <td>0</td> <td>0</td> <td>0</td> </tr> </tbody> </table> <ul style="list-style-type: none"> 0 = De-energize relay, 1 = Energize relay. <p>37 = TIMER 1 – Energize relay when timer 1 is activated. See Group 36: Timed functions.</p> <p>38...40 = TIMER 2...4 – Energize relay when Timer 2...4 is active. See TIMER 1 above.</p> <p>41 = MNT TRIG FAN – Energize relay when cooling fan counter is triggered. See Group 29: Maintenance trig.</p> <p>42 = MNT TRIG REV – Energize relay when revolutions counter is triggered. See Group 29: Maintenance trig.</p> <p>43 = MNT TRIG RUN – Energize relay when run time counter is triggered. See Group 29: Maintenance trig.</p> <p>44 = MNT TRIG MWH – Energize relay when power consumption counter is triggered. See Group 29: Maintenance trig.</p> <p>45 = OVERRIDE – Energize relay when override is activated.</p> <p>46 = START DELAY – Energize relay when a start delay is active.</p> <p>47 = USER LOAD C – Energize relay when a user load curve fault or alarm occurs.</p> <p>53 = PIPE FILL – Energize relay when pipe fill is active. See parameter 4421 PIPEFILL ENABLE.</p> <p>54 = PROFILE HIGH – Energize relay when the internal status signal PROFILE HIGH is set to 1. See parameter 4418 APPL PROFILE CTL.</p> <p>55 = INLET PROT – Energize relay when INLET PROT is triggered. See parameter 4401 INLET PROT CTRL.</p> <p>56 = OUTLET PROT – Energize relay when OUTLET PROT is triggered. See parameter 4409 OUTLET PROT CTRL.</p> <p>69 = MOT. HEATING – Energize relay when motor heating is triggered. See parameter 2104 DC HOLD CTL.</p>	Parameter 0134	Binary	RO4 (MREL)	RO3 (MREL)	RO2 (MREL)	DO	RO1	0	00000	1	1	1	1	1	1	00001	1	1	1	1	0	2	00010	1	1	1	0	1	3	00011	1	1	1	0	0	4	00100	1	1	0	1	1	5...30	31	11111	0	0	0	0	0				
Parameter 0134	Binary	RO4 (MREL)	RO3 (MREL)	RO2 (MREL)	DO	RO1																																																							
0	00000	1	1	1	1	1																																																							
1	00001	1	1	1	1	0																																																							
2	00010	1	1	1	0	1																																																							
3	00011	1	1	1	0	0																																																							
4	00100	1	1	0	1	1																																																							
5...30																																																							
31	11111	0	0	0	0	0																																																							
1402	RELAY OUTPUT 2	0...69	1	2																																																									
	<p>Defines the event or condition that activates relay 2 – what relay output 2 means.</p> <ul style="list-style-type: none"> See parameter 1401 RELAY OUTPUT 1 (Relay Output 2 only with MREL-01). 																																																												
1403	RELAY OUTPUT 3	0...69	1	2																																																									
	<p>Defines the event or condition that activates relay 3 – what relay output 3 means.</p> <ul style="list-style-type: none"> See parameter 1401 RELAY OUTPUT 1 (Relay Output 3 only with MREL-01). 																																																												

Group 14: Relay outputs					
Code	Description	Range	Resolution	Default	S
1404	RO 1 ON DELAY Defines the switch-on delay for relay 1. <ul style="list-style-type: none"> On / off delays are ignored when relay output of parameter 1401 RELAY OUTPUT 1 is set to PFA. 	0.0 ... 3600.0 s	0.1 s	0.0 s	
1405	RO 1 OFF DELAY Defines the switch-off delay for relay 1. <ul style="list-style-type: none"> On / off delays are ignored when relay output of parameter 1401 RELAY OUTPUT 1 is set to PFA. 	0.0 ... 3600.0 s	0.1 s	0.0 s	
1406	RO 2 ON DELAY Defines the switch-on delay for relay 2. <ul style="list-style-type: none"> See parameter 1404 RO 1 ON DELAY. 	0.0 ... 3600.0 s	0.1 s	0.0 s	
1407	RO 2 OFF DELAY Defines the switch-on delay for relay 2. <ul style="list-style-type: none"> See parameter 1405 RO 1 OFF DELAY. 	0.0 ... 3600.0 s	0.1 s	0.0 s	
1408	RO 3 ON DELAY Defines the switch-on delay for relay 3. <ul style="list-style-type: none"> See parameter 1404 RO 1 ON DELAY. 	0.0 ... 3600.0 s	0.1 s	0.0 s	
1409	RO 3 OFF DELAY Switch-off delay for relay 3. <ul style="list-style-type: none"> See parameter 1405 RO 1 OFF DELAY. 	0.0 ... 3600.0 s	0.1 s	0.0 s	
1410	RELAY OUTPUT 4 Defines the event or condition that activates relay 4 – what relay output 4 means. <ul style="list-style-type: none"> See parameter 1401 RELAY OUTPUT 1. (Relay Output 2 only with MREL-01) 	0...69	1	0	
1413	RO 4 ON DELAY Defines the switch-on delay for relay 4. <ul style="list-style-type: none"> See parameter 1404 RO 1 ON DELAY. 	0.0 ... 3600.0 s	0.1 s	0.0 s	
1414	RO 4 OFF DELAY Defines the switch-off delay for relay 4. <ul style="list-style-type: none"> See parameter 1405 RO 1 OFF DELAY. 	0.0 ... 3600.0 s	0.1 s	0.0 s	

Group 15: Analogue outputs

This group defines the drive's analog (current signal) outputs. The drive's analog outputs can be:

- Any parameter of *Group 01: Operating data*.
- Limited to programmable minimum and maximum values of output current.
- Scaled (and/or inverted) by defining the minimum and maximum values of the source parameter (or content). Defining an maximum value (parameter *1503 AO1 CONTENT MAX*) that is less than the content minimum value (parameter *1502 AO1 CONTENT MIN*) results in an inverted output.
- Filtered.

Group 15: Analogue outputs					
Code	Description	Range	Resolution	Default	S
1501	AO1 CONTENT SEL Connects a drive signal to analog output AO. • Parameter index in <i>Group 01: Operating data</i> . For example, 102 = <i>0102 SPEED</i> .	0...178	1	103	
1502	AO1 CONTENT MIN Sets the minimum content value. • Content is the parameter selected by parameter <i>1501 AO1 CONTENT SEL</i> . • Minimum value refers to the minimum content value that will be converted to an analog output. • These parameters (content and current min. and max. settings) provide scale and offset adjustment for the output. See the figure.	Depends on selection	-	0.0	

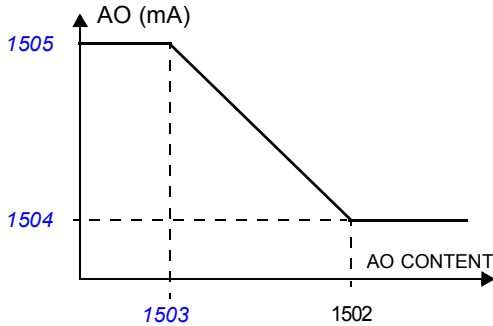
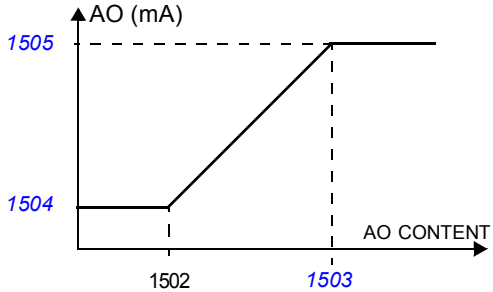

Group 15: Analogue outputs					
Code	Description	Range	Resolution	Default	S
1503	AO1 CONTENT MAX Sets the maximum content value <ul style="list-style-type: none"> Content is the parameter selected by parameter 1501 AO1 CONTENT SEL. Maximum value refers to the maximum content value that will be converted to an analog output. 	Depends on selection	-	60.0	
1504	MINIMUM AO1 Sets the minimum output current.	0.0 ... 20.0 mA	0.1 mA	4.0 mA	
1505	MAXIMUM AO1 Sets the maximum output current.	0.0 ... 20.0 mA	0.1 mA	20.0 mA	
1506	FILTER AO1 Defines the filter time constant for AO1. <ul style="list-style-type: none"> The filtered signal reaches 63% of a step change within the time specified. See the figure in parameter 1303 FILTER AI1. 	0 ... 10 s	0.1 s	0.1 s	

■ Group 16: System controls

This group defines a variety of system level locks, resets and enables.

Group 16: System controls					
Code	Description	Range	Resolution	Default	S
1601	RUN ENABLE Selects the source of the run enable signal. 0 = NOT SEL – Allows the drive to start without an external run enable signal. 1 = DI1 – Defines digital input DI1 as the run enable signal. <ul style="list-style-type: none"> This digital input must be activated for run enable. If the voltage drops and de-activates this digital input, the drive will coast to stop and not start until the run enable signal resumes. 2...5 = DI2...DI5 – Defines digital input DI2...DI5 as the run enable signal. <ul style="list-style-type: none"> See DI1 above. 7 = COMM – Assigns the fieldbus Command word as the source for the run enable signal. <ul style="list-style-type: none"> Bit 6 of the Command word 1 (parameter 0301 FB CMD WORD 1) activates the run disable signal. See fieldbus user's manual for detailed instructions. -1 = DI1(INV) – Defines an inverted digital input 1 as the run enable signal. <ul style="list-style-type: none"> This digital input must be de-activated for run enable. If this digital input activates, the drive will coast to stop and not start until the run enable signal resumes. -2...-5 = DI2(INV)...DI5(INV) – Defines an inverted digital input DI2...DI5 as the run enable signal. <ul style="list-style-type: none"> See DI1(INV) above. 	-5...7	1	0	✓

Group 16: System controls					
Code	Description	Range	Resolution	Default	S
1602	<p>PARAMETER LOCK</p> <p>Determines if the control panel can change parameter values.</p> <ul style="list-style-type: none"> This lock does not limit parameter changes made by macros. This lock does not limit parameter changes written by fieldbus inputs. This parameter value can be changed only if the correct pass code is entered. See parameter 1603 PASS CODE. <p>0 = LOCKED – You cannot use the control panel to change parameter values.</p> <ul style="list-style-type: none"> The lock can be opened by entering the valid pass code to parameter 1603 PASS CODE. <p>1 = OPEN – You can use the control panel to change parameter values.</p> <p>2 = NOT SAVED – You can use the control panel to change parameter values, but they are not stored in permanent memory.</p> <ul style="list-style-type: none"> Set parameter 1607 PARAM. SAVE to 1 (SAVE) to store changed parameter values to memory. 	0...2	1	1	S
1603	<p>PASS CODE</p> <p>Entering the correct pass code allows you to change the parameter lock.</p> <ul style="list-style-type: none"> See parameter 1602 PARAMETER LOCK above. Code 358 allows you to change the value of the parameter 1602 PARAMETER LOCK once. <p>This entry reverts back to 0 automatically.</p>	0...65535	1	0	S
1604	<p>FAULT RESET SEL</p> <p>Selects the source for the fault reset signal. The signal resets the drive after a fault trip if the cause of the fault no longer exists.</p> <p>0 = KEYPAD – Defines the control panel as the only fault reset source.</p> <ul style="list-style-type: none"> Fault reset is always possible with control panel. <p>1 = DI1 – Defines digital input DI1 as a fault reset source.</p> <ul style="list-style-type: none"> Activating the digital input resets the drive. <p>2...5 = DI2...DI5 – Defines digital input DI2...DI5 as a fault reset source.</p> <ul style="list-style-type: none"> See DI1 above. <p>7 = START/STOP – Defines the Stop command as a fault reset source.</p> <ul style="list-style-type: none"> Do not use this option when fieldbus communication provides the start, stop and direction commands. <p>8 = COMM – Defines the fieldbus as a fault reset source.</p> <ul style="list-style-type: none"> The Command word is supplied through fieldbus communication. The bit 4 of the Command word 1 (parameter 0301 FB CMD WORD 1) resets the drive. <p>-1 = DI1(INV) – Defines an inverted digital input 1 as a fault reset source.</p> <ul style="list-style-type: none"> De-activating the digital input resets the drive. <p>-2...-5 = DI2(INV)...DI5(INV) – Defines an inverted digital input DI2...DI5 as a fault reset source.</p> <ul style="list-style-type: none"> See DI1(INV) above. 	-5...7	1	0	S

Group 16: System controls					
Code	Description	Range	Resolution	Default	S
1605	<p>USER PAR SET CHG</p> <p>Defines control for changing the user parameter set.</p> <ul style="list-style-type: none"> • See parameter 9902 APPLIC MACRO. • The drive must be stopped to change User parameter sets. • During a change, the drive will not start. <p>Note: Always save the User parameter set after changing any parameter settings, or performing a motor identification.</p> <ul style="list-style-type: none"> • Whenever the power is cycled, or parameter 9902 APPLIC MACRO is changed, the drive loads the last settings saved. Any unsaved changes to a user parameter set are lost. <p>Note: The value of this parameter (1605) is not included in the User parameter sets, and does not change if User parameter sets change.</p> <p>Note: You can use a relay output to supervise the selection of User parameter set 2.</p> <ul style="list-style-type: none"> • See parameter 1401. <p>0 = NOT SEL – Defines the control panel (using parameter 9902 APPLIC MACRO) as the only control for changing User parameter sets.</p> <p>1 = DI1 – Defines digital input 1 as a control for changing User parameter sets.</p> <ul style="list-style-type: none"> • The drive loads User parameter set 1 on the falling edge of the digital input. • The drive loads User parameter set 2 on the rising edge of the digital input. • The User parameter set changes only when the drive is stopped. <p>2...5 = DI2...DI5 – Defines digital input DI2...DI5 as a control for changing User parameter sets.</p> <ul style="list-style-type: none"> • See DI1 above. <p>-1 = DI1(INV) – Defines an inverted digital input 1 as a control for changing User parameter sets.</p> <ul style="list-style-type: none"> • The drive loads User parameter set 1 on the rising edge of the digital input. • The drive loads User parameter set2 on the falling edge of the digital input. • The User parameter set changes only when the drive is stopped. <p>-2...-5 = DI2(INV)...DI5(INV) – Defines an inverted digital input DI2...DI5 as a control for changing User parameter sets.</p> <ul style="list-style-type: none"> • See DI1(INV) above. 	-5...5	1	0	

Group 16: System controls					
Code	Description	Range	Resolution	Default	S
1606	<p>LOCAL LOCK</p> <p>Defines control for the use of the HAND mode. The HAND mode allows drive control from the control panel.</p> <ul style="list-style-type: none"> When LOCAL LOCK is active, the control panel cannot change to HAND mode. <p>0 = NOT SEL – Disables the lock. The control panel can select HAND and control the drive.</p> <p>Note: The OFF key always stops the drive, regardless of the parameter 1606 LOCAL LOCK value. If LOCAL LOCK is active and the drive is in the AUTO mode when the OFF key is pressed, the drive remains in the AUTO mode but coasts to stop and shows alarm 2017 OFF BUTTON on the control panel display. (This alarm is shown on the control panel only; it is not indicated by relay outputs.) Press the AUTO key to restart the drive.</p> <p>Note: If the drive is in the OFF or HAND mode and LOCAL LOCK is activated (eg, from the control panel or through a digital input), control from the control panel is still possible until the drive is set to the AUTO mode. It is not until then that LOCAL LOCK becomes effective, disabling changing from the AUTO mode to the OFF or HAND mode by pressing the OFF or HAND key.</p> <p>1 = DI1 – Defines digital input 1 as the control for setting the local lock.</p> <ul style="list-style-type: none"> Activating the digital input locks out local control. De-activating the digital input enable the HAND selection. <p>2...5 = DI2...DI5 – Defines digital input DI2...DI5 as the control for setting the local lock.</p> <ul style="list-style-type: none"> See DI1 above. <p>7 = ON – Sets the lock. The control panel cannot select HAND, and cannot control the drive.</p> <p>8 = COMM – Defines bit 14 of the Command word 1 as the control for setting the local lock.</p> <ul style="list-style-type: none"> Command word is supplied through fieldbus communication. Command word is parameter <i>0301 FB CMD WORD 1</i>. <p>-1 = DI1(INV) – Defines an inverted digital input DI1 as the control for setting the local lock.</p> <ul style="list-style-type: none"> De-activating the digital input locks out local control. Activating the digital input enable the HAND selection. <p>-2...-5 = DI2(INV)...DI5(INV) – Defines an inverted digital input DI2...DI5 as the control for setting the local lock.</p> <ul style="list-style-type: none"> See DI1(INV) above. 	-5...8	1	0	
1607	<p>PARAM. SAVE</p> <p>Saves all altered parameters to permanent memory.</p> <ul style="list-style-type: none"> Parameters altered through a fieldbus are not automatically saved to permanent memory. To save, you must use this parameter. If parameter <i>1602 PARAMETER LOCK</i> = 2 (NOT SAVED), parameters altered from the control panel are not saved. To save, you must use this parameter. If parameter <i>1602 PARAMETER LOCK</i> = 1 (OPEN), parameters altered from the control panel are stored immediately to permanent memory. <p>0 = DONE – Value changes automatically when all parameters are saved.</p> <p>1 = SAVE... – Saves altered parameters to permanent memory.</p>	0, 1	1	0	

Group 16: System controls					
Code	Description	Range	Resolution	Default	S
1608	<p>START ENABLE 1</p> <p>Selects the source of the start enable 1 signal.</p> <p>Note: Start enable functionality differs from the run enable functionality.</p> <p>0 = NOT SEL – Allows the drive to start without an external start enable signal.</p> <p>1 = DI1 – Defines digital input DI1 as the start enable 1 signal.</p> <ul style="list-style-type: none"> This digital input must be activated for start enable 1 signal. If the voltage drops and de-activates this digital input, the drive will coast to stop and show alarm 2021 START ENABLE 1 MISSING on panel display. The drive will not start until start enable 1 signal resumes. <p>2...5 = DI2...DI5 – Defines digital input DI2...DI5 as the start enable 1 signal.</p> <ul style="list-style-type: none"> See DI1 above. <p>7 = COMM – Assigns the fieldbus Command word as the source for the start enable 1 signal.</p> <ul style="list-style-type: none"> Bit 2 of the Command word 2 (parameter 0302 FB CMD WORD 2) activates the start disable 1 signal. See fieldbus user's manual for detailed instructions. <p>-1 = DI1(INV) – Defines an inverted digital input DI1 as the start enable 1 signal.</p> <p>-2...-5 = DI2(INV)...DI5(INV) – Defines an inverted digital input DI2...DI5 as the start enable 1 signal.</p> <ul style="list-style-type: none"> See DI1(INV) above. 	-5...7	1	4	
<p>The diagram illustrates the timing sequence for starting the drive and opening the damper. It shows the following signals and their states over time:</p> <ul style="list-style-type: none"> Drive started: A step function that transitions from low to high. START/STOP COMMAND: A step function that transitions from low to high, occurring after the drive starts. START ENABLE SIGNAL: A step function that transitions from low to high, occurring after the start command. Relay energized: A step function that transitions from low to high, occurring after the start enable signal. Relay de-energized: A step function that transitions from high to low, occurring after the relay is energized. STARTED RELAY STATUS: A step function that transitions from low to high, occurring after the relay is energized. Damper closed: A step function that transitions from low to high, occurring after the relay is energized. Damper opening time: The time interval between the damper closing signal and the damper opening signal. Damper open: A step function that transitions from low to high, occurring after the damper opening time. Damper closing time: The time interval between the damper opening signal and the damper closing signal. DAMPER STATUS: A step function that transitions from low to high, occurring after the damper opening time. RUN ENABLE SIGNAL: A step function that transitions from low to high, occurring after the damper opening time. MOTOR STATUS: A step function that transitions from low to high, occurring after the run enable signal. Acceleration time: The time interval between the run enable signal and the motor status signal. Deceleration time: The time interval between the motor status signal and the end of the run enable signal. 					

Group 16: System controls					
Code	Description	Range	Resolution	Default	S
1609	<p>START ENABLE 2</p> <p>Selects the source of the start enable 2 signal.</p> <p>Note: Start enable functionality differs from the run enable functionality.</p> <p>0 = NOT SEL – Allows the drive to start without an external start enable signal.</p> <p>1 = DI1 – Defines digital input DI1 as the start enable 2 signal. This digital input must be activated for start enable 2 signal. If the voltage drops and de-activates this digital input, the drive will coast to stop and show alarm 2022 START ENABLE 2 MISSING on the panel display. The drive will not start until start enable 2 signal resumes.</p> <p>2...5 = DI2...DI5 – Defines digital input DI2...DI5 as the start enable 2 signal. See DI1 above.</p> <p>7 = COMM – Assigns the fieldbus Command word as the source for the start enable 2 signal. Bit 3 of the Command word 2 (parameter 0302) activates the start disable 2 signal. See fieldbus user's manual for detailed instructions.</p> <p>-1 = DI1(INV) – Defines an inverted digital input DI1 as the start enable 2 signal.</p> <p>-2...-5 = DI2(INV)...DI5(INV) – Defines an inverted digital input DI2...DI5 as the start enable 2 signal.</p> <ul style="list-style-type: none"> • See DI1(INV) above. 	-5...7	1	0	
1610	<p>DISPLAY ALARMS</p> <p>Controls the visibility of the following alarms:</p> <ul style="list-style-type: none"> • 2001 OVERCURRENT • 2002 OVERVOLTAGE • 2003 UNDERVOLTAGE • 2009 DEVICE OVERTEMP. <p>For more information, see chapter Fault tracing.</p> <p>0 = NO – The above alarms are suppressed.</p> <p>1 = YES – All of the above alarms are enabled.</p>	0, 1	1	1	
1611	<p>PARAMETER VIEW</p> <p>Selects the parameter view, in other words, which parameters are shown.</p> <p>Note: This parameter is visible only when it is activated by the optional FlashDrop device. The FlashDrop is designed for fast copying of parameters to unpowered drives. It allows fast customization of the parameter list, for example, selected parameters can be hidden. For more information, see <i>MFDT-01 FlashDrop User's Manual</i> [3AFE68591074 (English)].</p> <p>FlashDrop parameter values are activated by setting parameter 9902 APPLIC MACRO to 31 (LOAD FD SET).</p> <p>1 = FLASHDROP – FlashDrop parameter list is shown. Does not include short parameter list. Parameters that are hidden by the FlashDrop device are not visible.</p> <p>2 = SHORT VIEW – Shows only a subset of all signals and parameters</p> <p>3 = LONG VIEW – Shows all signals and parameters.</p>	1...3	1	2	
1612	<p>FAN CONTROL</p> <p>Selects the heat sink fan On/Off control for forcing the cooling fan of the drive constantly On,</p> <p>0 = AUTO – Automatic fan control.</p> <p>1 = ON – Fan is always On.</p>	0, 1	1	0	

■ Group 17: Override

This group defines the source for the override activation signal, the override speed/frequency and pass code and how the override is enabled and disabled.

When override DI is activated, the drive stops and then accelerates to the preset speed or frequency. When the DI is deactivated the drive stops and reboots. If the start command, run enable and start enables are active in the AUTO mode the drive starts automatically and continues normally after override mode. In the HAND mode the drive returns to OFF mode.

When override is active:

- Drive runs at preset speed.
- Drive ignores all keypad commands.
- Drive ignores all commands from communication links.
- Drive ignores all digital inputs except override activation/deactivation, RUN ENABLE and START ENABLE.
- Drive displays alarm message **2020 OVERRIDE**.

The following faults are ignored:

3	DEV OVERTEMP
5	OVERLOAD
6	DC UNDERVOLT
7	AI1 LOSS
8	AI2 LOSS
9	MOT OVERTEMP
10	PANEL LOSS
12	MOTOR STALL
14	EXT FAULT 1
15	EXT FAULT 2
17	UNDERLOAD
18	THERM FAIL
21	CURR MEAS
22	SUPPLY PHASE
24	OVERSPEED
28	SERIAL 1 ERR
29	EFB CON FILE
30	FORCE TRIP
31	EFB 1

32	EFB 2
33	EFB 3
34	MOTOR PHASE
1001	PAR PFA REF NEG
1002	PAR PFC IOCONF
1003	PAR AI SCALE
1004	PAR AO SCALE
1006	PAR EXT RO
1007	PAR FIELDBUS MISSING
1008	PAR PFA MODE

Commissioning the override mode

1. Enter the parameters in all groups as needed, except *Group 17: Override*.
2. Select the digital input that will activate the override mode (parameter *1701 OVERRIDE SEL*).
3. Enter the frequency reference for the override mode with parameter *1702 OVERRIDE FREQ*.
4. Enter the pass code (358) at parameter *1704 OVERR PASS CODE*.
5. Enable the override mode with parameter *1705 OVERRIDE*.

Changing the override parameters

1. If override mode is already enabled, disable it:
 - Enter the pass code (358) at parameter *1704 OVERR PASS CODE*.
 - Disable the override mode with parameter *1705 OVERRIDE*.
 2. If needed, load the override parameter set with parameter *9902 APPLIC MACRO*.
 3. Change the parameters as needed, except *Group 17: Override*.
 4. Select the digital input that will activate the override mode (parameter *1701 OVERRIDE SEL*).
 5. Enter the frequency reference for the override mode with parameter *1702 OVERRIDE FREQ*.
 6. Enter the pass code (358) at parameter *1704 OVERR PASS CODE*.
 7. Enable the override mode with parameter *1705 OVERRIDE*. The drive replaces the override parameter set with new values of all parameters.
-

Group 17: Override					
Code	Description	Range	Resolution	Default	S
1701	<p>OVERRIDE SEL</p> <p>Selects the source of the override activation signal.</p> <p>0 = NOT SEL – Override activation signal not selected.</p> <p>1 = DI1 – Defines digital input DI1 as the override activation signal.</p> <ul style="list-style-type: none"> This digital input must be activated for override activation signal. <p>2...5 = DI2...DI5 – Defines digital input DI2...DI5 as the override activation signal.</p> <ul style="list-style-type: none"> See DI1 above. <p>-1 = DI1(INV) – Defines an inverted digital input DI1 as the override activation signal.</p> <p>-2...-5 = DI2(INV)...DI5(INV) – Defines an inverted digital input DI2...DI5 as the override activation signal.</p> <ul style="list-style-type: none"> See DI1(INV) above. 	-5...5	1	0	
1702	<p>OVERRIDE FREQ</p> <p>Defines a preset frequency for the override.</p>	-500 ... 500 Hz	0.1	0.0	
1704	<p>OVERR PASS CODE</p> <p>Entering the correct override pass code unlocks parameter 1705 OVERRIDE for one change.</p> <ul style="list-style-type: none"> Enter the pass code always before changing the value of the parameter 1705. The pass code is 358. The entry reverts back to zero automatically. 	0...65535	1	0	
1705	<p>OVERRIDE</p> <p>Selects whether the override is enabled or disabled.</p> <p>0 = OFF – Override disabled.</p> <p>1 = ON – Override enabled.</p> <ul style="list-style-type: none"> When enabled, the drive stores the values of all parameters into an override parameter set (see parameter 9902 APPLIC MACRO) and the parameters in Group 17: Override will be write protected (except parameter 1704 OVERR PASS CODE). To change the other parameters in Group 17: Override, override has to be disabled. <p>2 = LOAD – Loads the saved override set into use (as an active parameter set).</p>	0...2	1	0	
1706	<p>OVERRIDE DIR</p> <p>Selects the source of the override direction signal.</p> <p>0 = FORWARD – Assigns forward as the override direction.</p> <p>1 = DI1 – Defines digital input 1 as the override direction signal.</p> <ul style="list-style-type: none"> Activating the digital input selects the forward direction. De-activating the digital input selects the reverse direction. <p>2...5 = DI2...DI5 – Defines digital input DI2...DI5 as the override direction signal.</p> <p>See DI1 above.</p> <p>7 = REVERSE – Assigns reverse as the override direction.</p> <p>-1 = DI1(INV) – Defines an inverted digital input DI1 as the override direction signal.</p> <ul style="list-style-type: none"> De-activating the digital input selects the forward direction. Activating the digital input selects the reverse direction. <p>-2...-5 = DI2(INV)...DI5(INV) – Defines an inverted digital input DI2...DI5 as the override direction signal.</p> <ul style="list-style-type: none"> See DI1(INV) above. 				

Group 17: Override					
Code	Description	Range	Resolution	Default	S
1707	<p>OVERRIDE REF</p> <p>Selects the source of the override reference.</p> <p>1 = CONSTANT – Selects a preset frequency or speed for the override. The frequency value is defined by parameter 1702 OVERRIDE FREQ.</p> <p>2 = PID – The reference is taken from the PID output, see group Group 40: Process PID set 1.</p> <p>Note: The following conditions must be met when using PID in the override mode:</p> <ul style="list-style-type: none"> • PID1 setpoint (parameter 4010 SET POINT SEL) can be either A1, A2 OR INTERNAL PID1 parameter set 1 must be active (parameter 4027 PID 1 PARAM SET = set 1). • Override direction (parameter 1706 OVERRIDE DIR) can be either 0 = forward or 7 = reverse. 				

■ Group 18: Freq in & tran out

This group defines the frequency input and transistor output signal processing.

Group 18: Freq in & tran out					
Code	Description	Range	Resolution	Default	S
1801	<p>FREQ INPUT MIN</p> <p>Defines the minimum input value when DI5 is used as a frequency input. See section Frequency input on page 113.</p>	0 ... 16000 Hz	1 = 1 Hz	0 Hz	
1802	<p>FREQ INPUT MAX</p> <p>Defines the maximum input value when DI5 is used as a frequency input. See section Frequency input on page 113.</p>	0 ... 16000 Hz	1 = 1 Hz	1000 Hz	
1803	<p>FILTER FREQ IN</p> <p>Defines the filter time constant for frequency input, ie the time within 63% of a step change is reached. See section Frequency input on page 113.</p>	0.0 ... 10.0 s	1 = 0.1 s	0.1 s	
1804	<p>TO MODE</p> <p>Selects the operation mode for the transistor output TO. See section Transistor output on page 113.</p> <p>0 = DIGITAL – Transistor output is used as a digital output DO.</p> <p>1 = FREQUENCY – Transistor output is used as a frequency output FO.</p>			DIGITAL	
1805	<p>DO SIGNAL</p> <p>Selects a drive status indicated through digital output DO. See parameter 1401 RELAY OUTPUT 1.</p>			RUN	
1806	<p>DO ON DELAY</p> <p>Defines the operation delay for digital output DO.</p>	0.0 ... 3600.0 s	1 = 0.1 s	0.0 s	
1807	<p>DO OFF DELAY</p> <p>Defines the release delay for digital output DO.</p>	0.0 ... 3600.0 s	1 = 0.1 s	0.0 s	
1808	<p>FO CONTENT SEL</p> <p>Selects a drive signal to be connected to frequency output FO. Parameter index in Group 01: Operating data, for example, 102 = 0102 SPEED.</p>	0...178		104	

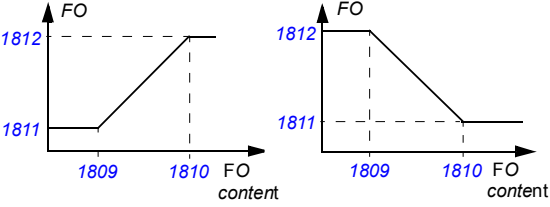
Group 18: Freq in & tran out					
Code	Description	Range	Resolution	Default	S
1809	<p>FO CONTENT MIN</p> <p>Defines the minimum frequency output FO signal value. Signal is selected with parameter 1808 FO CONTENT SEL.</p> <p>FO minimum and maximum correspond to 1811 MINIMUM FO and 1812 MAXIMUM FO settings as follows:</p>  <p>Setting range depends on parameter 1808 FO CONTENT SEL setting.</p>	-	-	-	
1810	<p>FO CONTENT MAX</p> <p>Defines the maximum frequency output FO signal value. Signal is selected with parameter 1808 FO CONTENT SEL. See parameter 1809 FO CONTENT MIN. Setting range depends on parameter 1808 FO CONTENT SEL setting.</p>	-	-	-	
1811	<p>MINIMUM FO</p> <p>Defines the minimum value for frequency output FO. See parameter 1809 FO CONTENT MIN.</p>	10 ... 16000 Hz	1 = 1 Hz	10 Hz	
1812	<p>MAXIMUM FO</p> <p>Defines the maximum value for frequency output FO. See parameter 1809 FO CONTENT MIN.</p>	10 ... 16000 Hz	1 = 1 Hz	1000 Hz	
1813	<p>FILTER FO</p> <p>Defines the filter time constant for frequency output FO, ie, the time within 63% of a step change is reached.</p>	0.0 ... 10.0 s	1 = 0.1 s	0.1 s	
1814	<p>DI 1 ON DELAY</p> <p>Defines the delay from the signal change to the change of the digital input DI to the ON state.</p>	0.0 ... 3600.0 s	1 = 0.1 s	0.0 s	
1815	<p>DI 1 OFF DELAY</p> <p>Defines the delay from the signal change to the change of the digital input DI to the OFF state.</p>	0.0 ... 3600.0 s	1 = 0.1 s	0.0 s	
1816	<p>DI 2 ON DELAY</p> <p>See parameter 1814 DI 1 ON DELAY.</p>			0.0 s	
1817	<p>DI 2 OFF DELAY</p> <p>See parameter 1815 DI 1 OFF DELAY.</p>			0.0 s	
1818	<p>DI 3 ON DELAY</p> <p>See parameter 1814 DI 1 ON DELAY.</p>			0.0 s	
1819	<p>DI 3 OFF DELAY</p> <p>See parameter 1815 DI 1 OFF DELAY.</p>			0.0 s	

Group 18: Freq in & tran out					
Code	Description	Range	Resolution	Default	S
1820	DI 4 ON DELAY See parameter 1814 DI 1 ON DELAY .			0.0 s	
1821	DI 4 OFF DELAY See parameter 1815 DI 1 OFF DELAY .			0.0 s	
1822	DI 5 ON DELAY See parameter 1814 DI 1 ON DELAY .			0.0 s	
1823	DI 5 OFF DELAY See parameter 1815 DI 1 OFF DELAY .			0.0 s	

■ Group 20: Limits

This group defines minimum and maximum limits to follow in driving the motor – speed, frequency, current, torque, etc.

Group 20: Limits					
Code	Description	Range	Resolution	Default	S
2003	MAX CURRENT Defines the maximum output current (A) supplied by the drive to the motor.	0.0 ... 1.1 * I _{2N}	0.1 A	1.1 * I _{2N}	✓
2006	UNDERVOLT CTRL Sets the DC undervoltage controller on or off. When on: <ul style="list-style-type: none"> • If the DC bus voltage drops due to loss of input power, the undervoltage controller decreases the motor speed in order to keep the DC bus voltage above the lower limit. • When the motor speed decreases, the inertia of the load causes regeneration back into the drive, keeping the DC bus charged, and preventing an undervoltage trip. • The DC undervoltage controller increases power loss ride-through on systems with a high inertia, such as a centrifuge or a fan. 0 = DISABLE – Disables controller. 1 = ENABLE (TIME) – Enables controller with 500 ms time limit for operation. 2 = ENABLE – Enables controlled without maximum time limit for operation.	0...2	1	2	
2007	MINIMUM FREQ Defines the minimum limit for the drive output frequency. <ul style="list-style-type: none"> • A positive or zero minimum speed frequency defines two ranges, one positive and one negative. • A negative minimum speed frequency defines one speed range. See figure. Note: Keep MINIMUM FREQ ≤ MAXIMUM FREQ.	-500.0 ... 500.0 Hz	0.1 Hz	0.0 Hz	✓
	<p>The figure consists of two separate frequency range diagrams. The top diagram shows a horizontal axis for Frequency (Freq) and Time. A vertical line at 0 represents the zero minimum frequency (2008). A vertical line at a positive value (2007) represents the positive minimum frequency. The region between 0 and 2007 is shaded and labeled 'Frequency range allowed'. A note indicates '2007 value is < 0'. The bottom diagram shows a horizontal axis for Frequency (Freq) and Time. A vertical line at 0 represents the zero minimum frequency (-2008). A vertical line at a negative value (-2007) represents the negative minimum frequency. The region between -2007 and 0 is shaded and labeled 'Frequency range allowed'. A note indicates '2007 value is ≥ 0'.</p>				
2008	MAXIMUM FREQ Defines the maximum limit for the drive output frequency.	0.0 ... 500.0 Hz	0.1 Hz	60.0 Hz (US)	✓

■ Group 21: Start/Stop

This group defines how the motor starts and stops. The drive supports several start and stop modes.

Group 21: Start/Stop					
Code	Description	Range	Resolution	Default	S
2101	<p>START FUNCTION</p> <p>Selects the motor start method.</p> <p>1 = AUTO – The drive starts the motor instantly from zero frequency. If flying start is required, use selection SCAN START.</p> <p>2 = DC MAGN – The drive pre-magnetizes the motor with DC current before the start. The pre-magnetizing time is defined by parameter 2103 DC MAGN TIME.</p> <p>Note: Starting to a rotating machine is not possible when DC MAGN is selected.</p> <p>⚠ WARNING! The drive will start after the set pre-magnetizing time has passed even if the motor magnetization is not completed. Ensure always in applications where a full break-away torque is essential, that the constant magnetizing time is long enough to allow generation of full magnetization and torque.</p> <p>4 = TORQ BOOST – Torque boost should be selected if a high break-away torque is required. The drive pre-magnetizes the motor with DC current before the start. The pre-magnetizing time is defined by parameter 2103 DC MAGN TIME. Torque boost is applied at start. Torque boost is stopped when output frequency exceeds 20 Hz or when it is equal to the reference value. See parameter 2110 TORQ BOOST CURR.</p> <p>Note: Starting to a rotating machine is not possible when TORQ BOOST is selected.</p> <p>⚠ WARNING! The drive will start after the set pre-magnetizing time has passed although the motor magnetization is not completed. Ensure always in applications where a full break-away torque is essential, that the constant magnetizing time is long enough to allow generation of full magnetization and torque.</p> <p>6 = SCAN START – Frequency scanning flying start (starting the drive connected to a rotating machine). Based on frequency scanning (interval 2008 MAXIMUM FREQ...2007 MINIMUM FREQ) to identify the frequency. If frequency identification fails, DC magnetization is used (see selection DC MAGN).</p> <p>7 = SCAN + BOOST – Combines scanning start (starting the drive connected to a rotating machine) and torque boost. See selections SCANSTART and TORQ BOOST. If frequency identification fails, torque boost is used.</p>	1...7	1	6	
2102	<p>STOP FUNCTION</p> <p>Selects the motor stop method.</p> <p>1 = COAST – Selects cutting off the motor power as the stop method. The motor coasts to stop.</p> <p>2 = RAMP – Selects using a deceleration ramp</p> <ul style="list-style-type: none"> Deceleration ramp is defined by 2203 DECELER TIME 1 or 2206 DECELER TIME 2 (whichever is active). 	1, 2	1	1	

Group 21: Start/Stop					
Code	Description	Range	Resolution	Default	S
2103	DC MAGN TIME Defines the pre-magnetizing time for the DC Magnetizing start mode. <ul style="list-style-type: none"> Use parameter 2101 START FUNCTION to select the start mode. After the start command, the drive pre-magnetizes the motor for the time defined here, and then starts the motor. Set the pre-magnetizing time just long enough to allow full motor magnetization. Too long a time heats the motor excessively. 	0.00 ... 10.00 s	0.01 s	0.30 s	
2104	DC HOLD CTL Enables or disables the Motor heating function. The function keeps the motor warm at low temperatures. 0 = NOT SEL – Disables the Motor heating function. 1 = MOT. HEATING – Enables the Motor heating function. The function is activated by parameter 2115 MOT. HEATING SEL .	0...3	1	0	
2106	DC CURR REF Defines the DC current control reference as a percentage of parameter 9906 MOTOR NOM CURR .	0 ... 100%	1%	30%	
2107	DC BRAKE TIME Defines the DC brake time. Note: DC brake is activated when value is greater than 0.	0 ... 250 s	0.1 s	0 s	
2108	START INHIBIT Sets the Start inhibit function on or off. If the drive is not actively started and running, the Start inhibit function ignores a pending start command in any of the following situations and a new start command is required: <ul style="list-style-type: none"> Fault is reset. Run enable (parameter 1601 RUN ENABLE) activates while start command is active. Mode changes from local to remote. Control switches from EXT1 to EXT2/Control switches from EXT2 to EXT1. 0 = OFF – Disables the Start inhibit function. 1 = ON – Enables the Start inhibit function.	0, 1	1	0	✓

Group 21: Start/Stop					
Code	Description	Range	Resolution	Default	S
2109	<p>EMERG STOP SEL</p> <p>Defines control of the Emergency stop command. When activated:</p> <ul style="list-style-type: none"> • Emergency stop decelerates the motor using the emergency stop ramp (parameter 2208 EMERG DEC TIME). • Requires an external stop command and removal of the emergency stop command before drive can restart. <p>0 = NOT SEL – Disables the Emergency stop function through digital inputs. 1 = DI1 – Defines digital input 1 as the control for Emergency stop command. <ul style="list-style-type: none"> • Activating the digital input issues an Emergency stop command. • De-activating the digital input removes the Emergency stop command. 2...5 = DI2...DI5 – Defines digital input DI2...DI5 as the control for Emergency stop command. <ul style="list-style-type: none"> • See DI1 above. -1 = DI1(INV) – Defines an inverted digital input DI1 as the control for Emergency stop command. <ul style="list-style-type: none"> • De-activating the digital input issues an Emergency stop command. • Activating the digital input removes the Emergency stop command. -2...-5 = DI2(INV)...DI5(INV) – Defines an inverted digital input DI2...DI5 as the control for Emergency stop command. <ul style="list-style-type: none"> • See DI1(INV) above. </p>	-5...5	1	0	
2110	<p>TORQ BOOST CURR</p> <p>Sets the maximum supplied current during torque boost.</p> <ul style="list-style-type: none"> • See parameter 2101 START FUNCTION. 	15 ... 300%	1	100%	
2113	<p>START DELAY</p> <p>Defines the Start delay. After the conditions for start have been fulfilled, the drive waits until the delay has elapsed and then starts the motor. Start delay can be used with all start modes.</p> <ul style="list-style-type: none"> • If START DELAY = zero, the delay is disabled. • During the Start delay, alarm 2028 START DELAY is shown. 				
2114	<p>HEATING CURR REF [%]</p> <p>Defines the amount of current to use for motor heating relative to the nominal current of the motor.</p>	0.0...30.0%	0.1%	0.0%	

Group 21: Start/Stop					
Code	Description	Range	Resolution	Default	S
2115	<p>MOT. HEATING SEL</p> <p>Selects the source for controlling motor heating.</p> <p>-5...-1 = DI1 (INV)...DI5 (INV) – Inverted digital input DI. (0 = Motor heating is On, 1 = Motor heating is Off).</p> <p>0 (default) = OFF – Motor heating is inactive. Can also be used to switch off the injection during heating.</p> <p>1...5 = DI1...DI5 – Digital input DI1...DI5. (1 = Motor heating is On, 0 = Motor heating is Off).</p> <p>7 = COMM – Serial communication as the control for motor heating.</p> <p>8 = ON – Motor heating active (during stop).</p> <p>When motor heating is active, drive shows the alarm 2038 MOTOR HEATING ACTIVE.</p>	-5...8	1	0	

■ Group 22: Accel/Decel

This group defines ramps that control the rate of acceleration and deceleration. You define these ramps as a pair, one for acceleration and one for deceleration. You can define two pairs of ramps and use a digital input to select one or the other pair.

Group 22: Accel/Decel					
Code	Description	Range	Resolution	Default	S
2201	<p>ACC/DEC 1/2 SEL</p> <p>Defines control for selection of acceleration/deceleration ramps.</p> <ul style="list-style-type: none"> Ramps are defined in pairs, one each for acceleration and deceleration. See below for the ramp definition parameters. <p>0 = NOT SEL – Disables selection, the first ramp pair is used.</p> <p>1 = DI1 – Defines digital input 1 as the control for ramp pair selection.</p> <ul style="list-style-type: none"> Activating the digital input selects ramp pair 2. De-activating the digital input selects ramp pair 1. <p>2...5 = DI2...DI5 – Defines digital input DI2...DI5 as the control for ramp pair selection.</p> <ul style="list-style-type: none"> See DI1 above. <p>7 = COMM – Defines serial communication as the control for ramp pair selection.</p> <p>-1 = DI1(INV) – Defines an inverted digital input 1 as the control for ramp pair selection.</p> <ul style="list-style-type: none"> De-activating the digital input selects ramp pair 2 Activating the digital input selects ramp pair 1. <p>-2...-5 = DI2(INV)...DI5(INV) – Defines an inverted digital input DI2...DI5 as the control for ramp pair selection.</p> <ul style="list-style-type: none"> See DI1(INV) above. 	-5...7	1	0	
2202	<p>ACCELER TIME 1</p> <p>Sets the acceleration time for zero to maximum frequency for ramp pair 1. See A in the figure with parameter 2204 RAMP SHAPE 1.</p> <ul style="list-style-type: none"> Actual acceleration time also depends on parameter 2204 RAMP SHAPE 1. See parameter 2008 MAXIMUM FREQ. 	0.0 ... 1800.0 s	0.1 s	30.0 s	

Group 22: Accel/Decel					
Code	Description	Range	Resolution	Default	S
2203	DECELER TIME 1 Sets the deceleration time for maximum frequency to zero for ramp pair 1. <ul style="list-style-type: none"> Actual deceleration time also depends on parameter 2204 RAMP SHAPE 1. See parameter 2008 MAXIMUM FREQ. 	0.0 ... 1800.0 s	0.1 s	30.0 s	
2204	RAMP SHAPE 1 Selects the shape of the acceleration/deceleration ramp for ramp pair 1. See B in the figure. <ul style="list-style-type: none"> Shape is defined as a ramp, unless additional time is specified here to reach the maximum frequency. A longer time provides a softer transition at each end of the slope. The shape becomes an s-curve. Rule of thumb: 1/5 is a suitable relation between the ramp shape time and the acceleration ramp time. <p>0.0 = LINEAR – Specifies linear acceleration/deceleration ramps for ramp pair 1. 0.1...1000.0 – Specifies s-curve acceleration/deceleration ramps for ramp pair 1.</p>	0 ... 1000.0 s	0.1 s	0.0	<p style="text-align: center;">A = 2202 B = 2204</p>
2205	ACCELER TIME 2 Sets the acceleration time (s) for zero to maximum frequency for ramp pair 2. See parameter 2202 ACCELER TIME 1 .	0.0 ... 1800.0 s	0.1 s	60.0 s	
2206	DECELER TIME 2 Sets the deceleration time for maximum frequency to zero for ramp pair 2. See parameter 2203 DECELER TIME 1 .	0.0 ... 1800.0 s	0.1 s	60.0 s	
2207	RAMP SHAPE 2 Selects the shape of the acceleration/deceleration ramp for ramp pair 2. See parameter 2204 RAMP SHAPE 1 .	0 ... 1000.0 s	0.1 s	0.0	
2208	EMERG DEC TIME Sets the deceleration time for maximum frequency to zero for an emergency. <ul style="list-style-type: none"> See parameter 2109 EMERG STOP SEL. Ramp is linear. 	0.0 ... 1800 s	0.1 s	1.0 s	

Group 22: Accel/Decel					
Code	Description	Range	Resolution	Default	S
2209	<p>RAMP INPUT 0</p> <p>Defines control for forcing the ramp input to 0.</p> <p>0 = NOT SEL – Not selected.</p> <p>1 = DI1 – Defines digital input 1 as the control for forcing the ramp input to 0.</p> <ul style="list-style-type: none"> Activating the digital input forces ramp input to 0. Ramp output will ramp to 0 according to the currently used ramp time, after which it will stay at 0. De-activating the digital input: ramp resumes normal operation. <p>2...6 = DI2...DI6 – Defines digital input DI2...DI6 as the control for forcing the ramp input to 0.</p> <ul style="list-style-type: none"> See DI1 above. <p>7 = COMM – Defines bit 13 of the Command word 1 as the control for forcing the speed to 0.</p> <ul style="list-style-type: none"> Command word is supplied through fieldbus communication. Command word is parameter 0307. <p>-1 = DI1(INV) – Defines an inverted digital input DI1 as the control for forcing the ramp input to 0.</p> <ul style="list-style-type: none"> De-activating the digital input forces ramp input to 0. Activating the digital input: ramp resumes normal operation. <p>-2...-5 = DI2(INV)...DI5(INV) – Defines an inverted digital input DI2...DI5 as the control for forcing the ramp function generator input to 0.</p> <ul style="list-style-type: none"> See DI1(INV) above. 	-5...5	1	0	

Group 25: Critical speeds

This group defines up to three critical speeds or ranges of speeds that are to be avoided due, for example, to mechanical resonance problems at certain speeds.

Group 25: Critical speeds					
Code	Description	Range	Resolution	Default	S
2501	<p>CRIT SPEED SEL</p> <p>Sets the critical speeds function on or off. The critical speed function avoids specific speed ranges.</p> <p>0 = OFF – Disables the critical speeds function.</p> <p>1 = ON – Enables the critical speeds function.</p> <p>Example: To avoid speeds at which a fan system vibrates badly:</p> <ul style="list-style-type: none"> • Determine problem speed ranges. Assume they are found to be: 18...23 Hz and 46...52 Hz. • Set 2501 CRIT SPEED SEL = 1. • Set 2502 CRIT SPEED 1 LO = 18 Hz. • Set 2503 CRIT SPEED 1 HI = 23 Hz. • Set 2504 CRIT SPEED 2 LO = 46 Hz. • Set 2505 CRIT SPEED 2 HI = 52 Hz. 	0, 1	1	0	
2502	<p>CRIT SPEED 1 LO</p> <p>Sets the minimum limit for critical speed range 1.</p> <ul style="list-style-type: none"> • Value must be less than or equal to 2503 CRIT SPEED 1 HI. • Units are rpm. 	0.0 ... 500.0 Hz	0.1 Hz	0.0 Hz	
2503	<p>CRIT SPEED 1 HI</p> <p>Sets the maximum limit for critical speed range 1.</p> <ul style="list-style-type: none"> • Value must be greater than or equal to 2502 CRIT SPEED 1 LO. • Units are rpm. 	0.0 ... 500.0 Hz	0.1 Hz	0.0 Hz	
2504	<p>CRIT SPEED 2 LO</p> <p>Sets the minimum limit for critical speed range 2.</p> <ul style="list-style-type: none"> • See parameter 2502 CRIT SPEED 1 LO. 	0.0 ... 500.0 Hz	0.1 Hz	0.0 Hz	
2505	<p>CRIT SPEED 2 HI</p> <p>Sets the maximum limit for critical speed range 2.</p> <ul style="list-style-type: none"> • See parameter 2503 CRIT SPEED 1 HI. 	0.0 ... 500.0 Hz	0.1 Hz	0.0 Hz	
2506	<p>CRIT SPEED 3 LO</p> <p>Sets the minimum limit for critical speed range 3.</p> <ul style="list-style-type: none"> • See parameter 2502 CRIT SPEED 1 LO. 	0.0 ... 500.0 Hz	0.1 Hz	0.0 Hz	

Group 25: Critical speeds					
Code	Description	Range	Resolution	Default	S
2507	CRIT SPEED 3 HI Sets the maximum limit for critical speed range 3. • See parameter 2503 CRIT SPEED 1 HI .	0.0 ... 500.0 Hz	0.1 Hz	0.0 Hz	

■ Group 26: Motor control

This group provides controls for fine-tuning the motor control.

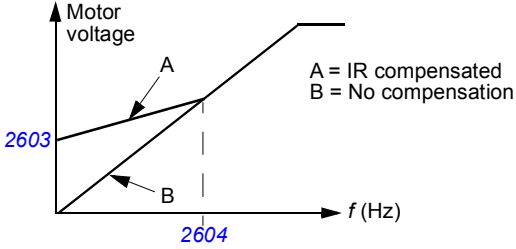
Group 26: Motor control																																			
Code	Description	Range	Resolution	Default	S																														
2603	IR COMP VOLT Sets the IR compensation voltage used for 0 Hz. • Keep IR compensation as low as possible to prevent overheating. • Typical IR compensation values are: Typical IR compensation values: <table border="1" data-bbox="400 651 797 788"> <thead> <tr> <th>P_N (kW)</th> <th>0.37</th> <th>0.75</th> <th>2.2</th> <th>4.0</th> <th>7.5</th> </tr> </thead> <tbody> <tr> <td colspan="6">200...240 V units</td> </tr> <tr> <td>IR comp (V)</td> <td>8.4</td> <td>7.7</td> <td>5.6</td> <td>8.4</td> <td>N/A</td> </tr> <tr> <td colspan="6">380...480 V units</td> </tr> <tr> <td>IR comp (V)</td> <td>14</td> <td>14</td> <td>5.6</td> <td>8.4</td> <td>7</td> </tr> </tbody> </table>  IR compensation • When enabled, IR compensation provides an extra voltage boost to the motor at low speeds. Use IR compensation, for example, in applications that require a high breakaway torque.	P_N (kW)	0.37	0.75	2.2	4.0	7.5	200...240 V units						IR comp (V)	8.4	7.7	5.6	8.4	N/A	380...480 V units						IR comp (V)	14	14	5.6	8.4	7	0 ... 100 V	1 V	0	
P_N (kW)	0.37	0.75	2.2	4.0	7.5																														
200...240 V units																																			
IR comp (V)	8.4	7.7	5.6	8.4	N/A																														
380...480 V units																																			
IR comp (V)	14	14	5.6	8.4	7																														
2604	IR COMP FREQ Sets the frequency at which IR compensation is 0 V (in % of motor frequency).	0 ... 100%	1	80%																															
2605	U/F RATIO Selects the form for the U/f (voltage to frequency) ratio below field weakening point. 1 = LINEAR – Preferred for constant torque applications. 2 = SQUARED – Preferred for centrifugal pump and fan applications. (SQUARED is more silent for most operating frequencies.)	1, 2	1	2																															

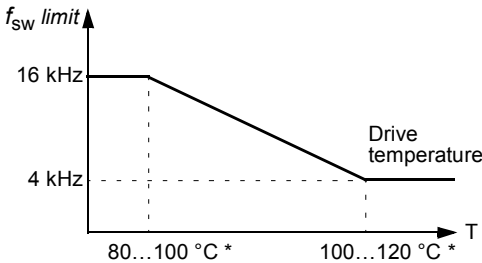
Group 26: Motor control					
Code	Description	Range	Resolution	Default	S
2606	SWITCHING FREQ Defines the switching frequency of the drive. Higher switching frequency results in lower acoustic noise in the motor. See also parameter 2207 SWITCH FREQ CTRL and section Switching frequency derating , I2N and ILD (= all currents) on page 389 . In multimotor systems, do not change the switching frequency from the default value.	1, 4, 8, 12, 16 kHz	-	4 kHz	
2607	SWITCH FREQ CTRL Activates the switching frequency control. When active, the selection of parameter 2606 SWITCHING FREQ is limited when the drive internal temperature increases. See the figure below. This function allows the highest possible switching frequency at a specific operation point. Higher switching frequency results in lower acoustic noise in the motor, but higher internal losses.	1, 2	-	1	
 <p>* Temperature depends on the drive output frequency.</p> <p>1 = ON – Active. 2 = ON (LOAD) – Switching frequency can adapt to loading instead of limiting the output current. This allows maximum loading with all switching frequency selections. The drive automatically decreases the actual switching frequency if loading is too high for the selected switching frequency.</p>					
2608	SLIP COMP RATIO Defines the slip gain for the motor slip compensation control. 100% means full slip compensation, 0% means no slip compensation. Other values can be used if a static speed error is detected despite the full slip compensation. Example: 35 Hz constant speed reference is given to the drive. Despite the full slip compensation (SLIP COMP RATIO = 100%), a manual tachometer measurement from the motor axis gives a speed value of 34 Hz. The static speed error is 35 Hz - 34 Hz = 1 Hz. To compensate the error, the slip gain should be increased. 0 = No slip compensation. 1...200 = Slip gain.	0 ... 200%	1	0	

Group 26: Motor control					
Code	Description	Range	Resolution	Default	S
2609	NOISE SMOOTHING Enables the noise smoothing function. Noise smoothing distributes the acoustic motor noise over a range of frequencies instead of a single tonal frequency resulting in lower peak noise intensity. A random component with an average of 0 Hz is added to the switching frequency set by parameter 2206 SWITCHING FREQ. Note: This parameter has no effect if parameter 2206 = 16kHz. 0 = DISABLE 1 = ENABLE	0, 1	1	0	
2610	USER DEFINED U1 Defines the first voltage point of the custom U/f curve at the frequency defined by parameter 2611 USER DEFINED F1 . See section Custom U/f ratio on page 118.	0 ... 120% of U_N V	1 = 1 V	19% of U_N	
2611	USER DEFINED F1 Defines the first frequency point of the custom U/f curve.	0.0 ... 500.0 Hz	1 = 0.1 Hz	10.0 Hz	
2612	USER DEFINED U2 Defines the second voltage point of the custom U/f curve at the frequency defined by parameter 2613 USER DEFINED F2 . See section Custom U/f ratio on page 118.	0 ... 120% of U_N V	1 = 1 V	38% of U_N	
2613	USER DEFINED F2 Defines the second frequency point of the custom U/f curve.	0.0 ... 500.0 Hz	1 = 0.1 Hz	20.0 Hz	
2614	USER DEFINED U3 Defines the third voltage point of the custom U/f curve at the frequency defined by parameter 2615 USER DEFINED F3 . See section Custom U/f ratio on page 118.	0 ... 120% of U_N V	1 = 1 V	47.5% of U_N	
2615	USER DEFINED F3 Defines the third frequency point of the custom U/f curve.	0.0 ... 500.0 Hz	1 = 0.1 Hz	25.0 Hz	
2616	USER DEFINED U4 Defines the fourth voltage point of the custom U/f curve at the frequency defined by parameter 2617 USER DEFINED F4 . See section Custom U/f ratio on page 118.	0 ... 120% of U_N V	1 = 1 V	76% of U_N	
2617	USER DEFINED F4 Defines the fourth frequency point of the custom U/f curve.	0.0 ... 500.0 Hz	1 = 0.1 Hz	40.0 Hz	
2618	FW VOLTAGE Defines the voltage of the U/f curve when frequency is equal to or exceeds the motor nominal frequency (9907 MOTOR NOM FREQ.). See section Custom U/f ratio on page 118.	0 ... 120% of U_N V	1 = 1 V	95% of U_N	
2619	DC STABILISER Enables or disables the DC voltage stabilizer. The DC stabilizer is used in scalar control mode to prevent possible voltage oscillations in the drive DC bus caused by motor load or weak supply network. In case of voltage variation the drive tunes the frequency reference to stabilize the DC bus voltage and therefore the load torque oscillation. 0 = DISABLE – Disables DC stabilizer. 1 = ENABLE – Enables DC stabilizer.				

■ Group 29: Maintenance trig

This group contains usage levels and trigger points. When usage reaches the set trigger point, a notice is displayed on the control panel signals that maintenance is due.

Group 29: Maintenance trig					
Code	Description	Range	Resolution	Default	S
2901	COOLING FAN TRIG Defines the trigger point for the drive cooling fan run time counter. Value is compared to parameter 2902 COOLING FAN ACT . • Time. If parameter value is set to zero, the trigger is disabled. 0.0 = NOT SEL	0.0 ... 6553.5 kh	0.1 kh	0.0	
2902	COOLING FAN ACT Defines the actual value for the cooling fan run time counter. When parameter 2901 COOLING FAN TRIG has been set to a non zero value, the counter starts. When the actual value of the counter exceeds the value defined by parameter 2901 , a maintenance notice is displayed on the panel. • Time. Parameter is reset by writing 0.0 to it.	0.0 ... 6553.5 kh	0.1 kh	0.0	
2903	REVOLUTION TRIG Defines the trigger point for the motor revolution counter. Value is compared to parameter 2904 REVOLUTION ACT value. • Millions of revolutions. If parameter value is set to zero, the trigger is disabled. 0.0 = NOT SEL	0 ... 65535 MRev	1 MRev	0	
2904	REVOLUTION ACT Defines the actual value for the motor revolution counter. When parameter 2903 REVOLUTION TRIG has been set to a non zero value, the counter starts. When the actual value of the counter exceeds the value defined by parameter 2903 , a maintenance notice is displayed on the panel. • Millions of revolutions. Parameter is reset by setting it to zero.	0 ... 65535 MRev	1 MRev	0	
2905	RUN TIME TRIG Defines the trigger point for the drive run time counter. Value is compared to the value of parameter 2906 RUN TIME ACT . • Time. If parameter value is set to zero, the trigger is disabled. 0.0 = NOT SEL	0.0 ... 6553.5 kh	0.1 kh	0.0	
2906	RUN TIME ACT Defines the actual value for the drive run time counter. When parameter 2905 RUN TIME TRIG has been set to a non zero value, the counter starts. When the actual value of the counter exceeds the value defined by parameter 2905 , a maintenance notice is displayed on the panel. • Time. Parameter is reset by setting it to zero.	0.0 ... 6553.5 kh	0.1 kh	0.0	

Group 29: Maintenance trig					
Code	Description	Range	Resolution	Default	S
2907	USER MWh TRIG Defines the trigger point for the drive power consumption counter. Value is compared to the value of parameter 2908 USER MWh ACT . • Megawatt hours. If parameter value is set to zero, the trigger is disabled. 0.0 = NOT SEL	0.0 ... 6553.5 MWh	0.1 MWh	0.0	
2908	USER MWh ACT Defines the actual value of the drive power consumption counter. When parameter 2907 USER MWh TRIG has been set to a non zero value, the counter starts. When the actual value of the counter exceeds the value defined by parameter 2907 , a maintenance notice is displayed on the panel. • Megawatt hours. Parameter is reset by setting it to zero.	0.0 ... 6553.5 MWh	0.1 MWh	0.0	

■ Group 30: Fault functions

This group defines situations that the drive should recognize as potential faults and defines how the drive should respond if the fault is detected.

Group 30: Fault functions					
Code	Description	Range	Resolution	Default	S
3001	AI<MIN FUNCTION Defines the drive response if the analog input (AI) signal drops below the fault limits and is used: • as the active reference source (Group 11: Reference select) • as the Process or External PID controllers' feedback or setpoint source (Group 40: Process PID set 1 , Group 41: Process PID set 2 or Group 42: Ext / Trim PID) and the corresponding PID controller is active. 3021 AI1 FAULT LIMIT and 3022 AI2 FAULT LIMIT set the minimum limits. 0 = NOT SEL – No response. 1 = FAULT – Displays a fault (0007 AI1 LOSS or 0008 AI2 LOSS) and the drive coasts to a stop. 2 = CONST SP 7 – Displays a warning (2006 AI1 LOSS or 2007 AI2 LOSS) and sets speed using 1208 CONST SPEED 7 . 3 = LAST SPEED – Displays a warning (2006 AI1 LOSS or 2007 AI2 LOSS) and sets speed using the last operating level. This value is the average speed over the last 10 seconds.  WARNING! If you select CONST SP7 or LAST SPEED, make sure that continued operation is safe when the analog input signal is lost.	0...3	1	0	

Group 30: Fault functions					
Code	Description	Range	Resolution	Default	S
3002	<p>PANEL COMM ERR</p> <p>Defines the drive response to a control panel communication error.</p> <p>Note: When either of the two external control locations are active, and start, stop and/or direction are through the control panel – <i>1001 EXT1 COMMANDS / 1002 EXT2 COMMANDS</i> = 8 (KEYPAD) – the drive follows the speed reference according to the configuration of the external control locations, instead of the value of the last speed or parameter <i>1208 CONST SPEED 7</i>.</p> <p>1 = FAULT – Displays a fault (10, PANEL LOSS) and the drive coasts to stop.</p> <p>2 = CONST SP 7 – Displays a warning <i>2008 PANEL LOSS</i> and sets speed using <i>1208 CONST SPEED 7</i>.</p> <p>3 = LAST SPEED – Displays a warning <i>2008 PANEL LOSS</i> and sets speed using the last operating level. This value is the average speed over the last 10 seconds.</p> <p> WARNING! If you select CONST SP7 or LAST SPEED, make sure that continued operation is safe when the control panel communication is lost.</p>	1...3	1	1	
3003	<p>EXTERNAL FAULT 1</p> <p>Defines the External Fault 1 signal input and the drive response to an external fault.</p> <p>0 = NOT SEL – External fault signal is not used.</p> <p>1 = DI1 – Defines digital input 1 as the external fault input.</p> <ul style="list-style-type: none"> Activating the digital input indicates a fault. The drive displays fault <i>0014 EXT FAULT 1</i> and the drive coasts to stop. <p>2...5 = DI2...DI5 – Defines digital input DI2...DI5 as the external fault input.</p> <ul style="list-style-type: none"> See DI1 above. <p>-1 = DI1(INV) – Defines an inverted digital input 1 as the external fault input.</p> <ul style="list-style-type: none"> De-activating the digital input indicates a fault. The drive displays fault <i>0014 EXT FAULT 1</i> and the drive coasts to stop. <p>-2...-5 = DI2(INV)...DI5(INV) – Defines an inverted digital input DI2...DI5 as the external fault input.</p> <ul style="list-style-type: none"> See DI1(INV) above. 	-5...5	1	0	
3004	<p>EXTERNAL FAULT 2</p> <p>Defines the External fault 2 signal input and the drive response to an external fault.</p> <ul style="list-style-type: none"> See parameter <i>3003 EXTERNAL FAULT 1</i> above. 	-5...5	1	0	
3005	<p>MOT THERM PROT</p> <p>Defines the drive response to motor overheating.</p> <p>0 = NOT SEL – No response and/or motor thermal protection not set up.</p> <p>1 = FAULT – When the calculated motor temperature exceeds 90 °C (194 °F), displays alarm <i>2010 MOTOR TEMP</i>. When the calculated motor temperature exceeds 110 °C (230 °F) displays fault <i>0009 MOT OVERTEMP</i> and the drive coasts to stop.</p> <p>Note: Because the motor thermal protection has memory retention, do not shut down the drive when fault <i>0009 MOT OVERTEMP</i> occurs. If you shut down the drive, the drive does not reset the fault. The drive resets the fault as soon as the motor temperature has lowered enough.</p> <p>2 = ALARM – When the calculated motor temperature exceeds 90 °C (194 °F), displays alarm <i>2010 MOTOR TEMP</i>.</p>	0, 2	1	1	

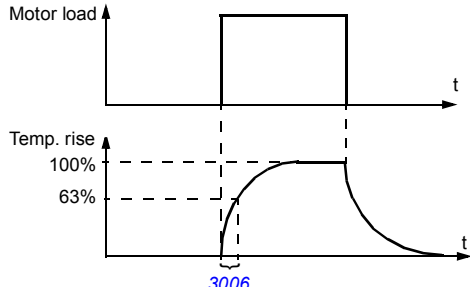
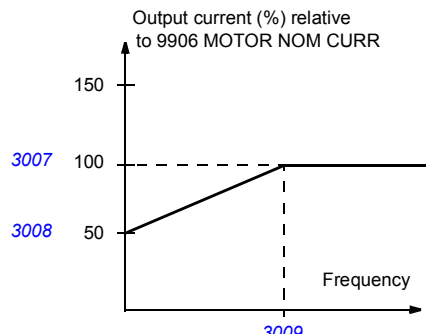
Group 30: Fault functions					
Code	Description	Range	Resolution	Default	S
3006	<p>MOT THERM TIME</p> <p>Sets the motor thermal time constant for the motor temperature model.</p> <ul style="list-style-type: none"> This is the time required for the motor to reach 63% of the final temperature with steady load. For thermal protection according to UL requirements for NEMA class motors, use the rule of thumb: MOTOR THERM TIME equals 35 times t_6, where t_6 (in seconds) is specified by the motor manufacturer as the time that the motor can safely operate at six times its rated current. The thermal time for a Class 10 trip curve is 350 s, for a Class 20 trip curve 700 s, and for a Class 30 trip curve 1050 s. 	256 ... 9999 s	1	1050 s	
3007	<p>MOT LOAD CURVE</p> <p>Sets the maximum allowable operating load of the motor.</p> <ul style="list-style-type: none"> With the default value 100%, motor overload protection is functioning when the constant current exceeds 127% of the parameter 9906 MOTOR NOM CURR value. The default overloadability is at the same level as what motor manufacturer's typically allow in the 30 °C (86 °F) ambient temperature and 1000m (3300 ft) altitude. When the ambient temperature exceeds 30 °C (86 °F) or the installation altitude is over 1000m (3300 ft), decrease the parameter 3007 value according to the motor manufacturer's recommendation. <p>Example: If the constant protection level needs to be 115% of the motor nominal current, set parameter 3007 MOT LOAD CURVE value to 91% ($=115/127*100\%$).</p>	50 ... 150%	1	100%	
3008	<p>ZERO SPEED LOAD</p> <p>Defines the load curve together with parameters 3007 MOT LOAD CURVE and 3009 BREAK POINT FREQ.</p> <p>25%...150% = Allowed continuous motor load at zero speed in percent of the nominal motor current.</p>	25 ... 150%	1	70%	

Group 30: Fault functions

Code	Description	Range	Resolution	Default	S
3009	<p>BREAK POINT FREQ</p> <p>Defines the load curve together with parameters 3007 MOT LOAD CURVE and 3009 BREAK POINT FREQ.</p> <p>Example: Thermal protection trip times when parameters 3006 MOT THERM TIME, 3007 MOT LOAD CURVE and 3008 ZERO SPEED LOAD have default values.</p> <p>I_O/I_N</p> <p>f_O/f_{BRK}</p> <p>60 s 90 s 180 s 300 s 600 s ∞</p> <p>I_O = Output current I_N = Nominal motor current f_O = Output frequency f_{BRK} = Break point frequency A = Trip time</p>	1 ... 250 Hz	1	35 Hz	
3010	<p>STALL FUNCTION</p> <p>Selects how the drive reacts to a motor stall condition. The protection wakes up if the drive has operated in a stall region (see the figure below) longer than the time set by parameter 3012 STALL TIME.</p> <p>Current (A)</p> <p>Stall region</p> <p>0.95 · User defined limit</p> <p>User defined limit = 2003 MAX CURRENT</p> <p>f</p> <p>Par. 3011</p> <p>0 = NOT SEL – Protection is inactive. 1 = FAULT – Drive trips on fault 0012 MOTOR STALL and the motor coasts to stop. 2 = ALARM – Drive generates alarm 2012 MOTOR STALL.</p>	0...2	1	0 Hz	
3011	<p>STALL FREQUENCY</p> <p>This parameter sets the frequency value for the Stall function. Refer to the figure above.</p>	0.5 ... 50.0 Hz	0.1 Hz	20.0 Hz	
3012	<p>STALL TIME</p> <p>This parameter sets the time value for the Stall function.</p>	10 ... 400 s	1 s	20 s	

Group 30: Fault functions					
Code	Description	Range	Resolution	Default	S
3016	<p>SUPPLY PHASE</p> <p>Selects how the drive reacts to a supply phase loss, in other words, when the DC voltage ripple is excessive.</p> <p>0 = FAULT – Drive trips on fault <i>SUPPLY PHASE</i> and the motor coasts to stop when the DC voltage ripple exceeds 14% of the nominal DC voltage.</p> <p>1 = LIMIT/ALARM – Drive output current is limited and alarm <i>INPUT PHASE LOSS</i> is generated when the DC voltage ripple exceeds 14% of the nominal DC voltage. There is a 10 s delay between the activation of the alarm and the output current limitation. The current is limited until the DC voltage ripple drops under the ripple limit.</p> <p>2 = ALARM – Drive generates alarm <i>INPUT PHASE LOSS</i> when the DC ripple exceeds 14% of the nominal DC voltage.</p>				
3017	<p>EARTH FAULT</p> <p>Defines the drive response if the drive detects a ground fault in the motor or motor cables. The drive monitors for ground faults while the drive is running, and while the drive is not running. Also see parameter <i>3023 WIRING FAULT</i>.</p> <p>0 = DISABLE – No drive response to ground faults.</p> <p>1 = ENABLE – Ground faults display fault <i>0016 EARTH FAULT</i>, and (if running) the drive coasts to stop.</p>	0...1	1	1	
3018	<p>COMM FAULT FUNC</p> <p>Defines the drive response if the fieldbus communication is lost. The time delay is defined by parameter <i>3019 COMM FAULT TIME</i>.</p> <p>0 = NOT SEL – No response.</p> <p>1 = FAULT – Displays fault <i>0028 SERIAL 1 ERR</i> and the drive coasts to stop.</p> <p>2 = CONST SP 7 – Displays warning <i>2005 IO COMM</i> and sets speed using parameter <i>1208 CONST SPEED 7</i>. This “alarm speed” remains active until the fieldbus writes a new reference value.</p> <p>3 = LAST SPEED – Displays warning <i>2005 IO COMM</i> and sets speed using the last operating level. This value is the average speed over the last 10 seconds. This “alarm speed” remains active until the fieldbus writes a new reference value.</p> <p> WARNING! If you select CONST SP7, or LAST SPEED, make sure that continued operation is safe when fieldbus communication is lost.</p>	0...3	1	0	
3019	<p>COMM FAULT TIME</p> <p>Sets the communication fault time used with parameter <i>3018 COMM FAULT FUNC</i>.</p> <ul style="list-style-type: none"> • Brief interruptions in the fieldbus communication are not treated as faults if they are less than the COMM FAULT TIME value. 	0.0 ... 600.0 s	0.1 s	10.0 s	
3021	<p>AI1 FAULT LIMIT</p> <p>Sets a fault level for analog input 1. See parameter <i>3001 AI<MIN> FUNCTION</i>. Do not set this limit below the level defined by parameter <i>1301 MINIMUM AI1</i>.</p> <ul style="list-style-type: none"> • Value in percent of the full signal range. 	0.0 ... 100.0%	0.1%	0.0%	
3022	<p>AI2 FAULT LIMIT</p> <p>Sets a fault level for analog input 2. See parameter <i>3001 AI<MIN> FUNCTION</i>. Do not set this limit below the level defined by parameter <i>1304 MINIMUM AI2</i>.</p> <ul style="list-style-type: none"> • Value in percent of the full signal range. 	0.0 ... 100.0%	0.1%	0.0%	

Group 30: Fault functions					
Code	Description	Range	Resolution	Default	S
3023	WIRING FAULT Selects how the drive reacts when incorrect input power and motor cable connection is detected (ie, the input power cable is connected to the motor connection of the drive). 0 = DISABLE – No action. 1 = ENABLE – The drive trips on fault <i>0035 OUTP WIRING</i> .	0, 1	1	1	
3027	OPTION COM LOSS Selects how the drive reacts when the MREL-01 output relay module is removed from the drive, and parameters <i>1402 RELAY OUTPUT 2</i> , <i>1403 RELAY OUTPUT 3</i> or <i>1410 RELAY OUTPUT 4</i> have non-zero values. 0 = DISABLE – Prevents the fault 1006 PAR EXT RO even when MREL-01 is disconnected. 1 = ENABLE – MREL-01 is constantly monitored for disconnection. The drive trips on fault 1006 PAR EXT RO if external relay outputs are configured for use.	0, 1	1	1	

■ Group 31: Automatic reset

This group defines conditions for automatic resets. An automatic reset occurs after a particular fault is detected. The drive holds for a set delay time, then automatically restarts. You can limit the number of resets in a specified time period, and you can set up automatic resets for a variety of faults.

Group 31: Automatic reset					
Code	Description	Range	Resolution	Default	S
3101	NUMBER OF TRIALS Sets the number of allowed automatic resets within a trial period defined by parameter <i>3102 TRIAL TIME</i> . <ul style="list-style-type: none"> If the number of automatic resets exceeds this limit (within the trial time), the drive prevents additional automatic resets and remains stopped. Starting then requires a successful reset performed from the control panel or from a source selected by parameter <i>1604 FAULT RESET SEL</i>. <p>Example: Three faults have occurred in the trial time. The last is reset only if the value for parameter <i>3101 NUMBER OF TRIALS</i> is 3 or more.</p>	0...5	1	5	
3102	TRIAL TIME Sets the time period used for counting and limiting the number of resets. <ul style="list-style-type: none"> See parameter <i>3101 NUMBER OF TRIALS</i>. 	1.0 ... 600.0 s	0.1 s	30.0 s	
3103	DELAY TIME Sets the delay time between a fault detection and attempted drive restart. <ul style="list-style-type: none"> If DELAY TIME = zero, the drive resets immediately. 	0.0 ... 120.0 s	0.0 s	6.0 s	

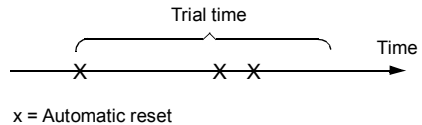

Group 31: Automatic reset					
Code	Description	Range	Resolution	Default	S
3104	AR OVERCURRENT Sets the automatic reset for the overcurrent function on or off. 0 = DISABLE – Disables automatic reset. 1 = ENABLE – Enables automatic reset. <ul style="list-style-type: none"> Automatically resets fault 0001 OVERCURRENT after the delay set by parameter 3103 DELAY TIME, and the drive resumes normal operation. 	0, 1	1	0	
3105	AR OVERVOLTAGE Sets the automatic reset for the intermediate link overvoltage function on or off. 0 = DISABLE – Disables automatic reset. 1 = ENABLE – Enables automatic reset. <ul style="list-style-type: none"> Automatically resets fault 0002 DC OVERVOLT after the delay set by parameter 3103 DELAY TIME, and the drive resumes normal operation. 	0, 1	1	1	
3106	AR UNDERVOLTAGE Sets the automatic reset for the intermediate link undervoltage function on or off. 0 = DISABLE – Disables automatic reset. 1 = ENABLE – Enables automatic reset. <ul style="list-style-type: none"> Automatically resets the fault 0006 DC UNDERVOLT after the delay set by parameter 3103 DELAY TIME, and the drive resumes normal operation. 	0, 1	1	1	
3107	AR AI<MIN Sets the automatic reset for the analog input less than minimum value function on or off. 0 = DISABLE – Disables automatic reset. 1 = ENABLE – Enables automatic reset. <ul style="list-style-type: none"> Automatically resets fault faults 0007 AI1 LOSS and 0008 AI2 LOSS after the delay set by parameter 3103 DELAY TIME, and the drive resumes normal operation. <p> WARNING! When the analog input signal is restored, the drive may restart, even after a long stop. Make sure that automatic, long delayed starts will not cause physical injury and/or damage equipment.</p>	0, 1	1	1	
3108	AR EXTERNAL FLT Sets the automatic reset for external faults function on or off. 0 = DISABLE – Disables automatic reset. 1 = ENABLE – Enables automatic reset. <ul style="list-style-type: none"> Automatically resets the fault (0014 EXT FAULT 1 or 0015 EXT FAULT 2) after the delay set by parameter 3103 DELAY TIME, and the drive resumes normal operation. 	0, 1	1	1	

■ Group 32: Supervision

This group defines supervision for up to three signals from [Group 01: Operating data](#). Supervision monitors a specified parameter and energizes a relay output if the parameter passes a defined limit. Use [Group 14: Relay outputs](#), to define the relay and whether the relay activates when the signal is too low or too high.

Group 32: Supervision					
Code	Description	Range	Resolution	Default	S
3201	<p>SUPERV 1 PARAM</p> <p>Selects the first supervised parameter.</p> <ul style="list-style-type: none"> • Must be a parameter number from Group 01: Operating data. • If the supervised parameter passes a limit, a relay output is energized. • The supervision limits are defined in this group. • The relay outputs are defined in Group 14: Relay outputs (definition also specifies which supervision limit is monitored). <p>LO ≤ HI</p> <p>Operating data supervision using relay outputs, when LO ≤ HI.</p> <ul style="list-style-type: none"> • Case A = Parameter 1401 RELAY OUTPUT 1 (or 1402 RELAY OUTPUT 2, etc.) value is SUPRV1 OVER or SUPRV 2 OVER. Use for monitoring when/if the supervised signal exceeds a given limit. The relay remains active until the supervised value drops below the low limit. • Case B = Parameter 1401 RELAY OUTPUT 1 (or 1402 RELAY OUTPUT 2, etc.) value is SUPRV 1 UNDER or SUPRV 2 UNDER. Use for monitoring when/if the supervised value falls below a given limit. The relay remains active until the supervised value rises above the high limit. <p>Note: Case LO ≤ HI represents a normal hysteresis.</p>	101...178	1	103	

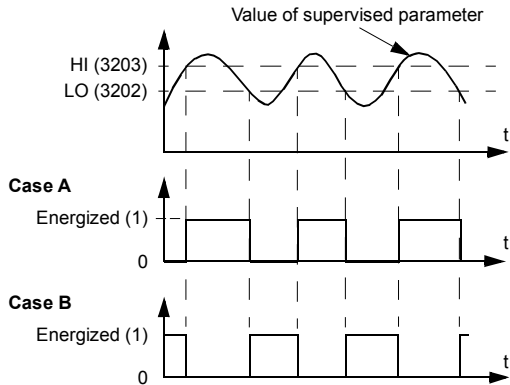

Group 32: Supervision					
Code	Description	Range	Resolution	Default	S
	<p>LO > HI</p> <p>Operating data supervision using relay outputs, when LO > HI. The lowest limit (HI 3203) is active initially, and remains active until the supervised parameter goes above the highest limit (LO 3202), making that limit the active limit. That limit remains active until the supervised parameter goes below the lowest limit (HI 3203), making that limit active.</p> <ul style="list-style-type: none"> • Case A = Parameter 1401 RELAY OUTPUT 1 (or 1402 RELAY OUTPUT 2, etc.) value is SUPRV1 OVER or SUPRV2 OVER. Initially the relay is de-energized. It is energized whenever the supervised parameter goes above the active limit. • Case B = Parameter 1401 RELAY OUTPUT 1 (or 1402 RELAY OUTPUT 2, etc.) value is SUPRV1 UNDER or SUPRV2 UNDER. Initially the relay is energized. It is de-energized whenever the supervised parameter goes below the active limit. <p>Note: Case LO > HI represents a special hysteresis with two separate supervision limits.</p>				
3202	SUPERV 1 LIM LO	Depends on selection	-	60.0	
	Sets the low limit for the first supervised parameter. See parameter 3201 SUPERV 1 PARAM above. Supervision wakes up if the value is below the limit.				
3203	SUPERV 1 LIM HI	Depends on selection	-	60.0	
	Sets the high limit for the first supervised parameter. See parameter 3201 SUPERV 1 PARAM above. Supervision wakes up if the value is above the limit.				
3204	SUPERV 2 PARAM	101...178	1	104	
	Selects the second supervised parameter. See parameter 3201 SUPERV 1 PARAM above.				
3205	SUPERV 2 LIM LO	Depends on selection		4.5	
	Sets the low limit for the second supervised parameter. See parameter 3204 SUPERV 2 PARAM above. Supervision wakes up if the value is below the limit.				
3206	SUPERV 2 LIM HI	Depends on selection		4.5	
	Sets the high limit for the second supervised parameter. See parameter 3204 SUPERV 2 PARAM above. Supervision wakes up if the value is above the limit.				
3207	SUPERV 3 PARAM	101...178	1	105	
	Selects the third supervised parameter. See parameter 3201 SUPERV 1 PARAM above.				

Group 32: Supervision					
Code	Description	Range	Resolution	Default	S
3208	SUPERV 3 LIM LO Sets the low limit for the third supervised parameter. See parameter 3207 SUPERV 3 PARAM above. Supervision wakes up if the value is below the limit.	Depends on selection		100.0	
3209	SUPERV 3 LIM HI Sets the high limit for the third supervised parameter. See parameter 3207 SUPERV 3 PARAM above. Supervision wakes up if the value is above the limit.	Depends on selection		100.0	

■ Group 33: Information

This group provides access to information about the drive's current programs: versions and test date.

Group 33: Information					
Code	Description	Range	Resolution	Default	S
3301	FIRMWARE Contains the version of the drive's firmware.	10000...FFFF hex	1	Firmware ver.	
3302	LOADING PACKAGE Contains the version of the loading package.	0000...FFFF hex	1	0	
3303	TEST DATE Contains the test date (yy.ww).	yy.ww	1	0	
3304	DRIVE RATING Indicates the drive's current and voltage rating. The format is XXXY hex, where: <ul style="list-style-type: none"> • XXX = The nominal current rating of the drive in amps. If present, an "A" indicates a decimal point in the rating for the current. For example XXX = 9A8 indicates a nominal current rating of 9.8 amperes. • Y = The voltage rating of the drive, where Y = : <ul style="list-style-type: none"> • 2 indicates a 200...240 Volt rating. • 4 indicates a 380...480 Volt rating. • 6 indicates a 500...600 Volt rating. 	-	-	-	
3305	PARAMETER TABLE Contains the parameter table version of the drive's firmware.	0000...FFFF hex			

■ Group 34: Panel display

This group defines the content for control panel display (middle area), when the control panel is in the Output mode.

Group 34: Panel display					
Code	Description	Range	Resolution	Default	S
3401	<p>SIGNAL1 PARAM</p> <p>Selects the first parameter (by number) displayed on the control panel.</p> <ul style="list-style-type: none"> Definitions in this group define display content when the control panel is in the Output mode. Any <i>Group 01: Operating data</i> parameter number can be selected. Using the following parameters, the display value can be scaled, converted to convenient units, and/or displayed as a bar graph. The figure identifies selections made by parameters in this group. <p>100 = not selected – First parameter not displayed. 101...199 = Displays parameter 0101...0199. If parameter does not exist, the display shows "n.a."</p>	101...178	1	103	
3402	<p>SIGNAL1 MIN</p> <p>Defines the minimum expected value for the first display parameter.</p> <p>Use parameters 3402, 3403, 3406, and 3407, for example to convert a Group 01 parameter, such as 0102 SPEED (in rpm) to the speed of a conveyor driven by the motor (in ft/min). For such a conversion, the source values in the figure are the min. and max. motor speed, and the display values are the corresponding min. and max. conveyor speed. Use parameter 3405 to select the proper units for the display.</p> <p>Note: Selecting units does not convert values.</p>	Depends on selection		0.0	
3403	<p>SIGNAL1 MAX</p> <p>Defines the maximum expected value for the first display parameter.</p> <p>Note: Parameter is not effective if parameter 3404 OUTPUT1 DSP FORM = 9 (DIRECT).</p>	Depends on selection	-	600.0	

Group 34: Panel display					
Code	Description	Range	Resolution	Default	S
3407	OUTPUT1 MAX Sets the maximum value displayed for the first display parameter. Note: Parameter is not effective if parameter 3404 OUTPUT1 DSP FORM = 9 (DIRECT).	Depends on selection	1	-	
3408	SIGNAL2 PARAM Selects the second parameter (by number) displayed on the control panel. See parameter 3401 SIGNAL1 PARAM .	100...178	1	104	
3409	SIGNAL2 MIN Defines the minimum expected value for the second display parameter. See parameter 3402 SIGNAL1 MIN .	Depends on selection	1	-	
3410	SIGNAL2 MAX Defines the maximum expected value for the second display parameter. See parameter 3403 SIGNAL1 MAX .	Depends on selection	1	-	
3411	OUTPUT2 DSP FORM Defines the decimal point location for the second display parameter. See parameter 3404 OUTPUT1 DSP FORM .	0...9	1	-	
3412	OUTPUT2 UNIT Selects the units used with the second display parameter. See parameter 3405 OUTPUT1 UNIT .	0...127	1	1	
3413	OUTPUT2 MIN Sets the minimum value displayed for the second display parameter. See parameter 3406 OUTPUT1 MIN .	Depends on selection	1	-	
3414	OUTPUT2 MAX Sets the maximum value displayed for the second display parameter. See parameter 3407 OUTPUT1 MAX .	Depends on selection	1	-	
3415	SIGNAL3 PARAM Selects the third parameter (by number) displayed on the control panel. See parameter 3401 SIGNAL1 PARAM .	100...178	1	120	
3416	SIGNAL3 MIN Defines the minimum expected value for the third display parameter. See parameter 3402 SIGNAL1 MIN .	Depends on selection	1	-	
3417	SIGNAL3 MAX Defines the maximum expected value for the third display parameter. See parameter 3403 SIGNAL1 MAX .	Depends on selection	1	-	
3418	OUTPUT 3 DSP FORM Defines the decimal point location for the third display parameter. See parameter 3404 OUTPUT1 DSP FORM .	0...9	1	5	

Group 34: Panel display					
Code	Description	Range	Resolution	Default	S
3419	OUTPUT3 UNIT Selects the units used with the third display parameter. See parameter 3405 OUTPUT1 UNIT .	0...127	1	11	
3420	OUTPUT3 MIN Sets the minimum value displayed for the third display parameter. See parameter 3406 OUTPUT1 MIN .	Depends on selection	1	-	
3421	OUTPUT3 MAX Sets the maximum value displayed for the third display parameter. See parameter 3407 OUTPUT1 MAX .	Depends on selection	1	-	

Group 35: Motor temp meas

Group 35: Motor temp meas											
Code	Description	Range	Resolution	Default	S						
3501	<p>SENSOR TYPE</p> <p>Activates the motor temperature measurement function and selects the sensor type. See also parameter Group 15: Analogue outputs.</p> <p>0 = NONE – Function is inactive.</p> <p>1 = 1 x PT100 – Function is active. The temperature is measured with one Pt100 sensor. Analog output AO feeds constant current through the sensor. The sensor resistance increases as the motor temperature rises, as does the voltage over the sensor. The temperature measurement function reads the voltage through analog input AI1/2 and converts it to degrees centigrade.</p> <p>2 = 2 x PT100 – Function is active. The temperature is measured using two Pt100 sensors. See selection 1 x PT100 above.</p> <p>3 = 3 x PT100 – Function is active. The temperature is measured using three Pt100 sensors. See selection 1 x PT100 above.</p> <p>4 = PTC – Function is active. The temperature is supervised using one PTC sensor. Analog output AO feeds constant current through the sensor. The resistance of the sensor increases sharply as the motor temperature rises over the PTC reference temperature (Tref), as does the voltage over the resistor. The temperature measurement function reads the voltage through analog input AI1/2 and converts it into ohms. The figure on the right-hand side shows typical PTC sensor resistance values as a function of the motor operating temperature.</p> <table border="1"> <thead> <tr> <th>Temperature</th> <th>Resistance</th> </tr> </thead> <tbody> <tr> <td>Normal</td> <td>0 ... 1.5 kohm</td> </tr> <tr> <td>Excessive</td> <td>≥ 4 kohm</td> </tr> </tbody> </table>	Temperature	Resistance	Normal	0 ... 1.5 kohm	Excessive	≥ 4 kohm	0..6	1	0	
Temperature	Resistance										
Normal	0 ... 1.5 kohm										
Excessive	≥ 4 kohm										
	<p>5 = THERM (0) – Function is active. The motor temperature is monitored using a PTC sensor (see selection PTC) connected to a drive through a normally closed thermistor relay connected to a digital input. 0 = motor overtemperature.</p> <p>6 = THERM (1) – Function is active. The motor temperature is monitored using a PTC sensor (see selection PTC) connected to a drive through a normally open thermistor relay connected to a digital input. 1 = motor overtemperature.</p> <p>See the figures in section Motor temperature measurement through the standard I/O.</p>										

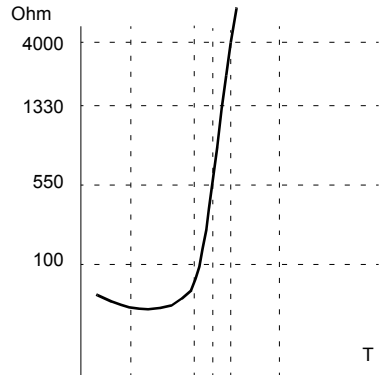

Group 35: Motor temp meas					
Code	Description	Range	Resolution	Default	S
3502	INPUT SELECTION Selects the source for the motor temperature measurement signal. 1 = AI1 – Analog input AI1. Used when Pt100 or PTC sensor is selected for the temperature measurement. 2 = AI2 – Analog input AI2. Used when Pt100 or PTC sensor is selected for the temperature measurement. 3 = DI1 – Digital input DI1. Used when the value of parameter <i>3501 SENSOR TYPE</i> is set to THERM(0)/THERM(1). 4 = DI2 – Digital input DI2. Used when parameter <i>3501 SENSOR TYPE</i> value is set to THERM(0)/THERM(1). 5 = DI3 – Digital input DI3. Used when parameter <i>3501 SENSOR TYPE</i> value is set to THERM(0)/THERM(1). 6 = DI4 – Digital input DI4. Used when parameter <i>3501 SENSOR TYPE</i> value is set to THERM(0)/THERM(1). 7 = DI5 – Digital input DI5. Used when parameter <i>3501 SENSOR TYPE</i> value is set to THERM(0)/THERM(1).	1...7	1	1	
3503	ALARM LIMIT Defines the alarm limit for motor temperature measurement. Alarm <i>2010 MOTOR TEMP</i> indication is given when the limit is exceeded. When parameter <i>3501 SENSOR TYPE</i> value is set to THERM(0)/THERM(1): 1 = alarm.	Depends on sensor	1	0	
3504	FAULT LIMIT Defines the fault trip limit for motor temperature measurement. The drive trips on fault <i>0009 MOT OVERTEMP</i> when the limit is exceeded. When parameter <i>3501 SENSOR TYPE</i> value is set to THERM(0)/THERM(1): 1 = fault.	Depends on sensor	1	0	
3505	AO EXCITATION Enables current feed from analog output AO. The parameter setting overrides the settings in <i>Group 15: Analogue outputs</i> . <ul style="list-style-type: none"> • With PTC the output current is 1.6 mA. • With Pt 100 the output current is 9.1 mA. 0 = DISABLE 1 = ENABLE			0	

■ Group 36: Timed functions

This group defines the timed functions. The timed functions include:

- four daily start and stop times
- four weekly start, stop and boost times
- four timers for collecting selected periods together.

A timer can be connected to multiple time periods and a time period can be in multiple timers.

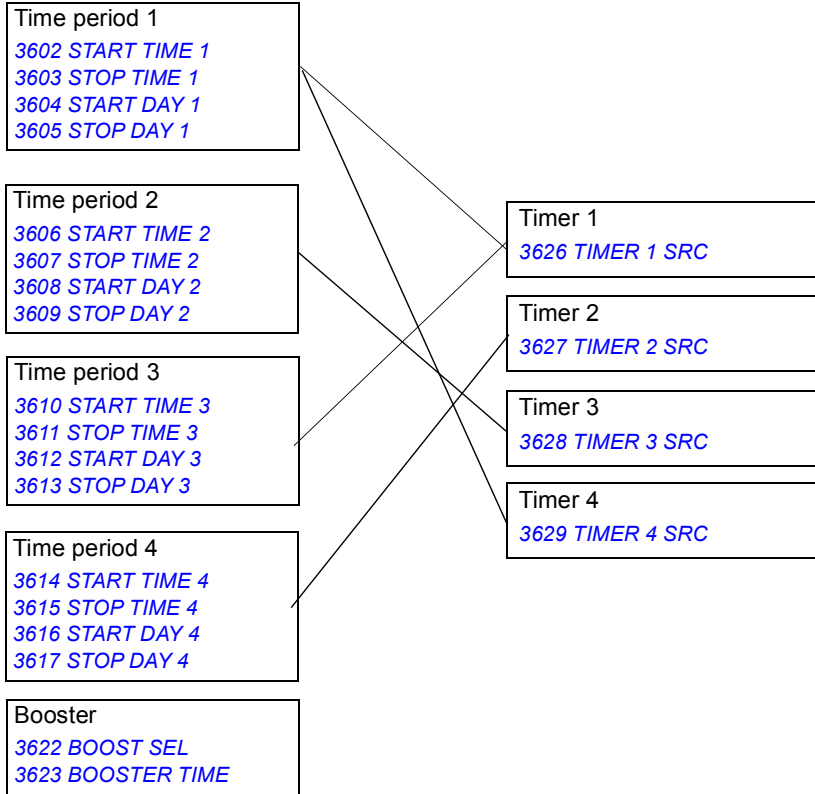

A parameter can be connected to only one timer.

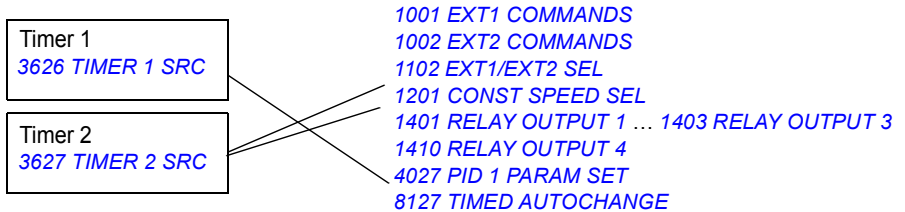

Group 36: Timed functions					
Code	Description	Range	Resolution	Default	S
3601	<p>TIMERS ENABLE</p> <p>Selects the source for the timer enable signal.</p> <p>0 = NOT SEL – Timed functions are disabled.</p> <p>1 = DI1 – Defines digital input DI1 as the timed function enable signal.</p> <ul style="list-style-type: none"> • The digital input must be activated for timed functions enable. <p>2...5 = DI2...DI5 – Defines digital input DI2...DI5 as the timed function enable signal.</p> <p>7 = ACTIVE – Timed functions are enabled.</p> <p>11...15 = DI1 CMODE...DI5 CMODE – Timed function enabled on the rising edge of DI1. Timed function is in a continuous mode, in which the start date can be different from the stop date.</p> <p>17 = CONT MODE – Timed function enabled in a continuous mode, in which the start date can be different from the stop date.</p> <p>-1 = DI1(INV) – Defines an inverted digital input DI1 as the timed function enable signal.</p> <ul style="list-style-type: none"> • This digital input must be de-activated for timed function enable. <p>-2...-5 = DI2(INV)...DI5(INV) – Defines an inverted digital input DI2...DI5 as the timed function enable signal.</p> <p>-11...-15 = DI1(INV) CM...DI5(INV) CM – Timed function enabled on the falling edge of DI1. Timed function is in a continuous mode, in which the start date can be different from the stop date.</p>	-15...17	1	0	S
3602	<p>START TIME 1</p> <p>Defines the daily start time.</p> <ul style="list-style-type: none"> • The time can be changed in steps of 2 seconds. • If parameter value is 07:00:00, then the period will be activated at 7 a.m. • The figure shows multiple periods on different weekdays. <p>When editing parameters to set times:</p> <ul style="list-style-type: none"> • Use arrow keys to select desired hour setting. • Press NEXT to advance to minutes. • Use arrow keys to select desired minutes setting. • Press NEXT to advance to minutes. • Use arrow keys to select desired seconds setting. • Press SAVE. 	00:00:00 ... 23:59:58	2 s	12:00:00	S
3603	<p>STOP TIME 1</p> <p>Defines the daily stop time.</p> <ul style="list-style-type: none"> • The time can be changed in steps of 2 seconds. • If the parameter value is 09:00:00, then the period will be deactivated at 9 a.m. 	00:00:00 ... 23:59:58	2 s	12:00:00	S

Group 36: Timed functions					
Code	Description	Range	Resolution	Default	S
3604	START DAY 1 Defines the weekly start day. 1 = MONDAY...7 = SUNDAY. <ul style="list-style-type: none"> If parameter value is 1, then period 1 weekly is active from Monday midnight (00:00:00). 	1...7	1	1	
3605	STOP DAY 1 Defines weekly stop day. 1 = MONDAY...7 = SUNDAY. <ul style="list-style-type: none"> If parameter value is 5, then timer 1 weekly will be deactivated on Friday midnight (23:59:58). 	1...7	1	1	
3606	START TIME 2 Defines timer 2 daily start time. <ul style="list-style-type: none"> See parameter 3602 START TIME 1. 	00:00:00 ... 23:59:58	2 s	12:00:00	
3607	STOP TIME 2 Defines timer 2 daily stop time. <ul style="list-style-type: none"> See parameter 3603 STOP TIME 1. 	00:00:00 ... 23:59:58	2 s	12:00:00	
3608	START DAY 2 Defines timer 2 weekly start day. <ul style="list-style-type: none"> See parameter 3604 START DAY 1. 	1...7	1	1	
3609	STOP DAY 2 Defines timer 2 weekly stop day. <ul style="list-style-type: none"> See parameter 3605 STOP DAY 1. 	1...7	1	1	
3610	START TIME 3 Defines timer 3 daily start time. <ul style="list-style-type: none"> See parameter 3602 START TIME 1. 	00:00:00 ... 23:59:58	2 s	12:00:00	
3611	STOP TIME 3 Defines timer 3 daily stop time. <ul style="list-style-type: none"> See parameter 3603 STOP TIME 1. 	00:00:00 ... 23:59:58	2 s	12:00:00	
3612	START DAY 3 Defines timer 3 weekly start day. <ul style="list-style-type: none"> See parameter 3604 START DAY 1. 	1...7	1	1	
3613	STOP DAY 3 Defines timer 3 weekly stop day. <ul style="list-style-type: none"> See parameter 3605 STOP DAY 1. 	1...7	1	1	
3614	START TIME 4 Defines timer 4 daily start time. <ul style="list-style-type: none"> See parameter 3602 START TIME 1. 	00:00:00 ... 23:59:58	2 s	12:00:00	
3615	STOP TIME 4 Defines timer 4 daily stop time. <ul style="list-style-type: none"> See parameter 3603 STOP TIME 1. 	00:00:00 ... 23:59:58	2 s	12:00:00	

Group 36: Timed functions

Code	Description	Range	Resolution	Default	S
3616	START DAY 4 Defines timer 4 weekly start day. • See parameter 3604 START DAY 1 .	1...7	1	1	
3617	STOP DAY 4 Defines timer 4 weekly stop day. • See parameter 3605 STOP DAY 1 .	1...7	1	1	
3622	BOOST SEL Selects the source for the booster signal. 0 = NOT SEL – Booster signal is disabled. 1 = DI1 – Defines DI1 as the booster signal. 2...5 = DI2...DI5 – Defines DI2...DI5 as the booster signal. -1 = DI1(INV) – Defines an inverted digital input DI1 as the booster signal. -2...-5 = DI2(INV)...DI5(INV) – Defines an inverted digital input DI2...DI5 as the booster signal.	-5...5	1	0	
3623	BOOSTER TIME Defines the booster ON time. Time is started when booster sel signal is released. If parameter range is 01:30:00, then booster is active for 1 hour and 30 minutes after activation DI is released.	00:00:00 ... 23:59:58	2 s	12:00:00	

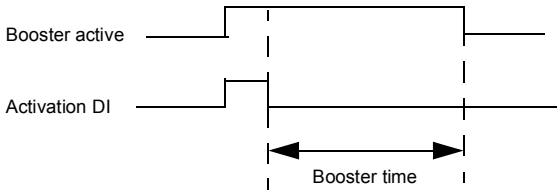

Group 36: Timed functions					
Code	Description	Range	Resolution	Default	S
3626	<p>TIMER 1 SRC</p> <p>Defines the time periods used by the timer.</p> <p>0 = NOT SEL- No timers have been selected.</p> <p>1 = P1 – Time Period 1 selected in the timer.</p> <p>2 = P2 – Time Period 2 selected in the timer.</p> <p>3 = P1+P2 – Time Periods 1 and 2 selected in the timer.</p> <p>4 = P3 – Time Period 3 selected in the timer.</p> <p>5 = P1+P3 – Time Periods 1 and 3 selected in the timer.</p> <p>6 = P2+P3 – Time Periods 2 and 3 selected in the timer.</p> <p>7 = P1+P2+P3 – Time Periods 1, 2 and 3 selected in the timer.</p> <p>8 = P4 – Time Period 4 selected in the timer.</p> <p>9 = P1+P4 – Time Periods 4 and 1 selected in the timer.</p> <p>10 = P2+P4 – Time Periods 4 and 2 selected in the timer.</p> <p>11 = P1+P2+P4 – Time Periods 4, 2 and 1 selected in the timer.</p> <p>12 = P3+P4 – Time Periods 4 and 3 selected in the timer.</p> <p>13 = P1+P3+P4 – Time Periods 4, 3 and 1 selected in the timer.</p> <p>14 = P2+P3+P4 – Time Periods 4, 3 and 2 selected in the timer.</p> <p>15 = P1+P2+P3+P4 – Time Periods 4, 3, 2 and 1 selected in the timer.</p> <p>16 = BOOST – Booster selected in the timer.</p> <p>17 = P1+B – Booster and Time Period 1 selected in the timer.</p> <p>18 = P2+B – Booster and Time Period 2 selected in the timer.</p> <p>19 = P1+P2 B – Booster and Time Periods 1 and 2 selected in the timer.</p> <p>20 = P3+B – Booster and Time Period 3 selected in the timer function.</p> <p>21 = P1+P3+B – Booster and Time Period 3 and 1 selected in the timer.</p> <p>22 = P2+P3+B – Booster and Time Periods 3 and 2 selected in the timer.</p> <p>23 = P1+P2+P3+B – Booster and Time Periods 3, 2 and 1 selected in the timer.</p> <p>24 = P4+B – Booster and Time Periods 4 selected in the timer.</p> <p>25 = P1+P4+B – Booster and Time Period 4 and Timer 1 selected in the timer.</p> <p>26 = P2+P4+B – Booster and Time Period 4 and 2 selected in the timer.</p> <p>27 = P1+P2+P4+B – Booster and Time Periods 4, 2 and 1 selected in the timer.</p> <p>28 = P3+P4+B – Booster and Time Periods 4 and 3.</p> <p>29 = P1+P3+P4+B – Booster and Time Periods 4, 3 and 1 selected in the timer.</p> <p>30 = P2+P3+P4+B – Booster and Time Periods 4, 3 and 2 selected.</p> <p>31 = P1+2+3+4+B – Booster and Time Periods 4, 3, 2 and 1 selected.</p> <p>32 = ALTERNATING – Alternating time period is enabled. All other time periods P1, P2, P1+P2 and P3 are ignored (for the specific timed function).</p> <p>48 = ALT+BOOSTER – Alternating time period and booster timer are enabled simultaneously.</p>	0...48	1	0	S
3627	<p>TIMER 2 SRC</p> <p>See parameter 3626.</p>	0...48	1	0	
3628	<p>TIMER 3 SRC</p> <p>See parameter 3626.</p>	0...48	1	0	
3629	<p>TIMER 4 SRC</p> <p>See parameter 3626.</p>	0...48	1	0	

Group 36: Timed functions					
Code	Description	Range	Resolution	Default	S
3630	ALTERNATING TIMER Defines the time interval for the timer to switch between On (1) and Off (0) states (starting from the On state), based on the selections ALTERNATING or ALT+BOOSTER in the timer source parameters 3626... 3629. <ul style="list-style-type: none"> ALTERNATING – Alternating time period is enabled. The time periods P1, P2, P1+P2 and P3 are ignore for the specific timed function. ALT+BOOSTER – Alternating time period and booster times are enabled simultaneously. 	0.0...1000.0 h	1	0.0 h	

Group 37: User load curve

This new group defines supervision of user adjustable load curves (motor torque as a function of frequency). The curve is defined by five points. - The function replaces deleted underload parameters 3013...3015

Group 37: User load curve					
Code	Description	Range	Resolution	Default	S
3701	USER LOAD C MODE Supervision mode for the user adjustable load curves. This functionality replaces the former underload supervision in <i>Group 30: Fault functions</i> . 0 = NOT SEL – Supervision is not active. 1 = UNDERLOAD – Supervision for the torque dropping below the underload curve. 2 = OVERLOAD – Supervision for the torque exceeding the overload curve. 3 = BOTH – Supervision for the torque dropping below the underload curve or exceeding the overload curve.	0...3	1	0	

Motor torque (%)

Overload area

Allowed operating area

Underload area

Output frequency (Hz)

Group 37: User load curve					
Code	Description	Range	Resolution	Default	S
3702	USER LOAD C FUNC Action wanted during load supervision. 1 = FAULT – A fault is generated when the condition defined by <i>3701 USER LOAD C MODE</i> has been valid longer than the time set by <i>3703 USER LOAD C TIME</i> . 2 = ALARM – An alarm is generated when the condition defined by <i>3701 USER LOAD C MODE</i> has been valid longer than half of the time defined by <i>3703 USER LOAD C TIME</i> .	1, 2	1	1	
3703	USER LOAD C TIME Defines the time limit for generating a fault. Half of this time is used as the limit for generating an alarm.	10 ... 400 s		20 s	
3704	LOAD FREQ 1 Defines the frequency value of the first curve definition point. Must be smaller than <i>3707 LOAD FREQ 2</i> .	0 ... 500 Hz		5 Hz	
3705	LOAD TORQ LOW 1 Defines the torque value of the first underload curve definition point. Must be smaller than <i>3706 LOAD TORQ HIGH 1</i> .	0 ... 600%		10%	
3706	LOAD TORQ HIGH 1 Defines the torque value of the first overload curve definition point.	0 ... 600%		300%	
3707	LOAD FREQ 2 Defines the frequency value of the second curve definition point. Must be smaller than <i>3710 LOAD FREQ 3</i> .	0 ... 500 Hz		25%	
3708	LOAD TORQ LOW 2 Defines the torque value of the second underload curve definition point. Must be smaller than <i>3709 LOAD TORQ HIGH 2</i> .	0 ... 600%		15%	
3709	LOAD TORQ HIGH 2 Defines the torque value of the second overload curve definition point.	0 ... 600%		300%	
3710	LOAD FREQ 3 Defines the frequency value of the third load curve definition point.	0 ... 500 Hz		43 Hz	
3711	LOAD TORQ LOW 3 Defines the torque value of the third underload curve definition point. Must be smaller than <i>3712 LOAD TORQ HIGH 3</i> .	0 ... 600%		25%	
3712	LOAD TORQ HIGH 3 Defines the torque value of the third overload curve definition point.	0 ... 600%		300%	
3713	LOAD FREQ 4 Defines the frequency value of the fourth load curve definition point.	0 ... 500 Hz		50 Hz	
3714	LOAD TORQ LOW 4 Defines the torque value of the fourth underload curve definition point. Must be smaller than <i>3715 LOAD TORQ HIGH 4</i> .	0 ... 600%		30%	
3715	LOAD TORQ HIGH 4 Defines the torque overvalue of the fourth load curve definition point.	0 ... 600%		300%	

Group 37: User load curve					
Code	Description	Range	Resolution	Default	S
3716	LOAD FREQ 5 Defines the frequency value of fifth load curve definition point.	0 ... 500 Hz		500 Hz	
3717	LOAD TORQ LOW 5 Defines the torque value of the fifth underload curve definition point. Must be smaller than 3718 LOAD TORQ HIGH 5 .	0 ... 600%		30%	
3718	LOAD TORQ HIGH 5 Defines the torque value of the fifth overload curve definition point.	0 ... 600%		300%	

■ Group 40: Process PID set 1

This group defines a set of parameters used with the Process PID (PID1) controller.

Typically only parameters in this group are needed.

PID controller – basic set-up

In PID control mode, the drive compares a reference signal (setpoint) to an actual signal (feedback), and automatically adjusts the speed of the drive to match the two signals. The difference between the two signals is the error value.

Typically PID control mode is used, when the speed of a fan or pump needs to be controlled based on pressure, flow or temperature. In most cases – when there is only 1 transducer signal wired to the drive – only parameter group 40 is needed.

A schematic of setpoint/feedback signal flow using parameter group 40 is presented below.

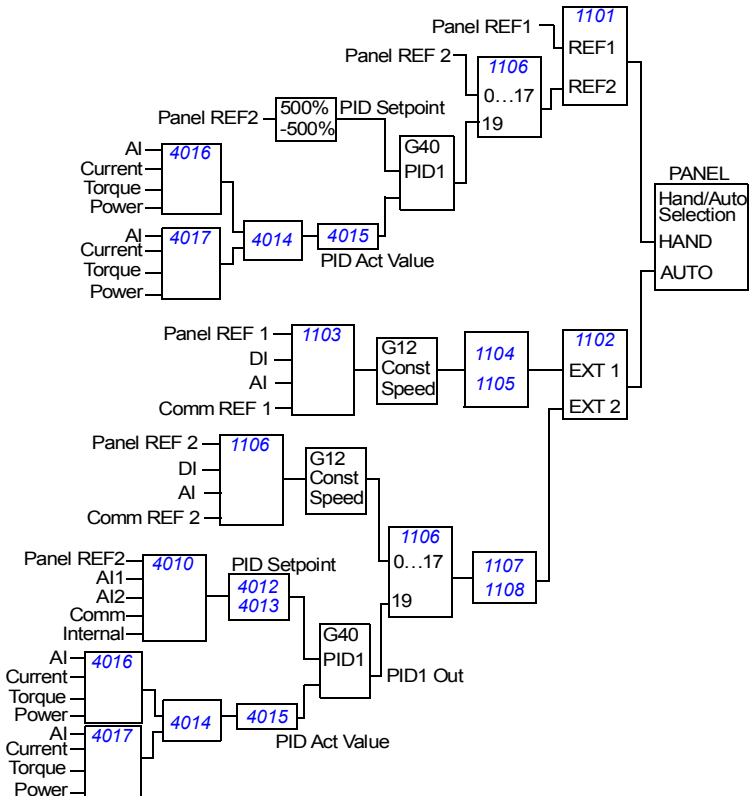

Note: To activate and use the PID controller, parameter *1106 REF2 SELECT* must be set to value 19.

PID controller – advanced

ACS320 has 2 separate PID controllers:

- Process PID (PID1)
- External PID (PID2).

Process PID (PID1) has 2 separate sets of parameters:

- Process PID (PID1) SET1, defined in *Group 40: Process PID set 1*
- Process PID (PID1) SET2, defined in *Group 41: Process PID set 2*.

You can select between the 2 different sets by using parameter *4027 PID 1 PARAM SET*.

Typically two different PID controller sets are used when the load of the motor changes considerably from one situation to another.

You can use External PID (PID2), defined in [Group 42: Ext / Trim PID](#), in 2 different ways:

- Instead of using additional PID controller hardware, you can set outputs of the ACS320 to control a field instrument like a damper or a valve. In this case, set Parameter 4230 to value 0. (0 is the default value.)
- You can use External PID (PID2) as an additional PID controller to Process PID (PID1) to trim or fine-tune the speed of the ACS320.

An example of the trimming is a return fan that follows the speed of the supply fan. As the return fan needs to run faster or slower than the supply fan in order to create under- or overpressure, correction factors to the supply fan speed are needed. Use External PID (PID2) in the return fan drive to provide these corrections.

Group 40: Process PID set 1					
Code	Description	Range	Resolution	Default	S
4001	<p>GAIN</p> <p>Defines the PID controller's gain.</p> <ul style="list-style-type: none"> At 0.1, the PID controller output changes one-tenth as much as the error value. At 100, the PID controller output changes one hundred times as much as the error value. <p>Use the proportional gain and integration time values to adjust the responsiveness of the system.</p> <ul style="list-style-type: none"> Low value for proportional gain and a high value for integral time ensures stable operation, but provides sluggish response. <p>If the proportional gain value is too large or the integral time too short, the system can become unstable.</p> <p>Procedure:</p> <ul style="list-style-type: none"> Initially, set: <ul style="list-style-type: none"> 4001 GAIN = 0.1. 4002 INTEGRATION TIME = 20 seconds. Start the system and see if it reaches the setpoint quickly while maintaining stable operation. If not, increase GAIN (4001) until the actual signal (or drive speed) oscillates constantly. It may be necessary to start and stop the drive to induce this oscillation. Reduce GAIN (4001) until the oscillation stops. Set GAIN (4001) to 0.4 to 0.6 times the above value. Decrease the INTEGRATION TIME (4002) until the feedback signal (or drive speed) oscillates constantly. It may be necessary to start and stop the drive to induce this oscillation. Increase INTEGRATION TIME (4002) until the oscillation stops. Set INTEGRATION TIME (4002) to 1.15 to 1.5 times the above value. If the feedback signal contains high frequency noise, increase the value of Parameter 1303 FILTER AI1 or 1306 FILTER AI2 until the noise is filtered from the signal. 	0.1 ... 100.0	0.1	2.5	

Group 40: Process PID set 1

Code	Description	Range	Resolution	Default	S
4002	<p>INTEGRATION TIME</p> <p>Defines the PID controller's integration time.</p> <p>Integration time is, by definition, is the time required to increase the output by the error value:</p> <ul style="list-style-type: none"> • Error value is constant and 100%. • Gain = 1. • Integration time of 1 second denotes that a 100% change is achieved in 1 second. <p>0.0 = NOT SEL Disables integration (I-part of controller).</p> <p>0.1 ... 3600.0 = Integration time (seconds).</p> <p>See parameter 4001 GAIN for adjustment procedure.</p>	0.0 ... 3600.0 s	0.1 s	3.0 s	S
4003	<p>DERIVATION TIME</p> <p>Defines the PID controller's derivation time.</p> <ul style="list-style-type: none"> • You can add the derivative of the error to the PID controller output. The derivative is the error value's rate of change. For example, if the process error value changes linearly, the derivative is a constant added to the PID controller output. • Error-derivative is filtered with a 1-pole filter. The time constant of the filter is defined by parameter 4004 PID DERIV FILTER. <p>0.0 = NOT SEL Disables the error-derivative part of the PID controller output</p> <p>0.1 ... 10.0 = Derivation time (seconds)</p>	0.0 ... 10.0 s	0.1 s	0.0 s	S
4004	<p>PID DERIV FILTER</p> <p>Defines the filter time constant for the error-derivative part of the PID controller output.</p> <ul style="list-style-type: none"> • Before being added to the PID controller output, the error-derivative is filtered with a 1-pole filter. • Increasing the filter time smooths the error-derivative, reducing noise. <p>0.0 = NOT SEL Disables the error-derivative filter.</p> <p>0.1 ... 10.0 = Filter time constant (seconds).</p>	0.0 ... 10.0 s	0.1 s	0.1 s	S

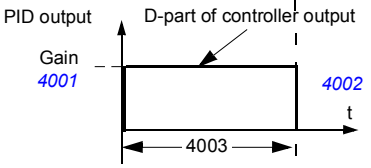
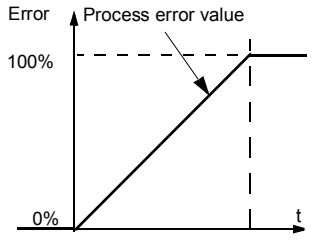
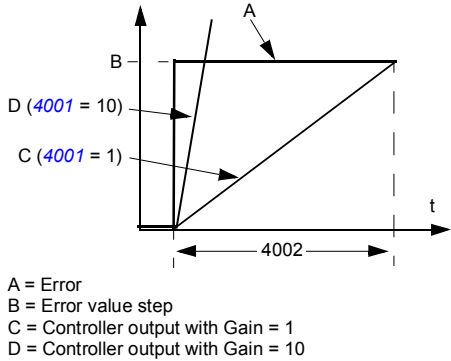

Group 40: Process PID set 1																				
Code	Description	Range	Resolution	Default	S															
4005	<p>ERROR VALUE INV</p> <p>Selects either a normal or inverted relationship between the feedback signal and the drive speed.</p> <p>0 = NO – Normal, a decrease in feedback signal increases drive speed. Error = Ref - Fbk</p> <p>1 = YES – Inverted, a decrease in feedback signal decreases drive speed. Error = Fbk - Ref</p>	0, 1	-	0																
4006	<p>UNITS</p> <p>Selects the unit for the PID controller actual values. (PID1 parameters <i>0128</i>, <i>0130</i>, and <i>0132</i>).</p> <ul style="list-style-type: none"> See parameter <i>3405 OUTPUT1 UNIT</i> for list of available units. 	0...31	-	4																
4007	<p>UNIT SCALE</p> <p>Defines the decimal point location in PID controller actual values.</p> <ul style="list-style-type: none"> Enter the decimal point location counting in from the right of the entry. See table for example using pi (3.14159). 	0...4	1	1																
					<table border="1"> <thead> <tr> <th>4007 value</th> <th>Entry</th> <th>Display</th> </tr> </thead> <tbody> <tr> <td>0</td> <td>0003</td> <td>3</td> </tr> <tr> <td>1</td> <td>0031</td> <td>3.1</td> </tr> <tr> <td>2</td> <td>0314</td> <td>3.14</td> </tr> <tr> <td>3</td> <td>3142</td> <td>3.142</td> </tr> </tbody> </table>	4007 value	Entry	Display	0	0003	3	1	0031	3.1	2	0314	3.14	3	3142	3.142
4007 value	Entry	Display																		
0	0003	3																		
1	0031	3.1																		
2	0314	3.14																		
3	3142	3.142																		
4008	<p>0 % VALUE</p> <p>Defines (together with the next parameter) the scaling applied to the PID controller's actual values (PID1 parameters <i>0128</i>, <i>0130</i>, and <i>0132</i>).</p> <ul style="list-style-type: none"> Units and scale are defined by parameters <i>4006 UNITS</i> and <i>4007 UNIT SCALE</i>. 	-3276.8 ... 3276.7	-	-																
4009	<p>100 % VALUE</p> <p>Defines (together with the previous parameter) the scaling applied to the PID controller's actual values.</p> <ul style="list-style-type: none"> Units and scale are defined by parameters <i>4006 UNITS</i> and <i>4007 UNIT SCALE</i>. 	-3267.8 ... 3276.7	-	-																

Group 40: Process PID set 1

Code	Description	Range	Resolution	Default	S
4010	SET POINT SEL	0...32	1	0	✓
	<p>Defines the reference signal source for the PID controller.</p> <ul style="list-style-type: none"> Parameter has no significance when the PID regulator is by-passed (see parameter 8121 REG BYPASS CTRL). <p>0 = KEYPAD – Control panel provides reference. 1 = AI1 – Analog input 1 provides reference. 2 = AI2 – Analog input 2 provides reference. 8 = COMM – Fieldbus provides reference. 9 = COMM+AI1 – Defines a fieldbus and analog input 1 (AI1) combination as the reference source. See Analog Input Reference Correction below. 10 = COMM*AI1 – Defines a fieldbus and analog input 1 (AI1) combination as the reference source. See Analog Input Reference Correction below. 11 = DI3U, 4D(RNC) – Digital inputs, acting as a motor potentiometer control, provide reference. <ul style="list-style-type: none"> DI3 increases the speed (the U stands for “up”) DI4 decreases the reference (the D stands for “down”). Parameter 2205 ACCELER TIME 2 controls the reference signal’s rate of change. R = Stop command resets the reference to zero. NC = Reference value is not copied. 12 = DI3U, 4D(NC) – Same as DI3U, 4D(RNC) above, except: <ul style="list-style-type: none"> Stop command does not reset reference to zero. At restart the motor ramps up, at the selected acceleration rate, to the stored reference. 14 = AI1+AI2 – Defines an analog input 1 (AI1) and analog input 2 (AI2) combination as the reference source. See Analog Input Reference Correction below. 15 = AI1*AI2 – Defines an analog input 1 (AI1) and analog input 2 (AI2) combination as the reference source. See Analog Input Reference Correction below. 16 = AI1-AI2 – Defines an analog input 1 (AI1) and analog input 2 (AI2) combination as the reference source. See Analog Input Reference Correction below. 17 = AI1/AI2 – Defines an analog input 1 (AI1) and analog input 2 (AI2) combination as the reference source. See Analog Input Reference Correction below. 19 = INTERNAL – A constant value set using parameter 4011 provides reference.</p>				

Group 40: Process PID set 1															
Code	Description	Range	Resolution	Default	S										
	Analog input reference correction Parameter values 9, 10, and 14...17 use the formula in the following table.														
	<table border="1"> <thead> <tr> <th>Value Setting</th> <th>AI reference is calculated as following:</th> </tr> </thead> <tbody> <tr> <td>C + B</td> <td>C value + (B value - 50% of reference value)</td> </tr> <tr> <td>C * B</td> <td>C value * (B value / 50% of reference value)</td> </tr> <tr> <td>C - B</td> <td>(C value + 50% of reference value) - B value</td> </tr> <tr> <td>C / B</td> <td>(C value * 50% of reference value) / B value</td> </tr> </tbody> </table>					Value Setting	AI reference is calculated as following:	C + B	C value + (B value - 50% of reference value)	C * B	C value * (B value / 50% of reference value)	C - B	(C value + 50% of reference value) - B value	C / B	(C value * 50% of reference value) / B value
Value Setting	AI reference is calculated as following:														
C + B	C value + (B value - 50% of reference value)														
C * B	C value * (B value / 50% of reference value)														
C - B	(C value + 50% of reference value) - B value														
C / B	(C value * 50% of reference value) / B value														
	Where: <ul style="list-style-type: none"> • C = Main Reference value (= COMM for values 9, 10 and = AI1 for values 14...17). • B = Correcting reference (= AI1 for values 9, 10 and = AI2 for values 14...17). 														
	Example: The figure shows the reference source curves for value settings 9, 10, and 14...17, where: <ul style="list-style-type: none"> • C = 25%. • Parameter 4012 SETPOINT MIN = 0. • Parameter 4013 SETPOINT MAX = 0. • B varies along the horizontal axis. 														
	31 = DI4U, 5D(NC) – See selection DI3U,4D(NC). 32 = FREQ INPUT – Frequency limit.														
4011	INTERNAL SETPNT	-3276.8 ... 3277.7%	0.1%	40.0%											
	Selects a constant value as a process PID controller reference, when parameter 4010 SET POINT SEL value is set to INTERNAL. <ul style="list-style-type: none"> • Unit and range depend on the unit and scale defined by parameters 4006 UNITS and 4007 UNIT SCALE. 														

Group 40: Process PID set 1

Code	Description	Range	Resolution	Default	S
4012	<p>SETPOINT MIN</p> <p>Defines the minimum value for the selected PID reference signal source. See parameter <i>4010 SET POINT SEL</i>. Value in percent.</p> <p>Example: Analog input AI1 is selected as the PID reference source (value of parameter <i>4010</i> is AI1). The reference minimum and maximum correspond to the <i>1301 MINIMUM AI1</i> and <i>1302 MAXIMUM AI1</i> settings as follows.</p>	-500.0 ... 500.0%	0.1%	0.0%	
4013	<p>SETPOINT MAX</p> <p>Defines the maximum value for the selected PID reference signal source. See parameters <i>4010 SET POINT SEL</i> and <i>4012 SETPOINT MIN</i>. Value in percent.</p>	-500.0 ... 500.0%	0.1%	100.0%	
4014	<p>FBK SEL</p> <p>Defines the PID controller feedback (actual signal).</p> <ul style="list-style-type: none"> You can define a combination of two actual values (ACT1 and ACT2) as the feedback signal. Use parameter <i>4016 ACT1 INPUT</i> to define the source for actual value 1 (ACT1). Use parameter <i>4017 ACT2 INPUT</i> to define the source for actual value 2 (ACT2). <p>1 = ACT1 – Actual value 1 (ACT1) provides the feedback signal. 2 = ACT1-ACT2 – ACT1 minus ACT2 provides the feedback signal. 3 = ACT1+ACT2 – ACT1 plus ACT2 provides the feedback signal. 4 = ACT1*ACT – ACT1 times ACT2 provides the feedback signal. 5 = ACT1/ACT2 – ACT1 divided by ACT2 provides the feedback signal. 6 = MIN (ACT1, 2) – The smaller of ACT1 or ACT2 provides the feedback signal. 7 = MAX (ACT1, 2) – The greater of ACT1 or ACT2 provides the feedback signal. 8 = sqrt(ACT1-2) – Square root of the value for ACT1 minus ACT2 provides the feedback signal. 9 = sqA1 + sqA2 – Square root of ACT1 plus the square root of ACT2 provides the feedback signal. 10 = sqrt(ACT1) – Square root of ACT1 provides the feedback signal. 11 = COMM FBK 1 – Signal <i>0158 PID COMM VALUE 1</i> provides the feedback signal. 12 = COMM FBK 2 – Signal <i>0159 PID COMM VALUE 2</i> provides the feedback signal. 13 = AVE(ACT1,2) – The average of ACT1 and ACT2 provides the feedback signal.</p>	1...13	1	1	

Group 40: Process PID set 1					
Code	Description	Range	Resolution	Default	S
4015	<p>FBK MULTIPLIER</p> <p>Defines an extra multiplier for the PID FBK value defined by parameter 4014 FBK SEL.</p> <ul style="list-style-type: none"> Used mainly in applications where the flow is calculated from the pressure difference. <p>0 = NOT SELECTED. -32.768...32.767 = Multiplier applied to the signal defined by parameter 4014 FBK SEL.</p> <p>Example: $FBK = Multiplier \times \sqrt{A1 - A2}$</p>	-32.768...32.767	0.001	0	
4016	<p>ACT1 INPUT</p> <p>Defines the source for actual value 1 (ACT1).</p> <p>1 = AI 1 – Uses analog input 1 for ACT1. 2 = AI 2 – Uses analog input 2 for ACT1. 3 = CURRENT – Uses current for ACT1, scaled so:</p> <ul style="list-style-type: none"> Min ACT1 = 0 current Max ACT1 = 2 x nominal current <p>4 = TORQUE – Uses torque for ACT1, scaled so:</p> <ul style="list-style-type: none"> Min ACT1 = -2 x nominal torque Max ACT1 = 2 x nominal torque <p>5 = POWER – Uses power for ACT1, scaled so:</p> <ul style="list-style-type: none"> Min ACT1 = -2 x nominal power Max ACT1 = 2 x nominal power <p>6 = COMM ACT 1 – Uses value of signal 0158 PID COMM VALUE 1 for ACT1. 7 = COMM ACT 2 – Uses value of signal 0159 PID COMM VALUE 2 for ACT1. 8 = FREQ INPUT</p>	1...8	1	2	✓
4017	<p>ACT2 INPUT</p> <p>Defines the source for actual value 2 (ACT2).</p> <p>1 = AI 1 – Uses analog input 1 for ACT2. 2 = AI 2 – Uses analog input 2 for ACT2. 3 = CURRENT – Uses current for ACT2, scaled so:</p> <ul style="list-style-type: none"> Min ACT2 = 0 current Max ACT2 = 2 x nominal current <p>4 = TORQUE – Uses torque for ACT2, scaled so:</p> <ul style="list-style-type: none"> Min ACT2 = -2 x nominal torque Max ACT2 = 2 x nominal torque <p>5 = POWER – Uses power for ACT2, scaled so:</p> <ul style="list-style-type: none"> Min ACT2 = -2 x nominal power Max ACT2 = 2 x nominal power <p>6 = COMM ACT 1 – Uses value of signal 0158 PID COMM VALUE 1 for ACT2. 7 = COMM ACT 2 – Uses value of signal 0159 PID COMM VALUE 2 for ACT2. 8 = FREQ INPUT – Frequency input.</p>	1...8	1	2	✓

Group 40: Process PID set 1

Code	Description	Range	Resolution	Default	S																								
4018	<p>ACT1 MINIMUM</p> <ul style="list-style-type: none"> • Sets the minimum value for ACT1. • Scales the source signal used as the actual value ACT1 (defined by parameter 4016 ACT1 INPUT ACT1 INPUT). For parameter 4016 values 6 (COMM ACT 1) and 7 (COMM ACT 2) scaling is not done. 	-1000 ... 1000%	1%	0%																									
	<table border="1"> <thead> <tr> <th>Par. 4016</th> <th>Source</th> <th>Source min.</th> <th>Source max.</th> </tr> </thead> <tbody> <tr> <td>1</td> <td>Analog input 1</td> <td>1301 MINIMUM AI1</td> <td>1302 MAXIMUM AI1</td> </tr> <tr> <td>2</td> <td>Analog input 2</td> <td>1304 MINIMUM AI2</td> <td>1305 MAXIMUM AI2</td> </tr> <tr> <td>3</td> <td>Current</td> <td>0</td> <td>2 · nominal current</td> </tr> <tr> <td>4</td> <td>Torque</td> <td>-2 · nominal torque</td> <td>2 · nominal torque</td> </tr> <tr> <td>5</td> <td>Power</td> <td>-2 · nominal power</td> <td>2 · nominal power</td> </tr> </tbody> </table>	Par. 4016	Source	Source min.	Source max.	1	Analog input 1	1301 MINIMUM AI1	1302 MAXIMUM AI1	2	Analog input 2	1304 MINIMUM AI2	1305 MAXIMUM AI2	3	Current	0	2 · nominal current	4	Torque	-2 · nominal torque	2 · nominal torque	5	Power	-2 · nominal power	2 · nominal power				
Par. 4016	Source	Source min.	Source max.																										
1	Analog input 1	1301 MINIMUM AI1	1302 MAXIMUM AI1																										
2	Analog input 2	1304 MINIMUM AI2	1305 MAXIMUM AI2																										
3	Current	0	2 · nominal current																										
4	Torque	-2 · nominal torque	2 · nominal torque																										
5	Power	-2 · nominal power	2 · nominal power																										
	<ul style="list-style-type: none"> • See the figure below: A= Normal; B = Inversion (ACT1 MINIMUM > ACT1 MAXIMUM) <div style="display: flex; justify-content: space-around;"> <div style="text-align: center;"> <p>ACT1 (%)</p> <p>4019</p> <p>4018</p> <p>1301 Source min.</p> <p>1302 Source max.</p> <p>Source signal</p> <p>A</p> </div> <div style="text-align: center;"> <p>ACT1 (%)</p> <p>4018</p> <p>4019</p> <p>1301 Source min.</p> <p>1302 Source max.</p> <p>Source signal</p> <p>B</p> </div> </div>																												
4019	<p>ACT1 MAXIMUM</p> <p>Sets the maximum value for ACT1.</p> <ul style="list-style-type: none"> • See 4018 ACT1 MINIMUM. 	-1000 ... 1000%	1%	100%																									
4020	<p>ACT2 MINIMUM</p> <p>Sets the minimum value for ACT2.</p> <ul style="list-style-type: none"> • See 4018 ACT1 MINIMUM. 	-1000 ... 1000%	1%	0%																									
4021	<p>ACT2 MAXIMUM</p> <p>Sets the maximum value for ACT2.</p> <ul style="list-style-type: none"> • See 4018 ACT1 MINIMUM. 	-1000 ... 1000%	1%	100%																									

Group 40: Process PID set 1					
Code	Description	Range	Resolution	Default	S
4022	<p>SLEEP SELECTION</p> <p>Defines the control for the PID sleep function.</p> <p>0 = NOT SEL – Disables the PID sleep control function.</p> <p>1 = DI1 – Defines digital input 1 as the control for the PID sleep function.</p> <ul style="list-style-type: none"> Activating the digital input activates the sleep function. De-activating the digital input restores PID control. <p>2...5 = DI2...DI5 – Defines digital input DI2...DI5 as the control for the PID sleep function.</p> <ul style="list-style-type: none"> See DI1 above. <p>9...11 = SUPRV1 UNDER...SUPRV3 UNDER – The function is activated when parameter 3201 SUPERV 1 PARAM stays over the high limit defined by parameter 3203 SUPERV 1 LIM HI. The internal sleep criteria set by parameters 4023 PID SLEEP LEVEL and 4025 WAKE-UP DEV are not effective. The sleep start and stop delay parameters 4024 PID SLEEP DELAY and 4026 WAKE-UP DELAY are effective.</p> <p>7 = INTERNAL – Defines the output rpm/frequency, process reference, and process actual value as the control for the PID sleep function. Refer to parameters 4025 WAKE-UP DEV and 4023 PID SLEEP LEVEL.</p> <p>-1 = DI1(INV) – Defines an inverted digital input DI1 as the control for the PID sleep function.</p> <ul style="list-style-type: none"> De-activating the digital input activates the sleep function. Activating the digital input restores PID control. <p>-2...-5 = DI2(INV)...DI5(INV) – Defines an inverted digital input DI2...DI5 as the control for the PID sleep function.</p> <ul style="list-style-type: none"> See DI1(INV) above. <p>-9...-11 = SUPRV1 UNDER...SUPRV3 UNDER – The function is activated when parameter 3201 SUPERV 1 PARAM stays below the low limit defined by parameter 3202 SUPERV 1 LIM LO. The internal sleep criteria set by parameters 4023 PID SLEEP LEVEL and 4025 WAKE-UP DEV are not effective. The sleep start and stop delay parameters 4024 PID SLEEP DELAY and 4026 WAKE-UP DELAY are effective.</p>	-11...11	-	0	

Group 40: Process PID set 1

Code	Description	Range	Resolution	Default	S
4023	<p>PID SLEEP LEVEL</p> <p>Sets the motor speed / frequency that enables the PID sleep function – a motor speed / frequency below this level, for at least the time period 4024 PID SLEEP DELAY enables the PID sleep function (stopping the drive).</p> <ul style="list-style-type: none"> • Requires 4022 = 7 INTERNAL. • See figure: A = PID output level; B = PID process feedback. 	0.0 ... 120.0 Hz	0.1 Hz	0.0 Hz	
4024	<p>PID SLEEP DELAY</p> <p>Defines the delay for the sleep start function. See parameter 4023 PID SLEEP LEVEL. When the motor speed falls below the sleep level, the counter starts. When the motor speed exceeds the sleep level, the counter is reset.</p> <ul style="list-style-type: none"> • See 4023 PID SLEEP LEVEL above. 	0.0 ... 3600.0 s	0.1 s	60.0 s	

Group 40: Process PID set 1					
Code	Description	Range	Resolution	Default	S
4025	<p>WAKE-UP DEV</p> <p>Defines the wake-up deviation – a deviation from the setpoint greater than this value, for at least the time period 4026 WAKE-UP DELAY, re-starts the PID controller.</p> <ul style="list-style-type: none"> Parameters 4006 UNITS and 4007 UNIT SCALE define the units and scale. Parameter 4005 ERROR VALUE INV = 0, Wake-up level = Setpoint – Wake-up deviation. Parameter 4005 ERROR VALUE INV = 1, Wake-up level = Setpoint + Wake-up deviation. Wake-up level can be above or below setpoint. <p>See the figure:</p> <ul style="list-style-type: none"> C = Wake-up level when parameter 4005 ERROR VALUE INV = 1 D = Wake-up level when parameter 4005 ERROR VALUE INV = 0 E = Feedback is above wake-up level and lasts longer than 4026 WAKE-UP DELAY – PID function wakes up. F = Feedback is below wake-up level and lasts longer than 4026 WAKE-UP DELAY – PID function wakes up. 	0.0 ... 3276.7	0.1	0.0	
4026	<p>WAKE-UP DELAY</p> <p>Defines the wake-up delay – a deviation from the setpoint greater than 4025 WAKE-UP DEV, for at least this time period re-starts the PID controller.</p> <ul style="list-style-type: none"> See 4023 PID SLEEP LEVEL above. 	0.00 ... 60.00 s	0.01 s	0.50 s	

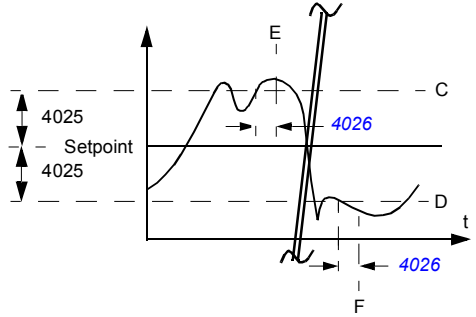

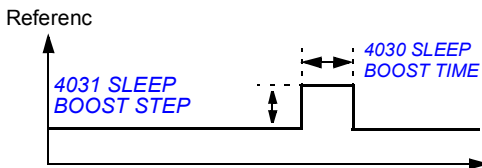
Group 40: Process PID set 1					
Code	Description	Range	Resolution	Default	S
4027	<p>PID 1 PARAM SET</p> <p>Defines how selections are made between PID set 1 and PID set 2. PID parameter set selection. When set 1 is selected, parameters 4001...4026 are used.</p> <p>When set 2 is selected, parameters 4001...4026 are used.</p> <p>0 = SET 1 – PID set 1 (parameters 4001...4026) is active.</p> <p>1 = DI1 – Defines digital input 1 as the control for PID set selection.</p> <ul style="list-style-type: none"> Activating the digital input selects PID set 2. De-activating the digital input selects PID set 1. <p>2...5 = DI2...DI5 – Defines digital input DI2...DI5 as the control for PID set selection.</p> <ul style="list-style-type: none"> See DI1 above. <p>7 = SET 2 – PID set 2 (parameters 4101...4126) is active.</p> <p>8...11 = TIMER 1...4 – Defines the Timer as the control for the PID set selection (Timer de-activated = PID set 1; Timer activated = PID set 2)</p> <p>See parameter Group 36: Timed functions.</p> <p>-1 = DI1(INV) – Defines an inverted digital input 1 as the control for PID set selection.</p> <ul style="list-style-type: none"> Activating the digital input selects PID set 1. De-activating the digital input selects PID set 2. <p>-2...-5 = DI2(INV)...DI5(INV) – Defines an inverted digital input DI2...DI5 as the control for PID set selection.</p> <ul style="list-style-type: none"> See DI1(INV) above. 	-5...11	1	0	
4028	<p>PID OUT MIN</p> <p>Defines the minimum value of PID output.</p>	-1000.0 ... 1000.0%	1 = 0.1%	-100.0%	
4029	<p>PID OUT MAX</p> <p>Defines the maximum value of PID output.</p>	-1000.0 ... 1000.0%	1 = 0.1%	-100.0%	
4030	<p>SLEEP BOOST TIME</p> <p>Defines the boost time for the sleep boost step. See parameter 4031 SLEEP BOOST STEP.</p> 	0.0 ... 3600.0 s	1 = 0.1 s	0.0 s	
4031	<p>SLEEP BOOST STEP</p> <p>When the drive is entering sleep mode, the reference (PID setpoint) is increased by this percentage for the time defined by parameter 4030 SLEEP BOOST TIME.</p>	0.0 ... 100.0%	1 = 0.1%	0.0%	
4032	<p>PID REF ACC TIME</p> <p>Defines the time for the reference (PID setpoint) increase from 0 to 100%.</p> <p>Note: Parameters 4032...4036 are active even if the process PID set 2 (Group 41: Process PID set 2) is used. Acceleration time</p>	0.0 ... 1800.0 s	1 = 0.1 s	0.0 s	

Group 40: Process PID set 1					
Code	Description	Range	Resolution	Default	S
4033	PID REF DEC TIME Defines the time for the reference (PID setpoint) decrease from 100 to 0%.	0.0 ... 1800.0 s	1 = 0.1 s	0.0 s	
4034	PID REF FREEZE Freezes the input (reference, PID setpoint) of the process PID controller. 0 = NOT SEL – Not selected 1 = DI1 – Reference is frozen on the rising edge of digital input DI1. 2 = DI2 – See selection DI1. 3 = DI3 – See selection DI1. 4 = DI4 – See selection DI1. 5 = DI5 – See selection DI1. -1 = DI1(INV) – Reference is frozen on the falling edge of digital input DI1. -2 = DI2(INV) – See selection DI1(INV). -3 = DI3(INV) – See selection DI1(INV). -4 = DI4(INV) – See selection DI1(INV). -5 = DI5(INV) – See selection DI1(INV).				NOT SEL
4035	PID OUT FREEZE Freezes the output of the process PID controller. 0 = NOT SEL – Not selected 1 = DI1 – Output is frozen on the rising edge of digital input DI1 2 = DI2 – See selection DI1. 3 = DI3 – See selection DI1. 4 = DI4 – See selection DI1. 5 = DI5 – See selection DI1. -1 = DI1(INV) – Output is frozen on the falling edge of digital input DI1. -2 = DI2(INV) – See selection DI1(INV). -3 = DI3(INV) – See selection DI1(INV). -4 = DI4(INV) – See selection DI1(INV). -5 = DI5(INV) – See selection DI1(INV).				NOT SEL
4036	INTERNAL SETPNT2 Selects a constant value as the process PID controller reference, which becomes active when parameter <i>4010 SET POINT SEL</i> value is set to INTERNAL and setpoint 2 is selected with the input defined by parameter <i>4039 INT SETPNT SEL</i> . Value in percent.	-3276.8 ... 3276.7	-	-	
4037	INTERNAL SETPNT3 Selects a constant value as the process PID controller reference, which becomes active when parameter <i>4010 SET POINT SEL</i> value is set to INTERNAL and setpoint 3 is selected with the input defined by parameter <i>4039 INT SETPNT SEL</i> . Value in percent.	-3276.8 ... 3276.7	-	-	
4038	INTERNAL SETPNT4 Selects a constant value as the process PID controller reference, which becomes active when parameter <i>4010 SET POINT SEL</i> value is set to INTERNAL and setpoint 4 is selected with the input defined by parameter <i>4039 INT SETPNT SEL</i> . Value in percent.	-3276.8 ... 3276.7	-	-	

Group 40: Process PID set 1

Code	Description	Range	Resolution	Default	S															
4039	INT SETPNT SEL			NOT SEL																
	<p>Selects the source for the selection of the internal setpoint used as the process PID controller reference when parameter <i>4010 SET POINT SEL</i> value is set to INTERNAL.</p> <p>Example:</p> <p><i>4010 SET POINT SEL</i> = INTERNAL <i>4039 INT SETPNT SEL</i> = DI2 Digital input DI2 = 1 -> <i>4012 SETPOINT MIN</i> is used as the reference.</p> <p>0 = NOT SEL – <i>4011 INTERNAL SETPNT</i> is used as the reference. 1 = DI1 0 = <i>4011 INTERNAL SETPNT</i> is used. 1 = <i>4036 INTERNAL SETPNT2</i> is used.</p> <p>2 = DI2 – See selection DI1. 3 = DI3 – See selection DI1. 4 = DI4 – See selection DI1. 5 = DI5 – See selection DI1. 7 = DI1,2 – Selects with digital inputs DI1 and DI2 which internal setpoint is used as the reference. 1 = DI active, 0 = DI inactive.</p>																			
	<table border="1"> <thead> <tr> <th>DI1</th> <th>DI2</th> <th>Internal setpoint selected</th> </tr> </thead> <tbody> <tr> <td>0</td> <td>0</td> <td><i>4011 INTERNAL SETPNT</i></td> </tr> <tr> <td>1</td> <td>0</td> <td><i>4036 INTERNAL SETPNT2</i></td> </tr> <tr> <td>0</td> <td>1</td> <td><i>4037 INTERNAL SETPNT3</i></td> </tr> <tr> <td>1</td> <td>1</td> <td><i>4038 INTERNAL SETPNT4</i></td> </tr> </tbody> </table>					DI1	DI2	Internal setpoint selected	0	0	<i>4011 INTERNAL SETPNT</i>	1	0	<i>4036 INTERNAL SETPNT2</i>	0	1	<i>4037 INTERNAL SETPNT3</i>	1	1	<i>4038 INTERNAL SETPNT4</i>
DI1	DI2	Internal setpoint selected																		
0	0	<i>4011 INTERNAL SETPNT</i>																		
1	0	<i>4036 INTERNAL SETPNT2</i>																		
0	1	<i>4037 INTERNAL SETPNT3</i>																		
1	1	<i>4038 INTERNAL SETPNT4</i>																		
	<p>8 = DI2,3 – See selection DI1,2. 9 = DI3,4 – See selection DI1,2. 10 = DI4,5 – See selection DI1,2. 15 = TIMED FUNC 1 0 = <i>4011 INTERNAL SETPNT</i> is used. 1 = <i>4036 INTERNAL SETPNT2</i> is used.</p> <p>16 = TIMED FUNC 2 – See selection TIMED FUNC 1. 17 = TIMED FUNC 3 – See selection TIMED FUNC 1. 18 = TIMED FUNC 4 – See selection TIMED FUNC 1. 19 = TIMED FUN1&2 – Selects with TIMED FUNC 1 and TIMED FUNC 2 which internal setpoint is used as the reference. 1 = timed function active, 0 = timed function inactive.</p>																			
	<table border="1"> <thead> <tr> <th>TIMED FUNC 1</th> <th>TIMED FUNC 2</th> <th>Internal setpoint selected</th> </tr> </thead> <tbody> <tr> <td>0</td> <td>0</td> <td><i>4011 INTERNAL SETPNT</i></td> </tr> <tr> <td>1</td> <td>0</td> <td><i>4036 INTERNAL SETPNT2</i></td> </tr> <tr> <td>0</td> <td>1</td> <td><i>4037 INTERNAL SETPNT3</i></td> </tr> <tr> <td>1</td> <td>1</td> <td><i>4038 INTERNAL SETPNT4</i></td> </tr> </tbody> </table>					TIMED FUNC 1	TIMED FUNC 2	Internal setpoint selected	0	0	<i>4011 INTERNAL SETPNT</i>	1	0	<i>4036 INTERNAL SETPNT2</i>	0	1	<i>4037 INTERNAL SETPNT3</i>	1	1	<i>4038 INTERNAL SETPNT4</i>
TIMED FUNC 1	TIMED FUNC 2	Internal setpoint selected																		
0	0	<i>4011 INTERNAL SETPNT</i>																		
1	0	<i>4036 INTERNAL SETPNT2</i>																		
0	1	<i>4037 INTERNAL SETPNT3</i>																		
1	1	<i>4038 INTERNAL SETPNT4</i>																		

■ Group 41: Process PID set 2

This group defines second set of parameters used with the Process PID (PID1) controller.

The operation of parameters [4101 ... 4139](#) is analogous with Process PID set 1 (PID1) parameters [4001...4039](#).

PID parameter set 2 can be selected by parameter [4027 PID 1 PARAM SET](#).

Group 41: Process PID set 2					
Code	Description	Range	Resolution	Default	S
4101 ... 4139	See parameters 4001...4039 .				

■ Group 42: Ext / Trim PID

This group defines the parameters used for the second PID controller (PID2) of ACS320.

The operation of parameters [4201 ... 4221](#) is analogous with Process PID set 1 (PID1) parameters [4001...4039](#).

Group 42: Ext / Trim PID					
Code	Description	Range	Resolution	Default	S
4201 ... 4221	See parameters 4001...4021 .				

Group 42: Ext / Trim PID					
Code	Description	Range	Resolution	Default	S
4228	<p>ACTIVATE</p> <p>Defines the source for enabling the external PID function.</p> <ul style="list-style-type: none"> Requires parameter 4230 TRIM MODE = 0 NOT SEL. <p>0 = NOT SEL – Disables external PID control.</p> <p>1 = DI1 – Defines digital input 1 as the control for enabling external PID control.</p> <ul style="list-style-type: none"> Activating the digital input enables external PID control. De-activating the digital input disables external PID control. <p>2...5 = DI2...DI5 – Defines digital input DI2...DI5 as the control for enabling external PID control.</p> <ul style="list-style-type: none"> See DI1 above. <p>7 = DRIVE RUN – Defines the start command as the control for enabling external PID control.</p> <ul style="list-style-type: none"> Activating the start command (drive is running) enables external PID control. <p>8 = ON – Defines the power-on as the control for enabling external PID control.</p> <ul style="list-style-type: none"> Activating power to the drive enables external PID control. <p>9...12 = TIMER 1...4 – Defines the Timer as the control for enabling external PID control (Timer active enables external PID control).</p> <ul style="list-style-type: none"> See parameter Group 36: Timed functions. <p>-1 = DI1(INV) – Defines an inverted digital input DI1 as the control for enabling external PID control.</p> <ul style="list-style-type: none"> Activating the digital input disables external PID control. De-activating the digital input enables external PID control. <p>-2...-5 = DI2(INV)...DI5(INV) – Defines an inverted digital input DI2...DI5 as the control for enabling external PID control.</p> <ul style="list-style-type: none"> See DI1(INV) above. 	-5...12	-	1	
4229	<p>OFFSET</p> <p>Defines the offset for the PID output.</p> <ul style="list-style-type: none"> When PID is activated, output starts from this value. When PID is deactivated, output resets to this value. Parameter is not active when parameter 4230 TRIM MODE not = 0 (trim mode is not active). 	0.0 ... 100.0%	0.1%	0.0%	
4230	<p>TRIM MODE</p> <p>Selects the type of trim, if any. Using the trim it is possible to combine a corrective factor to the drive reference.</p> <p>0 = NOT SEL – Disables the trim function.</p> <p>1 = PROPORTIONAL – Adds a trim factor that is proportional to the rpm/Hz reference.</p> <p>2 = DIRECT – Adds a trim factor based on the control loop's maximum limit.</p>	0...2	1	0	
4231	<p>TRIM SCALE</p> <p>Defines the multiplier (as a percent, plus or minus) used in the trim mode.</p>	-100.0 ... 100.0%	0.1%	0.0%	

Group 42: Ext / Trim PID					
Code	Description	Range	Resolution	Default	S
4232	<p>CORRECTION SRC</p> <p>Defines the trimming reference for the correction source.</p> <p>1 = PID2 REF – Uses appropriate REF MAX (SWITCH A OR B)</p> <ul style="list-style-type: none"> • 1105 REF1 MAX when REF1 is active (A). • 1108 REF2 MAX when REF2 is active (B). <p>2 = PID2 OUTPUT – Uses the absolute maximum speed or frequency (Switch C).</p>	1...2	1	1	
	<pre> graph LR Switch[Switch] --> Select4230[Select par. 4230] PID2ref[PID2 ref] --> PID2[PID 2] PID2 --> Select4232[Select par. 4232] Select4230 -- off --> TrimScale[Trim Scale] Select4230 -- prop or. --> Mul1[Mul.] Select4230 -- direct --> Mul2[Mul.] TrimScale --> Mul1 PID2ref --> Mul1 PID2ref --> Mul2 PID2 --> Mul2 Mul1 --> Add[Add] Mul2 --> Add Select4232 --> Add Add --> TrimmedRef[Trimmed Ref] </pre>				

■ Group 44: Pump protection

This group defines the parameters used for the set-up of pump protection.

Group 44: Pump protection					
Code	Description	Range	Resolution	Default	S
4401	<p>INLET PROT CTRL</p> <p>Enables, and selects the mode of, the primary supervision of pump/fan inlet pressure.</p> <p>Note: Inlet protection is active only when the active reference is PID.</p> <p>0 = NOT SEL – Primary inlet pressure supervision not used.</p> <p>1 = ALARM – Detection of low inlet pressure generates an alarm on the control panel display.</p> <p>2 = PROTECT – Detection of low inlet pressure generates an alarm on the control panel display. The output of the PI controller is ramped down (according to parameter 4417 PID OUT DEC TIME) to the forced reference (set by parameter 4008 INLET FORCED REF). The drive will revert to the original reference if the pressure subsequently exceeds the supervision level.</p> <p>The diagram describes the inlet pressure supervision function.</p> <p>3 = FAULT – Detection of low inlet pressure trips the drive on a fault.</p>				NOT SEL
4402	<p>AI MEASURE INLET</p> <p>Selects the analog input for pump/fan inlet pressure supervision.</p> <p>0 = NOT SEL – No analog input selected.</p> <p>1 = AI1 – Pump/fan inlet pressure monitored through analog input AI1.</p> <p>2 = AI2 – See selection AI1.</p>				NOT SEL
4403	<p>AI IN LOW LEVEL</p> <p>Sets the supervision limit for the primary inlet pressure measurement. If the value of the selected input falls below this limit, the action defined by parameter 4401 INLET PROT CTRL is taken after the delay set by parameter 4407 INLET CTRL DLY expires. The range corresponds to 0...10 V or 0...20 mA on the analog input. With a bipolar input, the absolute input value is considered.</p>	0.00 ... 100.00%	1 = 0.01%	0.00%	
4404	<p>VERY LOW CTRL</p> <p>Enables, and selects the mode of, the secondary inlet pressure supervision function. The function uses the analog input selected by parameter 4402 AI MEASURE INLET.</p> <p>0 = NOT SEL – Secondary inlet pressure supervision not used.</p> <p>1 = STOP – Detection of very low inlet pressure stops the drive. The drive will start again if the pressure exceeds the supervision level.</p> <p>2 = FAULT – Detection of very low inlet pressure trips the drive on a fault.</p>				NOT SEL

Group 44: Pump protection					
Code	Description	Range	Resolution	Default	S
4405	AI IN VERY LOW	0.00 ... 100.00%	1 = 0.01%	0.00%	
	Supervision level for the secondary inlet pressure monitoring function. See parameter 4401 INLET PROT CTRL . Supervision level.				
4406	DI STATUS INLET			NOT SEL	
	<p>Selects the digital input for connection of a pressure switch at the pump/fan inlet. The "normal" state is 1 (active). If the selected input switches to 0 (inactive), the action defined by parameter 4401 INLET PROT CTRL is executed after the delay set by parameter 4407 INLET CTRL DLY expires.</p> <p>0 = NOT SEL – No digital input selected. 1 = DI1 – Pump/fan inlet pressure monitored through digital input DI1. 2 = DI2 – See selection DI1. 3 = DI3 – See selection DI1. 4 = DI4 – See selection DI1. 5 = DI5 – See selection DI1.</p>				
4407	INLET CTRL DLY	0.1 ... 1800.0 s	1 = 0.1 s	60.0 s	
	Sets the delay after which the action defined by parameter 4401 INLET PROT CTRL is taken on detection of low inlet pressure.				
4408	INLET FORCED REF	-100.0 ... 100.0%	1 = 0.1%	0.0%	
	<p>This reference is used after detection of low inlet pressure. See parameter 4401 INLET PROT CTRL.</p> <p> WARNING! Make sure that it is safe to continue operation using this reference.</p>				

Group 44: Pump protection

Code	Description	Range	Resolution	Default	S
4409	<p>OUTLET PROT CTRL</p> <p>Enables, and selects the mode of, the primary supervision of pump/fan outlet pressure.</p> <p>Note: Outlet protection is active only when the active reference is PID.</p> <p>0 = NOT SEL – Primary outlet pressure supervision not used.</p> <p>1 = ALARM – Detection of high outlet pressure produces an alarm on the control panel display.</p> <p>2 = PROTECT – Detection of high outlet pressure produces an alarm on the control panel display. The output of the PI controller is ramped down (according to parameter 4417 PID OUT DEC TIME) to the forced reference (set by parameter 4416 OUTLET FORCED REF). The drive will revert to the original reference if the pressure subsequently falls below the supervision level.</p> <p>The following diagram describes the outlet pressure supervision function.</p> <p>3 = FAULT – Detection of high outlet pressure trips the drive on a fault.</p>				NOT SEL
	<p>The diagram consists of two vertically aligned graphs sharing a common time axis (t). The top graph plots 'Measured outlet pressure' and shows a curve that rises, then falls, then rises again. A horizontal dashed line at level 4413 represents the supervision limit. A horizontal dashed line at level 4411 represents the forced reference. A vertical dashed line marks the start of the pressure rise. A horizontal double-headed arrow labeled 4415 indicates the time delay between the pressure crossing the supervision limit and the forced reference being applied. The bottom graph plots 'EXT2 reference (from PID1OUT)'. It shows a step function that is high until the pressure crosses the supervision limit, then drops to a lower level (4416) for a duration marked by a horizontal double-headed arrow labeled 4417, before returning to the high level.</p>				
4410	<p>AI MEAS OUTLET</p> <p>Selects the analog input for pump/fan outlet pressure supervision.</p> <p>0 = NOT SEL – No analog input selected.</p> <p>1 = AI1 – Pump/fan outlet pressure monitored through analog input AI1.</p> <p>2 = AI2 – See selection AI1.</p>				NOT SEL
4411	<p>AI OUT HI LEVEL</p> <p>Sets the supervision limit for the primary outlet pressure measurement. If the value of the selected analog input exceeds this limit, the action defined by parameter 4409 OUTLET PROT CTRL is taken after a delay set with parameter 4415 OUTLET CTRL DLY expires. Supervision level</p>	0.00 ... 100.00%	1 = 0.01%	100.00%	
4412	<p>VERY HIGH CTRL</p> <p>Enables, and selects the mode of, the secondary outlet pressure supervision function. The function uses the analog input selected by parameter 4410 AI MEAS OUTLET.</p> <p>0 = NOT SEL – Secondary outlet pressure monitoring not used.</p> <p>1 = STOP – Detection of very high outlet pressure stops the drive. The drive will start again if the pressure falls below the supervision level.</p> <p>2 = FAULT – Detection of very high outlet pressure trips the drive on a fault.</p>				NOT SEL
4413	<p>AI OUT VERY HIGH</p> <p>Supervision level for secondary outlet pressure monitoring function. See parameter 4409 OUTLET PROT CTRL. Supervision level</p>	0.00 ... 100.00%	1 = 0.01%	100.00%	

Group 44: Pump protection					
Code	Description	Range	Resolution	Default	S
4414	<p>DI STATUS OUTLET</p> <p>Selects the digital input for connection of a pressure switch at the pump/fan outlet. The "normal" state is 1 (active). If the selected input switches to 0 (inactive), the action defined by parameter 4409 OUTLET PROT CTRL is taken after a delay set by parameter 4415 OUTLET CTRL DLY expires.</p> <p>0 = NOT SEL – No digital input selected. 1 = DI1 – Pump/fan outlet pressure monitored through digital input DI1. 2 = DI2 – See selection DI1. 3 = DI3 – See selection DI1. 4 = DI4 – See selection DI1. 5 = DI5 – See selection DI1.</p>			NOT SEL	
4415	<p>OUTLET CTRL DLY</p> <p>Sets the delay after which the action defined by parameter 4409 OUTLET PROT CTRL is taken on detection of high outlet pressure.</p>	0.1 ... 3600.0 s	1 = 0.1 s	60.0 s	
4416	<p>OUTLET FORCED REF</p> <p>This reference is used after detection of high outlet pressure. See parameter 4409 OUTLET PROT CTRL.</p> <p> WARNING! Make sure that it is safe to continue operation using this reference.</p>	-100.0 ... 100.0%	1 = 0.01%	0.0%	
4417	<p>PID OUT DEC TIME</p> <p>PI controller ramp-down time. See selection PROTECT for parameters 4401 INLET PROT CTRL and 4409 OUTLET PROT CTRL.</p>	0.0 ... 3800.0 s	1 = 0.1 s	60.0 s	
4418	<p>APPL PROFILE CTL</p> <p>This parameter and parameters 4419 PROFILE OUTP LIM and 4420 PROF LIMIT ON DLY provide the Application profile protection feature, based on long-term monitoring of an internal status signal. If the selected signal exceeds (and remains above) the supervision limit for a longer time than the set delay (parameter 4420 PROF LIMIT ON DLY), the internal status signal "PROFILE HIGH" is set to 1. The signal can be directed to a relay output (see parameter Group 14: Relay outputs).</p> <p>0 = NOT SEL – Not selected. 1 = CONTROL DEV1 – Signal 0126 PID 1 OUTPUT is monitored and compared to parameter 4419 PROFILE OUTP LIM. Monitoring the deviation between the reference and the actual value gives an indication of the general condition of the pump, piping and valves. 2 = CONTROL DEV2 – Signal 0127 PID 2 OUTPUT is monitored and compared to parameter 4419 PROFILE OUTP LIM. Monitoring the deviation between the reference and the actual value gives an indication of the general condition of the pump, piping and valves. 3 = APPL OUTPUT – Signal 0116 APPL BLK OUTPUT is monitored and compared to parameter 4419 PROFILE OUTP LIM. The signal constantly remaining at 100% may indicate a leak in the output piping.</p>			NOT SEL	
4419	<p>PROFILE OUTP LIM</p> <p>Supervision limit for the Application profile protection. See also description in parameter 4418 APPL PROFILE CTL.</p>	-500.0 ... 500.0%	1 = 0.1%	100.0%	

Group 44: Pump protection					
Code	Description	Range	Resolution	Default	S
4420	PROF LIMIT ON DLY Delay time for the Application profile protection. See also description in parameter 4418 APPL PROFILE CTL .	0.00 ... 100.00 h	1 = 0.01 h	0.00 h	
4421	PIPEFILL ENABLE Enables the Precharge function, which calculates reference steps. 0 = NOT SEL – Not enabled. 1 = DI1 – When DI1 is active (1), the Precharge function is active when the drive is started. If DI1 becomes inactive (0) before the Precharge function is finished, normal PID control is enabled. 2 = DI2 – See selection DI1. 3 = DI3 – See selection DI1. 4 = DI4 – See selection DI1. 5 = DI5 – See selection DI1. 7 = ACTIVE – The Precharge function is active at every start-up. -1 = DI1(INV) – When DI1 is inactive (0), the Precharge function is active when the drive is started. If DI1 becomes active (1) before the Precharge function is finished, normal PID control is enabled. -2 = DI2(INV) – See selection DI1(INV). -3 = DI3(INV) – See selection DI1(INV). -4 = DI4(INV) – See selection DI1(INV). -5 = DI5(INV) – See selection DI1(INV).			NOT SEL	
4422	PIPEFILL STEP Defines the speed step used in the Precharge function. The PID reference ramp time is specified by parameter 4032 PID REF ACC TIME . The speed step is added to the reference after the time defined by parameter 4424 ACT CHANGE DELAY has elapsed and the change in feedback defined by parameter 4423 REQ ACT CHANGE has not been reached. • Speed step in percent of the maximum speed output	0.0 ... 100.0%	1 = 0.1%	0.0%	
4423	REQ ACT CHANGE Defines the requested change in process feedback during the time that is set by parameter 4424 ACT CHANGE DELAY . If the requested change in the feedback is not reached, 4422 PIPEFILL STEP is added to the speed reference. • Value in percent of the maximum speed.	0.0 ... 100.0%	1 = 0.1%	0.0%	
4424	ACT CHANGE DELAY Defines the time that is waited after the feedback value is compared with the old feedback value. If parameter 4423 REQ ACT CHANGE is measured in the feedback value, the speed reference stays as it is. If REQ ACT CHANGE is not seen in the feedback value, the value of parameter 4422 PIPEFILL STEP is added to the speed reference.	0.1 ... 6000.0 s	1 = 0.1 s	0.0 s	

Group 44: Pump protection					
Code	Description	Range	Resolution	Default	S
4425	PID ENABLE DEV Defines the level when the Precharge function is disabled and PID is enabled. When the level is reached, PID is enabled. PID is executed as parameterized. If reference ramp times are set, they are used. • Value in percent of the maximum feedback.	0.0 ... 100.0%	1 = 0.1%	0.1%	
4426	PIPEFILL TIMEOUT Defines the maximum time the Precharge function is allowed to operate. If this time elapses, PID is preset and PID is allowed to run as it is parameterized – with or without reference ramps. 0 = NOT SEL - 1...60000 s: Max. Precharge operating time	1 ... 60000 s	1 = 1 s	NOT SEL	

■ Group 45: Energy saving

This group defines the set-up for calculation and optimization of energy savings.

Note: The values of saved energy parameters *0174 SAVED KWH*, *0175 SAVED MWH*, *0176 SAVED AMOUNT 1*, *0177 SAVED AMOUNT 2* and *0178 SAVED CO2* are derived from subtracting the drive's energy consumed from the direct-on-line (DOL) consumption calculated on the basis of parameter *4508 PUMP POWER*. As such, the accuracy of the values is dependent on the accuracy of the power estimate entered in that parameter.

Group 45: Energy saving					
Code	Description	Range	Resolution	Default	S
4501	ENERGY OPTIMIZER Enables or disables the energy optimizer, which optimizes the flux so that the total energy consumption and motor noise level are reduced when the drive operates below the nominal load. The total efficiency (motor and drive) can be improved by 1...10% depending on load torque and speed. 0 = OFF – Disabled. 1 = ON – Enabled.			OFF	
4502	ENERGY PRICE Price of energy per kWh. Used for reference when energy savings are calculated. See parameters <i>0174 SAVED KWH</i> , <i>0175 SAVED MWH</i> , <i>0176 SAVED AMOUNT 1</i> , <i>0177 SAVED AMOUNT 2</i> and <i>0178 SAVED CO2</i> (reduction in carbon dioxide emissions in tn).	0.00 ... 655.35	1 = 0.1 (Currency)	0.00 (Currency)	
4507	CO2 CONV FACTOR Conversion factor for converting energy into CO2 emissions (kg/kWh or tn/MWh). Used for multiplying the saved energy in MWh to calculate the value of parameter <i>0178 SAVED CO2</i> (reduction in carbon dioxide emissions in tn).	0.0 ... 10.0 tn/MWh	1 = 0.1 tn/MWh	0.5 tn/MWh	

Group 45: Energy saving					
Code	Description	Range	Resolution	Default	S
4508	<p>PUMP POWER</p> <p>Pump power when connected directly to supply (DOL). Used for reference when energy savings are calculated. See parameters 0174 SAVED KWH, 0175 SAVED MWH, 0176 SAVED AMOUNT 1, 0177 SAVED AMOUNT 2 and 0178 SAVED CO2.</p> <p>It is possible to use this parameter as the reference power also for other applications than pumps. The reference power can also be some other constant power than a motor connected directly on-line.</p>	0.0 ... 1000.0%	1 = 0.1%	100.0%	
4509	<p>ENERGY RESET</p> <p>Resets energy calculators 0174 SAVED KWH, 0175 SAVED MWH, 0176 SAVED AMOUNT 1, 0177 SAVED AMOUNT 2 and 0178 SAVED CO2.</p> <p>0 = DONE – Reset not requested (normal operation). 1 = RESET – Reset energy counters. The value reverts automatically to DONE.</p>			DONE	

■ Group 46: Pump cleaning

This group defines the set-up for pump cleaning.

Group 46: Pump cleaning					
Code	Description	Range	Resolution	Default	S
4601	PUMP CLEAN TRIG Defines how the Pump cleaning function is triggered. The pump cleaning sequence consists of forward and reverse “steps”.			NOT SEL	
	<p>WARNING! Before enabling the Pump cleaning function ensure it is safe to perform the Pump cleaning sequence with the connected equipment.</p> <p>Notes:</p> <ul style="list-style-type: none"> • The Pump cleaning function overrides parameter <i>1003 DIRECTION</i>. • The Pump cleaning function observes the maximum forward and reverse frequencies (parameters <i>2007 MINIMUM FREQ</i> and <i>2008 MAXIMUM FREQ</i>). • The Pump cleaning function always uses acceleration time 2 (parameter <i>2205 ACCELER TIME 2</i>) and deceleration time 2 (parameter <i>2206 DECELER TIME 2</i>). • The drive must be ready and its Run enable signal must be present before the Pump cleaning function sequence can start. <p>0 = NOT SEL – No triggering source defined. 1 = DI1 – Trigger on the rising edge of digital input DI1. 2 = DI2 – See selection DI1. 3 = DI3 – See selection DI1. 4 = DI4 – See selection DI1. 5 = DI5 – See selection DI1.</p>				

Group 46: Pump cleaning					
Code	Description	Range	Resolution	Default	S
	7 = DI1/SUP1OVR – Pump cleaning is started by rising edge of digital input DI1 or SUPRV1 OVER, not both at the same time. See parameter Group 32: Supervision . 8 = DI2/SUP1OVR – See selection DI1/SUP1OVR. 9 = DI3/SUP1OVR – See selection DI1/SUP1OVR. 10 = DI4/SUP1OVR – See selection DI1/SUP1OVR. 11 = DI5/SUP1OVR – See selection DI1/SUP1OVR. 12 = SUPRV1 OVER – Trigger on SUPRV1 OVER (parameter 1401 RELAY OUTPUT 1). See parameter Group 32: Supervision . 13 = DRIVE START – Trigger when the drive receives a start command. 14 = TIMER TRIG – Pump cleaning sequence is started periodically at intervals defined by parameter 4607 TRIG TIME . -1 = DI1(INV) – Trigger on the falling edge of digital input DI1. -2 = DI2(INV) – See selection DI1(INV). -3 = DI3(INV) – See selection DI1(INV). -4 = DI4(INV) – See selection DI1(INV). -5 = DI5(INV) – See selection DI1(INV). -7 = DI1(INV)S1O – Enable on the falling edge of digital input DI1, trigger on SUPRV1 OVER (parameter 1401 RELAY OUTPUT 1). See parameter Group 32: Supervision . -8 = DI2(INV)S1O – See selection DI1(INV)S1O. -9 = DI3(INV)S1O – See selection DI1(INV)S1O. -10 = DI4(INV)S1O – See selection DI1(INV)S1O. -11 = DI5(INV)S1O – See selection DI1(INV)S1O.				
4602	FWD STEP	0.0 ... 100.0%	1 = 0.1%	0.0%	
	Defines the forward step frequency for the pump cleaning sequence in percent of the nominal motor frequency (parameter 9907 MOTOR NOM FREQ).				
4603	REV STEP	0.0 ... 100.0%	1 = 0.1%	0.0%	
	Defines the reverse step frequency for the pump cleaning sequence in percent of the nominal motor frequency (parameter 9907 MOTOR NOM FREQ).				
4604	OFF TIME	0.0 ... 1000.0 s	1 = 0.1 s	0.0 s	
	Defines the length of the interval between forward and reverse steps in the pump cleaning sequence in seconds.				
4605	FWD TIME	0.0 ... 1000.0 s	1 = 0.1 s	0.0 s	
	Defines the duration of each forward step in the pump cleaning sequence in seconds.				
4606	REV TIME	0.0 ... 1000.0 s	1 = 0.1 s	0.0 s	
	Defines the duration of each reverse step in the pump cleaning sequence in seconds.				
4607	TRIG TIME	0.0 ... 200.0 h	1 = 0.1 h	0.0 h	
	Defines the time for setting TIMER TRIG of parameter 4601 PUMP CLEAN TRIG .				
4608	COUNT	0...100	1 = 1	0	
	Number of steps to be performed in the pump cleaning sequence.				

■ Group 52: Panel comm

This group defines the communication settings for the control panel port on the drive. Normally, when using the supplied control panel, there is no need to change settings in this group.

In this group, parameter modifications take effect on the next power-up.

Group 52: Panel comm					
Code	Description	Range	Resolution	Default	S
5201	STATION ID Defines the address of the drive. Two units with the same address are not allowed on-line. • Range: 1...247	1...247	1	1	
5202	BAUD RATE Defines the transfer rate of the link. 9.6 19.2 38.4 57.6 115.2	9.6 ... 115.2 kbits/s	-	9.6 kbits/s	
5203	PARITY Defines the use of parity and stop bit(s). The same setting must be used in all on-line stations. 0 = 8N1 – 8 data bits, no parity, one stop bit. 1 = 8N2 – 8 data bits, no parity, two stop bits. 2 = 8E1 – 8 data bits, even parity indication bit, one stop bit. 3 = 8O1 – 8 data bits, odd parity indication bit, one stop bit.	0...3	1	0	
5204	OK MESSAGES Number of valid messages received by the drive. During normal operation, this number increases constantly.	0...65535	1	-	
5205	PARITY ERRORS Number of characters with a parity error received from the Modbus link. If the number is high, check that the parity settings of the devices connected on the bus are the same. Note: High electromagnetic noise levels generate errors.	0...65535	1	-	
5206	FRAME ERRORS Number of characters with a framing error received by the Modbus link. If the number is high, check that the communication speed settings of the devices connected on the bus are the same. Note: High electromagnetic noise levels generate errors.	0...65535	1	-	
5207	BUFFER OVERRUNS Number of characters which overflow the buffer, in other words, number of characters which exceed the maximum message length, 128 bytes.	0...65535	1	-	

Group 52: Panel comm

Code	Description	Range	Resolution	Default	S
5208	CRC ERRORS Number of messages with a CRC (cyclic redundancy check) error received by the drive. If the number is high, check CRC calculation for possible errors. Note: High electromagnetic noise levels generate errors.	0...65535	1	-	S

■ Group 53: EFB protocol

This group defines set-up variables used for an embedded fieldbus (EFB) communication protocol. Refer to communication protocol documentation for more information on these parameters.

Group 53: EFB protocol

Code	Description	Range	Resolution	Default	S
5301	EFB PROTOCOL ID Contains the identification and program revision of the protocol. Note: You can reset this parameter only with parameter <i>9802 COMM PROT SEL</i> . • Format XXYY hex, where XX = protocol ID and YY = program revision of the protocol.	0000 ... FFFF hex	1	0000 hex	
5302	EFB STATION ID Defines the address of the device. Two units with the same address are not allowed on-line.	0...65535	1	1	✓
5303	EFB BAUD RATE Defines the transfer rate of the link. 1.2 kbits/s 2.4 kbits/s 4.8 kbits/s 9.6 kbits/s 19.2 kbits/s 38.4 kbits/s 57.6 kbits/s 76.8 kbits/s	1.2 ... 76.8 kbits/s	-	9.6 kbits/s	
5304	EFB PARITY Defines the use of parity and stop bit(s) and the data length. The same setting must be used in all on-line stations. 0 = 8 NONE 1 – 8 data bits, no parity, one stop bit. 1 = 8 NONE 2 – 8 data bits, no parity, two stop bits. 2 = 8 EVEN 1 – 8 data bits, even parity, one stop bit. 3 = 8 ODD 1 – 8 data bits, odd parity, one stop bit.	0...3		0	

Group 53: EFB protocol					
Code	Description	Range	Resolution	Default	S
5305	EFB CTRL PROFILE Selects the communication profile. See section Communication profiles on page 339. 0 = ABB DRV LIM – Operation of Control/Status words conforms to ABB Drives Profile. 1 = DCU PROFILE – Operation of Control/Status words conforms to 32-bit DCU Profile. 2 = ABB DRV FULL – Operation of Control/Status words conforms to ABB Drives Profile.	0...2	1	0	
5306	EFB OK MESSAGES Number of valid messages received by the drive. During normal operation, this number increases constantly.	0...65535	1	0	
5307	EFB CRC ERRORS Number of messages with a CRC (cyclic redundancy check) error received by the drive. If the number is high, check CRC calculation for possible errors. Note: High electromagnetic noise levels generate errors.	0...65535	1	0	
5308	EFB UART ERRORS Number of messages with a character error received by the drive.	0...65535	1	0	
5309	EFB STATUS Status of the EFB protocol. 0 = IDLE – EFB protocol is configured, but not receiving any messages. 1 = EXECUT INIT – EFB protocol is initializing. 2 = TIME OUT – A time-out has occurred in the communication between the network master and the EFB protocol. 3 = CONFIG ERROR – EFB protocol has a configuration error. 4 = OFF-LINE – EFB protocol is receiving messages that are NOT addressed to this drive. 5 = ON-LINE – EFB protocol is receiving messages that are addressed to this drive. 6 = RESET – EFB protocol is performing a hardware reset. 7 = LISTEN ONLY – EFB protocol is in listen-only mode.	0...7	1	0	
5310...	EFB PAR 10...	0...9999	1	Protocol dep.	
5320	EFB PAR 20				
5321	MDB DATA IN 1 Modbus register 40013 - Read only. Supported by STD Modbus only.	0...9999	1	0	
5322	MDB DATA IN 2 Modbus register 40014 - Read only. Supported by STD Modbus only.	0...9999	1	0	
5323	MDB DATA OUT 1 Modbus register 40080 - Write only. Supported by STD Modbus only.	0...9999	1	0	
5324	MDB DATA OUT 2 Modbus register 40081 - Write only. Supported by STD Modbus only.	0...9999	1	0	
5325	MDB DATA OUT 13 Modbus register 40082 - Write only. Supported by STD Modbus only.	0...9999	1	0	
5326	MDB DATA OUT 4 Modbus register 40083 - Write only. Supported by STD Modbus only.	0...9999	1	0	

Group 53: EFB protocol					
Code	Description	Range	Resolution	Default	S
5327	MDB DATA OUT 5 Modbus register 40084 - Write only. Supported by STD Modbus only.	0...9999	1	0	
5328	MDB DATA OUT 6 Modbus register 40085 - Write only. Supported by STD Modbus only.	0...9999	1	0	
5329	MDB DATA OUT 7 Modbus register 40086 - Write only. Supported by STD Modbus only.	0...9999	1	0	
5330	MDB DATA OUT 8 Modbus register 40087 - Write only. Supported by STD Modbus only.	0...9999	1	0	
5331	MDB DATA OUT 9 Modbus register 40088 - Write only. Supported by STD Modbus only.	0...9999	1	0	
5332	MDB DATA OUT 10 Modbus register 40089 - Write only. Supported by STD Modbus only.	0...9999	1	0	

■ Group 64: Load analyzer

This group defines the settings for the load analyzing function for peak value and amplitude. See section [Load analyzer](#) on page 138.

Group 64: Load analyzer					
Code	Description	Range	Resolution	Default	S
6401	PVL SIGNAL Defines the signal logged for peak value. Parameter index in Group 01: Operating data . For example, 102 = 0102 SPEED .	101...178		103	
6402	PVL FILTER TIME Defines the filter time for peak value logging. Filter time	0.0 ... 120.0 s	1 = 0.1 s	0.1 s	
6403	LOGGERS RESET Defines the source for the reset of loggers. 0 = NOT SEL – No reset selected. 1 = DI1 – Reset loggers on the rising edge of DI1. 2 = DI2 – See selection DI1. 3 = DI3 – See selection DI1. 4 = DI4 – See selection DI1. 5 = DI5 – See selection DI1. 7 = RESET – Reset loggers. Parameter is set to NOT SEL. -1 = DI1(INV) – Reset loggers on the falling edge of DI1. -2 = DI2(INV) – See selection DI1(INV). -3 = DI3(INV) – See selection DI1(INV). -4 = DI4(INV) – See selection DI1(INV). -5 = DI5(INV) – See selection DI1(INV).			NOT SEL	
6404	AL2 SIGNAL Defines the signal logged for amplitude logger 2. Parameter index in Group 01: Operating data . For example, 102 = 0102 SPEED .	101...178		103	

Group 64: Load analyzer					
Code	Description	Range	Resolution	Default	S
6405	AL2 SIGNAL BASE Defines the base value from which the percentage distribution is calculated. Representation and default value depends on the signal selected with parameter 6404 AL2 SIGNAL .	-		-	
6406	PEAK VALUE Detected peak value of the signal selected with parameter 6401 PVL SIGNAL .	-		-	
6407	PEAK TIME 1 Date of the peak value detection. Day on which the peak value was detected. Format: Date if the real time clock is operating. / The number of days elapsed after the power-on if the real time clock is not used, or was not set.	0 ... 65535 d	1 = 1 d	0 d	
6408	PEAK TIME 2 Time of the peak value detection.	00:00:00 ... 23:59:58		00:00:00	
6409	CURRENT AT PEAK Current at the moment of the peak value	0.0 ... 6553.5 A	1 = 0.1 A	0.0 A	
6410	UDC AT PEAK DC voltage at the moment of the peak value	0 ... 65535 V	1 = 1 V	0 V	
6411	FREQ AT PEAK Output frequency at the moment of the peak value	0.0 ... 6553.5 Hz	1 = 0.1 Hz	0.0 Hz	
6412	TIME OF RESET 1 Last reset date of the peak logger and amplitude logger 2. Day of the last reset. Format: Date if the real time clock is operating. / Number of days elapsed after the power-on if the real time clock is not used, or was not set.	0 ... 65535 d	1 = 1 d	0 d	
6413	TIME OF RESET 2 Last reset time of the peak logger and amplitude logger 2.	00:00:00 ... 23:59:58		00:00:00	
6414	AL1RANGE0TO10 Amplitude logger 1 (current in percent of nominal current) 0...10% distribution	0.0 ... 100.0%	1 = 0.1%	0.0%	
6415	AL1RANGE10TO20 Amplitude logger 1 (current in percent of nominal current) 10...20% distribution	0.0 ... 100.0%	1 = 0.1%	0.0%	
6416	AL1RANGE20TO30 Amplitude logger 1 (current in percent of nominal current) 20...30% distribution	0.0 ... 100.0%	1 = 0.1%	0.0%	
6417	AL1RANGE30TO40 Amplitude logger 1 (current in percent of nominal current) 30...40% distribution	0.0 ... 100.0%	1 = 0.1%	0.0%	
6418	AL1RANGE40TO50 Amplitude logger 1 (current in percent of nominal current) 40...50% distribution	0.0 ... 100.0%	1 = 0.1%	0.0%	
6419	AL1RANGE50TO60 Amplitude logger 1 (current in percent of nominal current) 40...50% distribution	0.0 ... 100.0%	1 = 0.1%	0.0%	
6420	AL1RANGE60TO70 Amplitude logger 1 (current in percent of nominal current) 40...50% distribution	0.0 ... 100.0%	1 = 0.1%	0.0%	

Group 64: Load analyzer					
Code	Description	Range	Resolution	Default	S
6421	AL1RANGE70TO80 Amplitude logger 1 (current in percent of nominal current) 40...50% distribution	0.0 ... 100.0%	1 = 0.1%	0.0%	
6422	AL1RANGE80TO90 Amplitude logger 1 (current in percent of nominal current) 40...50% distribution	0.0 ... 100.0%	1 = 0.1%	0.0%	
6423	AL1RANGE90TO Amplitude logger 1 (current in percent of nominal current) 40...50% distribution	0.0 ... 100.0%	1 = 0.1%	0.0%	
6424	AL2RANGE0TO10 Amplitude logger 2 (selection with parameter 6404) 0...10% distribution	0.0 ... 100.0%	1 = 0.1%	0.0%	
6425	AL2RANGE10TO20 Amplitude logger 2 (selection with parameter 6404) 10...20% distribution	0.0 ... 100.0%	1 = 0.1%	0.0%	
6426	AL2RANGE20TO30 Amplitude logger 2 (selection with parameter 6404) 20...30% distribution	0.0 ... 100.0%	1 = 0.1%	0.0%	
6427	AL2RANGE30TO40 Amplitude logger 2 (selection with parameter 6404) 30...40% distribution	0.0 ... 100.0%	1 = 0.1%	0.0%	
6428	AL2RANGE40TO50 Amplitude logger 2 (selection with parameter 6404) 40...50% distribution	0.0 ... 100.0%	1 = 0.1%	0.0%	
6429	AL2RANGE50TO60 Amplitude logger 2 (selection with parameter 6404) 50...60% distribution	0.0 ... 100.0%	1 = 0.1%	0.0%	
6430	AL2RANGE60TO70 Amplitude logger 2 (selection with parameter 6404) 60...70% distribution	0.0 ... 100.0%	1 = 0.1%	0.0%	
6431	AL2RANGE70TO80 Amplitude logger 2 (selection with parameter 6404) 70...80% distribution	0.0 ... 100.0%	1 = 0.1%	0.0%	
6432	AL2RANGE80TO90 Amplitude logger 2 (selection with parameter 6404) 80...90% distribution	0.0 ... 100.0%	1 = 0.1%	0.0%	
6433	AL2RANGE90TO Amplitude logger 2 (selection with parameter 6404) 90...100% distribution	0.0 ... 100.0%	1 = 0.1%	0.0%	

■ Group 81: PFA control

This group defines a Pump and Fan Alternation (PFA) mode of operation. The major features of PFA are:

- The ACS320 controls the motor of pump no. 1, varying the motor speed to control the pump capacity. This motor is the speed regulated motor.
- Direct line connections power the motor of pump no. 2 and pump no. 3, etc. The ACS320 switches pump no. 2 (and then pump no. 3, etc.) on and off as needed. These motors are auxiliary motors. Use of the MREL-01 relay output module is required for control of pump no. 2 and no. 3.
- The ACS320 PID control uses two signals: a process reference and an actual value feedback. The PID controller adjusts the speed (frequency) of the first pump such that the actual value follows the process reference.
- When demand (defined by the process reference) exceeds the first motor's capacity (user defined as a frequency limit), the PFA automatically starts an auxiliary pump. The PFA also reduces the speed of the first pump to account for the auxiliary pump's addition to total output. Then, as before, the PID controller adjusts the speed (frequency) of the first pump such that the actual value follows the process reference. If demand continues to increase, PFA adds additional auxiliary pumps, using the same process.
- When demand drops, such that the first pump speed falls below a minimum limit (user defined by a frequency limit), the PFA automatically stops an auxiliary pump. The PFA also increases the speed of the first pump to account for the auxiliary pump's missing output.
- An Interlock function (when enabled) identifies off-line (out of service) motors, and the PFA skips to the next available motor in the sequence.

An Autochange function (when enabled and with the appropriate switchgear) equalizes duty time between the pump motors. Autochange periodically increments the position of each motor in the rotation – the speed regulated motor becomes the last auxiliary motor, the first auxiliary motor becomes the speed regulated motor, etc.

Group 81: PFA control					
Code	Description	Range	Resolution	Default	S
8103	<p>REFERENCE STEP 1</p> <p>Sets a percentage value that is added to the process reference.</p> <ul style="list-style-type: none"> • Applies only when <u>at least one</u> auxiliary (constant speed) motor is running. • Default value is 0%. <p>Example: An ACS320 operates three parallel pumps that maintain water pressure in a pipe.</p> <ul style="list-style-type: none"> • Parameter 4011 INTERNAL SETPNT sets a constant pressure reference that controls the pressure in the pipe. • The speed regulated pump operates alone at low water consumption levels. • As water consumption increases, first one constant speed pump operates, then, the second. • As flow increases, the pressure at the output end of the pipe drops relative to the pressure measured at the input end. As auxiliary motors step in to increase the flow, the adjustments below correct the reference to more closely match the output pressure. • When the first auxiliary pump operates, increase the reference with parameter 8103 REFERENCE STEP 1. • When both auxiliary pumps operate, increase the reference with parameter 8103 REFERENCE STEP 1 + parameter 8104 REFERENCE STEP 2. • When three auxiliary pumps operate, increase the reference with parameter 8103 REFERENCE STEP 1 + parameter 8104 REFERENCE STEP 2 + parameter 8105 REFERENCE STEP 3. 	0.0 ... 100.0%	0.1%	0.0%	
8104	<p>REFERENCE STEP 2</p> <p>Sets a percentage value that is added to the process reference.</p> <ul style="list-style-type: none"> • Applies only when <u>at least two</u> auxiliary (constant speed) motors are running. • See parameter 8103 REFERENCE STEP 1. 	0.0 ... 100.0%	0.1%	0.0%	
8105	<p>REFERENCE STEP 3</p> <p>Sets a percentage value that is added to the process reference.</p> <ul style="list-style-type: none"> • Applies only when <u>at least three</u> auxiliary (constant speed) motors are running. • See parameter 8103 REFERENCE STEP 1. 	0.0 ... 100.0%	0.1%	0.0%	

Group 81: PFA control					
Code	Description	Range	Resolution	Default	S
8109	<p>START FREQ 1</p> <p>Sets the frequency limit used to start the first auxiliary motor. The first auxiliary motor starts if:</p> <ul style="list-style-type: none"> No auxiliary motors are running. ACS320 output frequency exceeds the limit: 8109 START FREQ 1 + 1 Hz. Output frequency stays above a relaxed limit (8109 START FREQ 1 - 1 Hz) for at least the time: 8115 AUX MOT START D. <p>After the first auxiliary motor starts:</p> <ul style="list-style-type: none"> Output frequency decreases by the value = (8109 START FREQ 1) - (8112 LOW FREQ 1). In effect, the output of the speed regulated motor drops to compensate for the input from the auxiliary motor. <p>See the figure, where:</p> <p>A = (8109 START FREQ 1) - (8112 LOW FREQ 1)</p> <p>B = Output frequency increase during the start delay.</p> <p>C = Diagram showing auxiliary motor's run status as frequency increases (1 = On).</p> <p>Note: 8109 START FREQ 1 value must be between:</p> <ul style="list-style-type: none"> 8112 LOW FREQ 1 (2008 MAXIMUM FREQ) - 1. 	0.0 ... 500.0 Hz	0.1 Hz	60.0	
8110	<p>START FREQ 2</p> <p>Sets the frequency limit used to start the second auxiliary motor.</p> <ul style="list-style-type: none"> See parameter 8109 START FREQ 1 for a complete description of the operation. <p>The second auxiliary motor starts if:</p> <ul style="list-style-type: none"> One auxiliary motor is running. ACS320 output frequency exceeds the limit: 8110 START FREQ 2 + 1. Output frequency stays above the relaxed limit (8110 START FREQ 2 - 1 Hz) for at least the time: 8115 AUX MOT START D. 	0.0 ... 500.0 Hz	0.1 Hz	60.0	

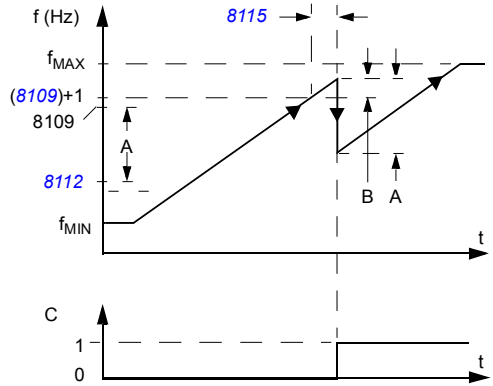

Group 81: PFA control					
Code	Description	Range	Resolution	Default	S
8113	LOW FREQ 2 Sets the frequency limit used to stop the second auxiliary motor. • See 8112 LOW FREQ 1 for a complete description of the operation. The second auxiliary motor stops if: • Two auxiliary motors are running. • Drive output frequency drops below the limit: 8113 LOW FREQ 2 - 1. • Output frequency stays below the relaxed limit (8113 LOW FREQ 2 + 1 Hz) for at least the time: 8116 AUX MOT STOP D .	0.0 ... 500.0 Hz	0.1 Hz	25.0	
8114	LOW FREQ 3 Sets the frequency limit used to stop the third auxiliary motor. • See 8112 LOW FREQ 1 for a complete description of the operation. The third auxiliary motor stops if: • Three auxiliary motors are running. • ACS320 output frequency drops below the limit: 8114 LOW FREQ 3 - 1. • Output frequency stays below the relaxed limit (8114 LOW FREQ 3 + 1 Hz) for at least the time: 8116 AUX MOT STOP D .	0.0 ... 500.0 Hz	0.1 Hz	25.0	
8115	AUX MOT START D Sets the Start delay for the auxiliary motors. • The output frequency must remain above the start frequency limit (parameter 8109 , 8110 , or 8111) for this time period before the auxiliary motor starts. • See 8109 START FREQ 1 for a complete description of the operation.	0.0 ... 3600.0 s	0.1 s; 1 s	5.0 s	
8116	AUX MOT STOP D Sets the Stop delay for the auxiliary motors. • The output frequency must remain below the low frequency limit (parameter 8112 , 8113 , or 8114) for this time period before the auxiliary motor stops. • See 8112 LOW FREQ 1 for a complete description of the operation.	0.0 ... 3600.0 s	0.1 s; 1 s	3.0 s	

Group 81: PFA control

Code	Description	Range	Resolution	Default	S
8117	<p>NR OF AUX MOT</p> <p>Sets the number of auxiliary motors. Each auxiliary motor requires a relay output, which the drive uses to send start/stop signals.</p> <p>The Autochange function, if used, requires an additional relay output for the speed regulated motor.</p> <p>The following describes the set-up of the required relay outputs.</p> <p>Relay outputs</p> <p>As noted above, each auxiliary motor requires a relay output, which the drive uses to send start/stop signals. The following describes how the drive keeps track of motors and relays.</p> <p>The drive provides one relay output RO1. An external relay output module can be added to provide relay outputs RO2...RO4.</p> <p>Note: If five auxiliary motors are used (Autochange disabled), use transistor output TO in addition to relay outputs RO1...RO4. Note that max. voltage at TO is 30 V DC.</p> <p>Parameters 1401...1403 and 1410 define, respectively, how relays RO1...RO4 are used – the parameter value 31 (PFA) defines the relay as used for PFA.</p> <p>The drive assigns auxiliary motors to relays in ascending order. If the Autochange function is disabled, the first auxiliary motor is the one connected to the first relay with a parameter setting = 31 (PFA), and so on.</p> <p>If the Autochange function is used, the assignments rotate. Initially, the speed regulated motor is the one connected to the first relay with a parameter setting = 31 (PFA), the first auxiliary motor is the one connected to the second relay with a parameter setting = 31 (PFA), and so on. The fourth auxiliary motor uses the same reference step, low frequency and start frequency values as the third auxiliary motor. Number of auxiliary motors.</p>	0...4 (5 with TO)	1 = 1	1	✓

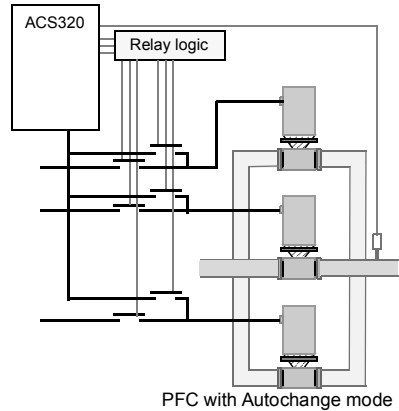
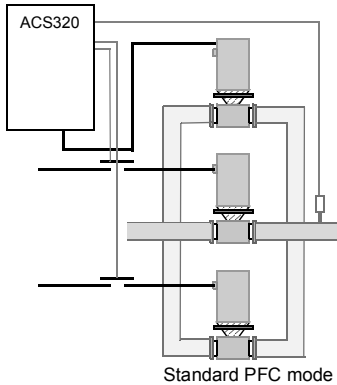

Group 81: PFA control									
Code	Description	Range	Resolution	Default	S				
	The table below shows the PFA motor assignments for some typical settings in the relay output parameters (<i>1401...1403</i> and <i>1410</i>), where the settings are either = 31 (), or =X (anything but 31), and where the Autochange function is disabled (<i>8118 AUTOCHNG INTERV</i> = 0).								
Parameter setting					Relay assignment				
1401	1402	1403	1410	8117	Autochange disabled				
					RO1	RO2	RO3	RO4	
31	X	X	X	1	Aux.	X	X	X	
31	31	X	X	2	Aux.	Aux.	X	X	
31	31	31	X	3	Aux.	Aux.	Aux.	X	
X	31	31	X	2	X	Aux.	Aux.	X	
31	31	X	X	1*	Aux.	Aux.	X	X	
* = One additional relay output for the PFC that is in use. One motor is in "sleep" when the other is rotating.									
	The table below shows the PFA motor assignments for some typical settings in the relay output parameters (<i>1401...1403</i> and <i>1410</i>), where the settings are either = 31 (), or =X (anything but 31), and where the Autochange function is enabled (<i>8118 AUTOCHNG INTERV</i> > 0).								
Parameter setting					Relay assignment				
1401	1402	1403	1410	8117	Autochange enabled				
					RO1	RO2	RO3	RO4	
31	31	X	X	1	PFA	PFA	X	X	
31	31	31	X	2	PFA	PFA	PFA	X	
X	31	31	X	1	X	PFA	PFA	X	
31	31	X	X	0**	PFA	PFA	X	X	
** = No auxiliary motors, but the Autochange function is in use. Working as a standard PID-control.									

Group 81: PFA control

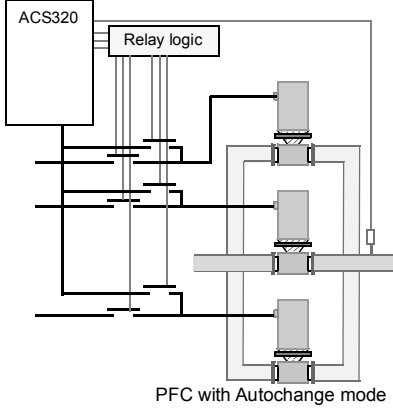
Code	Description	Range	Resolution	Default	S
8118	<p>AUTOCHNG INTERV</p> <p>Controls operation of the Autochange function and sets the interval between changes. The Autochange time interval only applies to the time when the speed regulated motor is running.</p> <p>See parameter 8119 AUTOCHNG LEVEL for an overview of the Autochange function. The drive always coasts to stop when the Autochange function is performed. The Autochange enabled selection requires parameter 8120 INTERLOCKS > 0.</p> <p>⚠ WARNING! When enabled, the Autochange function requires the interlocks (8120 INTERLOCKS > 0) enabled. During the Autochange function the power output is interrupted and the drive coasts to stop, preventing damage to the contacts.</p>	0.1 ... 336.0 h	1 = 0.1 h	NOT SEL	
	 <p style="text-align: center;">PFC with Autochange mode</p>				
	<p>-0.1 = TEST MODE – Forces the interval to value 36...48 s. 0.0 = NOT SEL – Disables the Autochange function. The operating time interval (the time when the start signal is on) between automatic motor changes.</p>				

Group 81: PFA control					
Code	Description	Range	Resolution	Default	S
8119	<p>AUTOCHNG LEVEL</p> <p>Sets an upper limit, as a percent of output capacity, for the autochange logic. When the output from the PID/PFA control block exceeds this limit, the Autochange function is prevented. For example, use this parameter to deny the Autochange function when the Pump-Fan system is operating near maximum capacity.</p> <p>Autochange overview</p> <p>The purpose of the autochange operation is to equalize duty time between multiple motors used in a system. At each autochange operation:</p> <ul style="list-style-type: none"> • A different motor takes a turn connected to the ACS320 output – the speed regulated motor. • The starting order of the other motors rotates. <p>The Autochange function requires:</p> <ul style="list-style-type: none"> • External switchgear for changing the drive's output power connections. • Parameter 8120 INTERLOCKS = value > 0. <p>The Autochange function is performed when:</p> <ul style="list-style-type: none"> • The running time since the previous autochange operation reaches the time set by 8118 AUTOCHNG INTERV. • The PFA input is below the level set by this parameter, 8119 AUTOCHNG LEVEL. <p>Note: The ACS320 always coasts to stop when autochange operation is performed.</p> <p>In an autochange operation, the Autochange function does all of the following (see the figure below):</p> <ul style="list-style-type: none"> • Initiates a change when the running time, since the last autochange operation, reaches 8118 AUTOCHNG INTERV, and PFA input is below limit 8119 AUTOCHNG LEVEL. • Stops the speed regulated motor. • Switches off the contactor of the speed regulated motor. • Increments the starting order counter, to change the starting order for the motors. • Identifies the next motor in line to be the speed regulated motor. • Switches off the above motor's contactor, if the motor was running. Any other running motors are not interrupted. • Switches on the contactor of the new speed regulated motor. The autochange switchgear connects this motor to the ACS320 power output. • Delays motor start for the time 8122 PFA START DELAY. 	0.0 ... 100.0%	0.1%	50.0%	

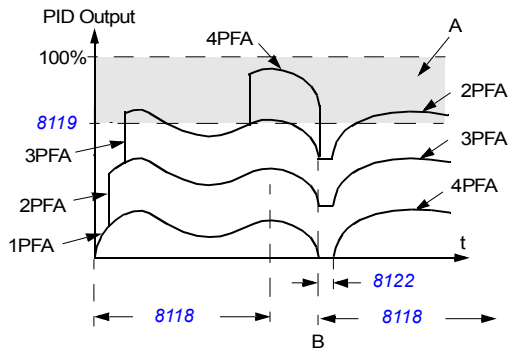

A = Area above **8119 AUTOCHNG LEVEL** – autochange operation not allowed.

B = Autochange operation occurs.

1PFA, etc. = PID output associated with each motor.

Group 81: PFA control

Code	Description	Range	Resolution	Default	S
	<ul style="list-style-type: none"> Starts the speed regulated motor. Identifies the next constant speed motor in the rotation. Switches the above motor on, but only if the new speed regulated motor had been running (as a constant speed motor) – This step keeps an equal number of motors running before and after autochange operation. Continues with a normal PFA operation. <p>Starting order counter</p> <p>The operation of the starting-order counter:</p> <ul style="list-style-type: none"> The relay output parameter definitions (1401...1403 and 1410) establish the initial motor sequence. (The lowest parameter number with a value 31 (PFA) identifies the relay connected to 1PFA, the first motor, and so on.) Initially, 1PFA = speed regulated motor, 2PFA = 1st auxiliary motor, etc. The first autochange operation shifts the sequence to: 2PFA = speed regulated motor, 3PFA = 1st auxiliary motor, ..., 1PFA = last auxiliary motor. The next autochange operation shifts the sequence again, and so on. If the autochange operation cannot start a needed motor because all inactive motors are interlocked, the drive displays an alarm (2015 PFC / LOCK). When the ACS320 power supply is switched off, the counter preserves the current autochange rotation positions in permanent memory. When power is restored, the autochange rotation starts at the position stored in memory. If the PFA relay configuration is changed (or if the PFA enable value is changed), the rotation is reset. (See the first bullet above.) 				

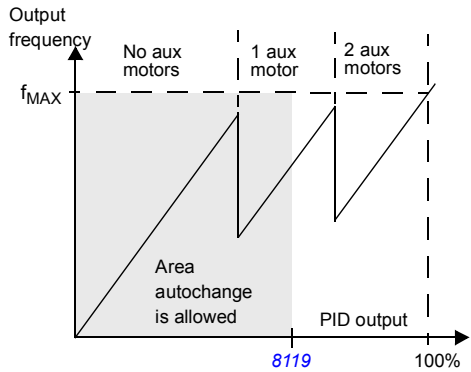

Group 81: PFA control																							
Code	Description	Range	Resolution	Default	S																		
8120	<p>INTERLOCKS</p> <p>Defines operation of the Interlock function. When the Interlock function is enabled:</p> <ul style="list-style-type: none"> • An interlock is active when its command signal is absent. • An interlock is inactive when its command signal is present. <p>The drive will not start if a start command occurs when the speed regulated motor's interlock is active – the control panel displays alarm 2015 PFC / LOCK.</p> <p>Wire each Interlock circuit as follows:</p> <ul style="list-style-type: none"> • Wire a contact of the motor's On/Off switch to the Interlock circuit – the drive's PFA logic can then recognize that the motor is switched off, and start the next available motor. • Wire a contact of the motor thermal relay (or other protective device in the motor circuit) to the Interlock input – the drive's PFA logic can then recognize that a motor fault is activated and stop the motor. <p>0 = NOT SEL – Disables the Interlock function. All digital inputs are available for other purposes.</p> <ul style="list-style-type: none"> • Requires parameter 8118 AUTOCHNG INTERV = 0 (The Autochange function must be disabled if the Interlock function is disabled.) <p>1 = DI1 – Enables the Interlock function, and assigns a digital input (starting with DI1) to the interlock signal for each PFA relay. These assignments are defined in the following table and depend on:</p> <p>The number of PFA relays (number of parameters 1401...1403 and 1410) with value = 31 (PFA)</p> <p>The Autochange function status (disabled if 8118 AUTOCHNG INTERV = 0, and otherwise enabled).</p> <table border="1"> <thead> <tr> <th>No. PFA relays</th> <th>Autochange disabled (8118)</th> <th>Autochange enabled (8118)</th> </tr> </thead> <tbody> <tr> <td>0</td> <td>DI1: Speed Reg Motor DI2...DI5: Free</td> <td>Not allowed</td> </tr> <tr> <td>1</td> <td>DI1: Speed Reg Motor DI2: First PFA Relay DI3...DI5: Free</td> <td>DI1: First PFA Relay DI2...DI5: Free</td> </tr> <tr> <td>2</td> <td>DI1: Speed Reg Motor DI2: First PFA Relay DI3: Second PFA Relay DI4...DI5: Free</td> <td>DI1: First PFA Relay DI2: Second PFA Relay DI3...DI5: Free</td> </tr> <tr> <td>3</td> <td>DI1: Speed Reg Motor DI2: First PFA Relay DI3: Second PFA Relay DI4: Third PFA Relay DI5...DI5: Free</td> <td>DI1: First PFA Relay DI2: Second PFA Relay DI3: Third PFA Relay DI4...DI5: Free</td> </tr> <tr> <td>4</td> <td>DI1: Speed Reg Motor DI2: First PFA Relay DI3: Second PFA Relay DI4: Third PFA Relay DI5: Fourth PFA Relay</td> <td>DI1: First PFA Relay DI2: Second PFA Relay DI3: Third PFA Relay DI4: Fourth PFA Relay DI5...DI5: Free</td> </tr> </tbody> </table>	No. PFA relays	Autochange disabled (8118)	Autochange enabled (8118)	0	DI1: Speed Reg Motor DI2...DI5: Free	Not allowed	1	DI1: Speed Reg Motor DI2: First PFA Relay DI3...DI5: Free	DI1: First PFA Relay DI2...DI5: Free	2	DI1: Speed Reg Motor DI2: First PFA Relay DI3: Second PFA Relay DI4...DI5: Free	DI1: First PFA Relay DI2: Second PFA Relay DI3...DI5: Free	3	DI1: Speed Reg Motor DI2: First PFA Relay DI3: Second PFA Relay DI4: Third PFA Relay DI5...DI5: Free	DI1: First PFA Relay DI2: Second PFA Relay DI3: Third PFA Relay DI4...DI5: Free	4	DI1: Speed Reg Motor DI2: First PFA Relay DI3: Second PFA Relay DI4: Third PFA Relay DI5: Fourth PFA Relay	DI1: First PFA Relay DI2: Second PFA Relay DI3: Third PFA Relay DI4: Fourth PFA Relay DI5...DI5: Free	0...5	1	4	
No. PFA relays	Autochange disabled (8118)	Autochange enabled (8118)																					
0	DI1: Speed Reg Motor DI2...DI5: Free	Not allowed																					
1	DI1: Speed Reg Motor DI2: First PFA Relay DI3...DI5: Free	DI1: First PFA Relay DI2...DI5: Free																					
2	DI1: Speed Reg Motor DI2: First PFA Relay DI3: Second PFA Relay DI4...DI5: Free	DI1: First PFA Relay DI2: Second PFA Relay DI3...DI5: Free																					
3	DI1: Speed Reg Motor DI2: First PFA Relay DI3: Second PFA Relay DI4: Third PFA Relay DI5...DI5: Free	DI1: First PFA Relay DI2: Second PFA Relay DI3: Third PFA Relay DI4...DI5: Free																					
4	DI1: Speed Reg Motor DI2: First PFA Relay DI3: Second PFA Relay DI4: Third PFA Relay DI5: Fourth PFA Relay	DI1: First PFA Relay DI2: Second PFA Relay DI3: Third PFA Relay DI4: Fourth PFA Relay DI5...DI5: Free																					
<p>Note: MREL-01 required for PFA relays 2, 3 and 4.</p>																							

Group 81: PFA control

Code	Description	Range	Resolution	Default	S
	<p>2 = DI2 – Enables the Interlock function, and assigns a digital input (starting with DI2) to the interlock signal for each PFA relay. These assignments are defined in the following table and depend on:</p> <ul style="list-style-type: none"> The number of PFA relays (number of parameters <i>1401...1403</i> and <i>1410</i>) with value = 31 (PFA). The Autochange function status (disabled if <i>8118 AUTOCHNG INTERV</i> = 0, and otherwise enabled). 				
	No. PFA relays	Autochange disabled (8118)	Autochange enabled (8118)		
	0	DI1: Free DI2: Speed Reg Motor DI3...DI5: Free	Not allowed		
	1	DI1: Free DI2: Speed Reg Motor DI3: First PFA Relay DI4...DI5: Free	DI1: Free DI2: First PFA Relay DI3...DI5: Free		
	2	DI1: Free DI2: Speed Reg Motor DI3: First PFA Relay DI4: Second PFA Relay DI5...DI5: Free	DI1: Free DI2: First PFA Relay DI3: Second PFA Relay DI4...DI5: Free		
	3	DI1: Free DI2: Speed Reg Motor DI3: First PFA Relay DI4: Second PFA Relay DI5: Third PFA Relay	DI1: Free DI2: First PFA Relay DI3: Second PFA Relay DI4: Third PFA Relay DI5...DI5: Free		
	4	DI1: Free DI2: Speed Reg Motor DI3: First PFA Relay DI4: Second PFA Relay DI5: Third PFA Relay	DI1: Free DI2: First PFA Relay DI3: Second PFA Relay DI4: Third PFA Relay DI5: Fourth PFA Relay		
	<p>Note: MREL-01 required for PFA relays 2, 3 and 4.</p>				
	<p>3 = DI3 – Enables the Interlocks function, and assigns a digital input (starting with DI3) to the interlock signal for each PFA relay. These assignments are defined in the following table and depend on:</p> <ul style="list-style-type: none"> The number of PFA relays (number of parameters <i>1401...1403</i> and <i>1410</i>) with value = 31 (PFA). The Autochange function status (disabled if <i>8118 AUTOCHNG INTERV</i> = 0, and otherwise enabled). 				

Group 81: PFA control					
Code	Description	Range	Resolution	Default	S
	No. PFA relays	Autochange disabled (8118)	Autochange enabled (8118)		
	0	DI1...DI2: Free DI3: Speed Reg Motor DI4...DI5: Free	Not allowed		
	1	DI1...DI2: Free DI3: Speed Reg Motor DI4: First PFA Relay DI5...DI5: Free	DI1...DI2: Free DI3: First PFA Relay DI4...DI5: Free		
	2	DI1...DI2: Free DI3: Speed Reg Motor DI4: First PFA Relay DI5: Second PFA Relay	DI1...DI2: Free DI3: First PFA Relay DI4: Second PFA Relay DI5...DI5: Free		
	3	DI1...DI2: Free DI3: Speed Reg Motor DI4: First PFA Relay DI5: Second PFA Relay	DI1...DI2: Free DI3: First PFA Relay DI4: Second PFA Relay DI5: Third PFA Relay		
	4	Not allowed	DI1...DI2: Free DI3: First PFA Relay DI4: Second PFA Relay DI5: Third PFA Relay		
Note: MREL-01 required for PFA relays 2, 3 and 4.					
4 = DI4 – Enables the Interlock function, and assigns a digital input (starting with DI4) to the interlock signal for each PFA relay. These assignments are defined in the following table and depend on:					
<ul style="list-style-type: none"> The number of PFA relays (number of parameters 1401...1403 and 1410) with value = 31 (PFA). The Autochange function status (disabled if 8118 AUTOCHNG INTERV = 0) 					
	No. PFA relays	Autochange disabled (8118)	Autochange enabled (8118)		
	0	DI1...DI3: Free DI4: Speed Reg Motor DI5...DI5: Free	Not allowed		
	1	DI1...DI3: Free DI4: Speed Reg Motor DI5: First PFA Relay	DI1...DI3: Free DI4: First PFA Relay DI5...DI5: Free		
	2	DI1...DI3: Free DI4: Speed Reg Motor DI5: First PFA Relay	DI1...DI3: Free DI4: First PFA Relay DI5: Second PFA Relay		
	3	Not allowed	DI1...DI3: Free DI4: First PFA Relay DI5: Second PFA Relay		
	4	Not allowed	Not allowed		

Group 81: PFA control

Code	Description	Range	Resolution	Default	S															
	<p>5 = DI5 – Enables the Interlock function, and assigns a digital input (starting with DI5) to the interlock signal for each PFA relay. These assignments are defined in the following table and depend on:</p> <ul style="list-style-type: none"> The number of PFA relays (number of parameters 1401...1403 and 1410) with value = 31 (PFA). The Autochange function status (disabled if 8118 AUTOCHNG INTERV = 0, and otherwise enabled). 																			
		<table border="1"> <thead> <tr> <th>No. PFA relays</th> <th>Autochange disabled (8118)</th> <th>Autochange enabled (8118)</th> </tr> </thead> <tbody> <tr> <td>0</td> <td>DI1...DI4: Free DI5: Speed Reg Motor</td> <td>Not allowed</td> </tr> <tr> <td>1</td> <td>DI1...DI4: Free DI5: Speed Reg Motor</td> <td>DI1...DI4: Free DI5: First PFA Relay</td> </tr> <tr> <td>2</td> <td>Not allowed</td> <td>DI1...DI4: Free DI5: First PFA Relay</td> </tr> <tr> <td>3...5</td> <td>Not allowed</td> <td>Not allowed</td> </tr> </tbody> </table>	No. PFA relays	Autochange disabled (8118)	Autochange enabled (8118)	0	DI1...DI4: Free DI5: Speed Reg Motor	Not allowed	1	DI1...DI4: Free DI5: Speed Reg Motor	DI1...DI4: Free DI5: First PFA Relay	2	Not allowed	DI1...DI4: Free DI5: First PFA Relay	3...5	Not allowed	Not allowed			
No. PFA relays	Autochange disabled (8118)	Autochange enabled (8118)																		
0	DI1...DI4: Free DI5: Speed Reg Motor	Not allowed																		
1	DI1...DI4: Free DI5: Speed Reg Motor	DI1...DI4: Free DI5: First PFA Relay																		
2	Not allowed	DI1...DI4: Free DI5: First PFA Relay																		
3...5	Not allowed	Not allowed																		

<p>8121 REG BYPASS CTRL</p> <p>Selects the Regulator by-pass control. When enabled, the Regulator by-pass control provides a simple control mechanism without a PID regulator.</p> <ul style="list-style-type: none"> Use the Regulator by-pass control only in special applications. <p>0 = NO – Disables the Regulator by-pass control. The drive uses the normal PFA reference: 1106 REF2 SELECT.</p> <p>1 = YES – Enables the Regulator by-pass control.</p> <ul style="list-style-type: none"> The process PID regulator is bypassed. Actual value of PID is used as the PFA reference (input). Normally EXT REF2 is used as the PFA reference. The drive uses the feedback signal defined by 4014 FBK SEL (or 4114) for the PFA frequency reference. The figure shows the relation between the control signal 4014 FBK SEL (or 4114) and the speed regulated motor's frequency in a three-motor system. 	<p>0...1 1 0</p> <p>A = No auxiliary motors running B = One auxiliary motor running C = Two auxiliary motors running</p>
--	---

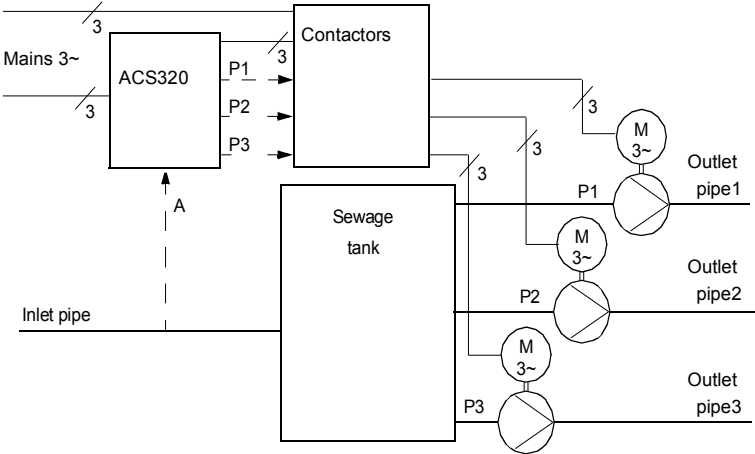
Group 81: PFA control					
Code	Description	Range	Resolution	Default	S
	<p>Example: In the diagram below, the pumping station's outlet flow is controlled by the measured inlet flow (A).</p> 				
8122	<p>PFA START DELAY</p> <p>Sets the start delay for speed regulated motors in the system. Using the delay, the drive works as follows:</p> <ul style="list-style-type: none"> • Switches on the contactor of the speed regulated motor – connecting the motor to the drive power output. • Delays motor start for the time 8122 PFA START DELAY. • Starts the speed regulated motor. • Starts auxiliary motors. See parameter 8115 AUX MOT START D for delay. <p>Warning! Motors equipped with star-delta starters require a PFA start delay.</p> <ul style="list-style-type: none"> • After the drive relay output switches a motor On, the star-delta starter must switch to the star-connection and then back to the delta-connection before the drive applies power. • So, the PFA start delay must be longer than the time setting of the star-delta starter. 	0.00 ... 10.00 s	0.01 s	0.50 s	

Group 81: PFA control					
Code	Description	Range	Resolution	Default	S
8123	<p>PFA ENABLE</p> <p>Sets the start delay for speed regulated motors in the system. Using the delay, the drive works as follows:</p> <ul style="list-style-type: none"> • Switches on the contactor of the speed regulated motor – connecting the motor to the drive power output. • Delays motor start for the time 8122 PFA START DELAY. • Starts the speed regulated motor. • Starts auxiliary motors. See parameter 8115 AUX MOT START D for delay. <p> WARNING! Motors equipped with star-delta starters require a PFA start delay.</p> <ul style="list-style-type: none"> • After the drive relay output switches a motor On, the star-delta starter must switch to the star-connection and then back to the delta-connection before the drive applies power. • So, the PFA start delay must be longer than the time setting of the star-delta starter. <p>1 = ACTIVE – PFA control enabled. 2 = SPFC ACTIVE – SPFC control enabled. The soft pump and fan control is used for alternation applications where lower pressure peaks are desirable when a new auxiliary motor is started. 3 = SPFC+AUTOCHG – SPFC control with autochange is enabled. Autochange with soft pump and fan control (SPFC) is active only when auxiliary motors are not running. The speed regulated motor is alternated according to the autochange logic.</p>	0...3	-	0	✓

Group 81: PFA control					
Code	Description	Range	Resolution	Default	S
8124	<p>ACC IN AUX STOP</p> <p>Sets the PFA acceleration time for a zero-to-maximum frequency ramp. This PFA acceleration ramp:</p> <ul style="list-style-type: none"> • Applies to the speed regulated motor, when an auxiliary motor is switched off. • Replaces the acceleration ramp defined in Group 22: Accel / Decel. • Applies only until the output of the regulated motor increases by an amount equal to the output of the switched off auxiliary motor. Then the acceleration ramp defined in Group 22: Accel / Decel applies. <p>0 = NOT SEL 0.1...1800 = Activates this function using the value entered as the acceleration time.</p> <p>The graph consists of two vertically aligned plots sharing a common time axis (t). The top plot shows the output frequency f_{OUT}. It starts with a linear ramp up labeled 'A'. At a certain point, the auxiliary motor starts (indicated by a vertical dashed line and parameter 8125). At this moment, the speed regulated motor's frequency begins to decrease, following a ramp down labeled 'B'. When the auxiliary motor stops (indicated by another vertical dashed line and parameter 8124), the speed regulated motor's frequency begins to increase again, following a ramp up. The bottom plot shows the auxiliary motor's state, with a step function from 0 to 1 corresponding to the auxiliary motor's operation.</p> <ul style="list-style-type: none"> • A = speed regulated motor accelerating using Group 22: Accel/Decel parameters (2202 or 2205). • B = speed regulated motor decelerating using Group 22: Accel/Decel parameters (2203 or 2206). • At aux. motor start, speed regulated motor decelerates using parameter 8125 DEC IN AUX START. At aux. motor stop, speed regulated motor accelerates using parameter 8124 ACC IN AUX STOP. 	0.0 ... 1800.0 s	0.1 s	0.0	
8125	<p>DEC IN AUX START</p> <p>Sets the PFA deceleration time for a maximum-to-zero frequency ramp. This PFA deceleration ramp:</p> <ul style="list-style-type: none"> • Applies to the speed regulated motor, when an auxiliary motor is switched on. • Replaces the deceleration ramp defined in Group 22: Accel/Decel. • Applies only until the output of the regulated motor decreases by an amount equal to the output of the auxiliary motor. Then the deceleration ramp defined in Group 22: Accel/Decel applies. <p>0 = NOT SEL 0.1...1800 = Activates this function using the value entered as the acceleration time.</p>	0.0 ... 1800.0 s	0.1 s	0.0	

Group 81: PFA control					
Code	Description	Range	Resolution	Default	S
8126	<p>TIMED AUTOCHANGE</p> <p>Sets the Autochange function with timer. When enables, the Autochange function is controlled with the timer functions.</p> <p>0 = NOT SEL. 1 = TIMER 1 – Enables the Autochange function when Timer 1 is active. 2...4 TIMER 2...4 – Enables the Autochange function when Timer 2...4 is active.</p>	0...4	1	0	
8127	<p>MOTORS</p> <p>Sets the actual number of PFA controlled motors (maximum 6 motors, 1 speed regulated, 3 connected direct-on-line and 3 spare motors).</p> <ul style="list-style-type: none"> • This value includes also the speed regulated motor. • This value must be compatible with number of relays allocated to PFA if the Autochange function is used. • If Autochange function is not used, the speed regulated motor does not need to have a relay output allocated to PFA but it needs to be included in this value. 	1...7	1	1	✓
8128	<p>AUX START ORDER</p> <p>Sets the start order of the auxiliary motors.</p> <p>1 = EVEN RUNTIME – Time sharing is active. Evens out the cumulative run time of the auxiliary motors. The start order depends on the run times: The auxiliary motor whose cumulative run time is shortest is started first, then the motor whose cumulative run time is the second shortest etc. When the demand drops, the first motor to be stopped is the one whose cumulative run time is longest.</p> <p>2 = RELAY ORDER – The start order is fixed to be the order of the relays.</p>				

■ Group 98: Options

This group configures for options, in particular, enabling serial communication with the drive.

Group 98: Options					
Code	Description	Range	Resolution	Default	S
9802	<p>COMM PROT SEL</p> <p>Selects the communication protocol.</p> <p>0 = NOT SEL – No communication protocol selected. 1 = STD MODBUS – The drive communicates with Modbus through the EIA-485 channel (X1-communications, terminal). • See also Group 53: EFB protocol. 2 = N2 – Enables fieldbus communication with the drive using Metasys N2 protocol through the EIA-485 serial link (X1-communications terminal). 3 = FLN – Enables fieldbus communication with the drive using FLN protocol through the EIA-485 serial link (X1-communications terminal). 5 = BACNET – Enables fieldbus communication with the drive using BACnet protocol through the EIA-485 serial link (X1-communications terminal). 10 = MODBUS RS232</p>	0...10	1	1	

Default values with different macros

When application macro is changed ([9902 APPLIC MACRO](#)), the software updates the parameter values to their default values. The table below shows the parameter default values for different macros. For other parameters, the default values are the same for all macros. See the parameter list starting on page [150](#).

Index	Name/ Selection	HVACDEFAULT	SUPPLY FAN	RETURN FAN	CLNG TWR FAN	CONDENSER
9902	APPLIC MACRO	1 = HVAC DEFAULT	2 = SUPPLY FAN	3 = RETURN FAN	4 = CLNG TWR FAN	5 = CONDENSER
1001	EXT1 COMMANDS	1 = DI1	1 = DI1	1 = DI1	1 = DI1	1 = DI1
1002	EXT2 COMMANDS	1 = DI1	1 = DI1	1 = DI1	1 = DI1	1 = DI1
1102	EXT1/EXT2 SEL	0 = EXT1	0 = EXT1	0 = EXT1	0 = EXT1	0 = EXT1
1103	REF1 SELECT	1 = AI1	1 = AI1	1 = AI1	1 = AI1	1 = AI1
1106	REF2 SELECT	19 = PID1OUT	19 = PID1OUT	19 = PID1OUT	19 = PID1OUT	19 = PID1OUT
1201	CONST SPEED SEL	3 = DI3	3 = DI3	3 = DI3	3 = DI3	3 = DI3
1401	RELAY OUTPUT 1	1 = READY	7 = STARTED	7 = STARTED	1 = READY	1 = READY
1601	RUN ENABLE	0 = NOT SEL	2 = DI2	0 = NOT SEL	0 = NOT SEL	0 = NOT SEL
1604	FAULT RESET SEL	0 = KEYPAD	0 = KEYPAD	0 = KEYPAD	0 = KEYPAD	0 = KEYPAD
1608	START ENABLE 1	4 = DI4	4 = DI4	4 = DI4	4 = DI4	4 = DI4
1609	START ENABLE 2	0 = NOT SEL	5 = DI5	5 = DI5	0 = NOT SEL	0 = NOT SEL
2007	MINIMUM FREQ	0.0 Hz	0.0 Hz	0.0 Hz	20.0 Hz	0.0 Hz
2101	START FUNCTION	6 = SCAN START	6 = SCAN START	6 = SCAN START	6 = SCAN START	6 = SCAN START
2108	START INHIBIT	0 = OFF	0 = OFF	0 = OFF	0 = OFF	0 = OFF
2202	ACCELER TIME 1	30.0 s	30.0 s	30.0 s	30.0 s	30.0 s
2203	DECELER TIME 1	30.0 s	30.0 s	30.0 s	30.0 s	30.0 s
3018	COMM FAULT FUNC	0 = NOT SEL	0 = NOT SEL	0 = NOT SEL	0 = NOT SEL	0 = NOT SEL
3415	SIGNAL3 PARAM	120	120	120	120	120
3418	OUTPUT 3 DSP FORM	5	5	5	5	5
3419	OUTPUT3 UNIT	11 = mA	11 = mA	11 = mA	11 = mA	11 = mA
3420	OUTPUT3 MIN	0 mA	0 mA	0 mA	0 mA	0 mA
3421	OUTPUT3 MAX	20.0 mA	20.0 mA	20.0 mA	20.0 mA	20.0 mA
3601	TIMERS ENABLE	0 = NOT SEL	0 = NOT SEL	0 = NOT SEL	0 = NOT SEL	0 = NOT SEL
3622	BOOST SEL	0 = NOT SEL	0 = NOT SEL	0 = NOT SEL	0 = NOT SEL	0 = NOT SEL
3626	TIMER 1 SRC	0 = NOT SEL	0 = NOT SEL	0 = NOT SEL	0 = NOT SEL	0 = NOT SEL
4001	GAIN	2.5	2.5	2.5	2.5	2.5
4002	INTEGRATION TIME	3.0	3.0	3.0	3.0	3.0
4005	ERROR VALUE INV	0 = NO	0 = NO	0 = NO	1 = YES	1 = YES
4010	SET POINT SEL	0 = KEYPAD	0 = KEYPAD	0 = KEYPAD	0 = KEYPAD	0 = KEYPAD
4011	INTERNAL SETPNT	40.0%	40.0%	40.0%	40.0%	40.0%
4027	PID 1 PARAM SET	0 = SET 1	0 = SET 1	0 = SET 1	0 = SET 1	0 = SET 1
4110	SET POINT SEL	0 = KEYPAD	0 = KEYPAD	0 = KEYPAD	0 = KEYPAD	0 = KEYPAD
4111	INTERNAL SETPNT	40.0%	40.0%	40.0%	40.0%	40.0%
5302	EFB STATION ID	1	1	1	1	1
5303	EFB BAUD RATE	9.6kbits/s	9.6kbits/s	9.6kbits/s	9.6kbits/s	9.6kbits/s
5304	EFB PARITY	0 = 8NONE1	0 = 8NONE1	0 = 8NONE1	0 = 8NONE1	0 = 8NONE1
5305	EFB CTRL PROFILE	0 = ABB DRV LIM	0 = ABB DRV LIM	0 = ABB DRV LIM	0 = ABB DRV LIM	0 = ABB DRV LIM
8123	PFA ENABLE	0 = NOT SEL	0 = NOT SEL	0 = NOT SEL	0 = NOT SEL	0 = NOT SEL

282 Actual signals and parameters

Index	Name/ Selection	BOOSTER PUMP	PUMP ALTERNA	INT TIMER	INTIMERCs	FLOATING PNT
9902	APPLIC MACRO	6 = BOOSTER PUMP	7 = PUMP ALTERNA	8 = INT TIMER	9 = INT TIMER CS	10 = FLOATING PNT
1001	EXT1 COMMANDS	1 = DI1	1 = DI1	11 = TIMER 1	1 = DI1	1 = DI1
1002	EXT2 COMMANDS	1 = DI1	1 = DI1	11 = TIMER 1	0 = NOT SEL	1 = DI1
1102	EXT1/EXT2 SEL	0 = EXT1	0 = EXT1	0 = EXT1	0 = EXT1	0 = EXT1
1103	REF1 SELECT	1 = AI1	1 = AI1	1 = AI1	0 = KEYPAD	30 = DI4U,5D
1106	REF2 SELECT	19 = PID1OUT	19 = PID1OUT	19 = PID1OUT	2 = AI2	19 = PID1OUT
1201	CONST SPEED SEL	3 = DI3	0 = NOT SEL	0 = NOT SEL	15 = TIMER 1	3 = DI3
1401	RELAY OUTPUT 1	1 = READY	31 = PFA	7 = STARTED	7 = STARTED	7 = STARTED
1601	RUN ENABLE	0 = NOT SEL	0 = NOT SEL	2 = DI2	2 = DI2	2 = DI2
1604	FAULT RESET SEL	0 = KEYPAD	0 = KEYPAD	0 = KEYPAD	0 = KEYPAD	0 = KEYPAD
1608	START ENABLE 1	4 = DI4	0 = NOT SEL	4 = DI4	4 = DI4	4 = DI4
1609	START ENABLE 2	0 = NOT SEL	0 = NOT SEL	5 = DI5	5 = DI5	0 = NOT SEL
2007	MINIMUM FREQ	0.0 Hz	0.0 Hz	0.0 Hz	0.0 Hz	0.0 Hz
2101	START FUNCTION	1 = AUTO	1 = AUTO	6 = SCAN START	6 = SCAN START	6 = SCAN START
2108	START INHIBIT	0 = OFF	0 = OFF	0 = OFF	0 = OFF	0 = OFF
2202	ACCELER TIME 1	10.0 s	10.0 s	30.0 s	30.0 s	30.0 s
2203	DECELER TIME 1	10.0 s	10.0 s	30.0 s	30.0 s	30.0 s
3018	COMM FAULT FUNC	0 = NOT SEL	0 = NOT SEL	0 = NOT SEL	0 = NOT SEL	0 = NOT SEL
3415	SIGNAL3 PARAM	120	120	120	105	105
3418	OUTPUT 3 DSP FORM	5	5	5	1	1
3419	OUTPUT3 UNIT	11 = mA	11 = mA	11 = mA	4 = %	4 = %
3420	OUTPUT3 MIN	0 mA	0 mA	0 mA	-200.0 %	-200.0%
3421	OUTPUT3 MAX	20.0 mA	20.0 mA	20.0 mA	200.0 %	200.0%
3601	TIMERS ENABLE	0 = NOT SEL	0 = NOT SEL	1 = DI1	1 = DI1	0 = NOT SEL
3622	BOOST SEL	0 = NOT SEL	0 = NOT SEL	3 = DI3	3 = DI3	0 = NOT SEL
3626	TIMER 1 SRC	0 = NOT SEL	0 = NOT SEL	31 = P1+2+3+4+B	31 = P1+2+3+4+B	0 = NOT SEL
4001	GAIN	2.5	2.5	2.5	1.0	2.5
4002	INTEGRATION TIME	3.0	3.0	3.0	60.0	3.0
4005	ERROR VALUE INV	0 = NO	0 = NO	0 = NO	0 = NO	0 = NO
4010	SET POINT SEL	0 = KEYPAD	0 = KEYPAD	0 = KEYPAD	1 = AI1	0 = KEYPAD
4011	INTERNAL SETPNT	40.0%	40.0%	40.0%	40.0%	40.0%
4027	PID 1 PARAM SET	0 = SET 1	0 = SET 1	0 = SET 1	0 = SET 1	0 = SET 1
4110	SET POINT SEL	0 = KEYPAD	0 = KEYPAD	0 = KEYPAD	0 = KEYPAD	0 = KEYPAD
4111	INTERNAL SETPNT	40.0%	40.0%	40.0%	40.0%	40.0%
5302	EFB STATION ID	1	1	1	1	1
5303	EFB BAUD RATE	9.6kbits/s	9.6kbits/s	9.6kbits/s	9.6kbits/s	9.6kbits/s
5304	EFB PARITY	0 = 8NONE1	0 = 8NONE1	0 = 8NONE1	0 = 8NONE1	0 = 8NONE1
5305	EFB CTRL PROFILE	0 = ABB DRV LIM	0 = ABB DRV LIM	0 = ABB DRV LIM	0 = ABB DRV LIM	0 = ABB DRV LIM
8123	PFA ENABLE	0 = NOT SEL	1 = ACTIVE	0 = NOT SEL	0 = NOT SEL	0 = NOT SEL

12

Fieldbus control

Contents of this chapter

The chapter describes how the drive can be controlled by external devices over a communication network using embedded fieldbus.

System overview

The drive can be connected to an external control system via embedded fieldbus. The embedded fieldbus supports Modbus RTU, BACnet[®], Metasys[®] N2 and APOGEE[®] FLN protocols.

Embedded fieldbus connection is either RS-232 (control panel connector X2) or EIA-485 (I/O terminals 23...26). The maximum length of the communication cable with RS-232 is restricted to 3 meters.

- RS-232 is designed for a point-to-point application (a single master controlling one slave).
 - EIA-485 is designed for a multipoint application (a single master controlling one or more slaves).
-

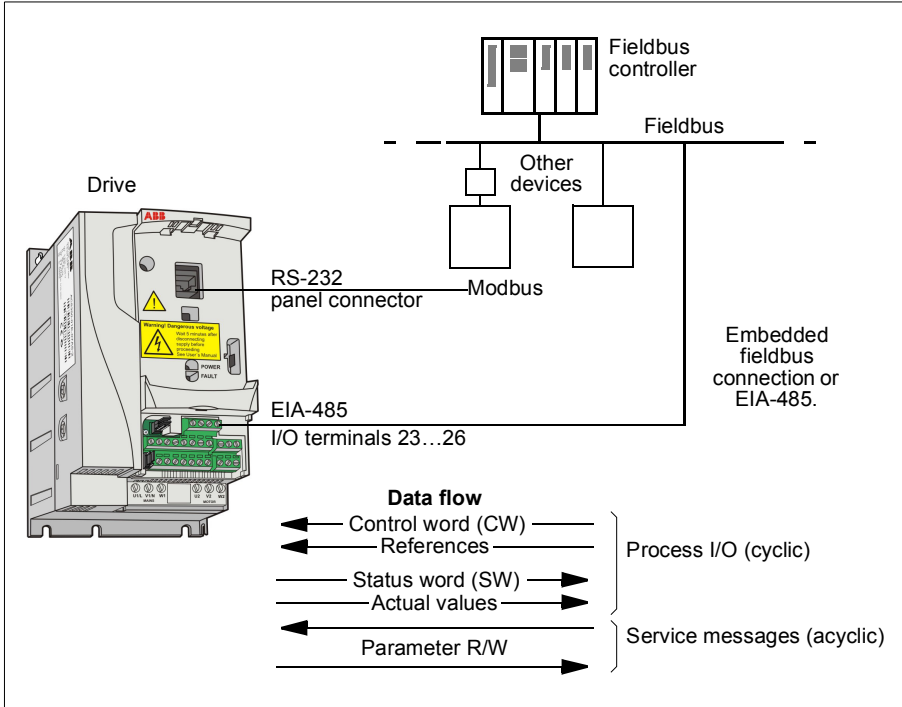

The drive can be set to receive all of its control information through the fieldbus interface, or the control can be distributed between the fieldbus interface and other available sources, for example, digital and analog inputs.

■ Control interface

In general, the basic control interface between the fieldbus system and the drive consists of:

Protocol	Control Interface	Reference for more information
Modbus	<ul style="list-style-type: none"> • Output Words <ul style="list-style-type: none"> – Control word – Reference1 – Reference2 • Input Words <ul style="list-style-type: none"> – Status word – Actual value 1 – Actual value 2 – Actual value 3 – Actual value 4 – Actual value 5 – Actual value 6 – Actual value 7 – Actual value 8 	The content of these words is defined by profiles. For details on the profiles used, see Modbus protocol technical data on page 338.
N2	<ul style="list-style-type: none"> • Binary output objects • Analog output objects • Binary input objects • Analog input objects 	N2 protocol technical data
FLN	<ul style="list-style-type: none"> • Binary output points • Analog output points • Binary input points • Analog input points 	FLN protocol technical data
BACnet	<ul style="list-style-type: none"> • Device management • Binary output objects • Analog output objects • Binary input objects • Analog input objects 	BACnet protocol technical data

Note: The words “output” and “input” are used as seen from the fieldbus controller point of view. For example an output describes data flow from the fieldbus controller to the drive and appears as an input from the drive point of view.

Planning

Network planning should address the following questions:

- What types and quantities of devices must be connected to the network?
- What control information must be sent down to the drives?
- What feedback information must be sent from the drives to the controlling system?

Mechanical and electrical installation – EFB



WARNING! Connections should be made only while the drive is disconnected from the power source.

Drive terminals 23...26 are for EIA-485 communications.

- Use Belden 9842 or equivalent. Belden 9842 is a dual twisted, shielded pair cable with a wave impedance of 120 Ω .
- Use one of these twisted shielded pairs for the EIA-485 link. Use this pair to connect all A (-) terminals together and all B (+) terminals together.
- Use one of the wires in the other pair for the logical ground (terminal 26), leaving one wire unused.
- Do not directly ground the EIA-485 network at any point. Ground all devices on the network using their corresponding grounding terminals.
- As always, the grounding wires should not form any closed loops, and all the devices should be grounded to a common ground.
- Connect the EIA-485 link in a daisy-chained bus, without dropout lines.
- To reduce noise on the network, terminate the EIA-485 network using 120 Ω resistors at both ends of the network. Use jumper J701 to connect or disconnect the termination resistors. See below wiring diagram. This circuit provides pull-up active termination resistors.
- For configuration information see the following:
 - below.
 - [Activate drive control functions – EFB](#) on page 294.
 - The appropriate EFB protocol specific technical data. For example, [Modbus protocol technical data](#) on page 338.

Preferred Wiring Diagram

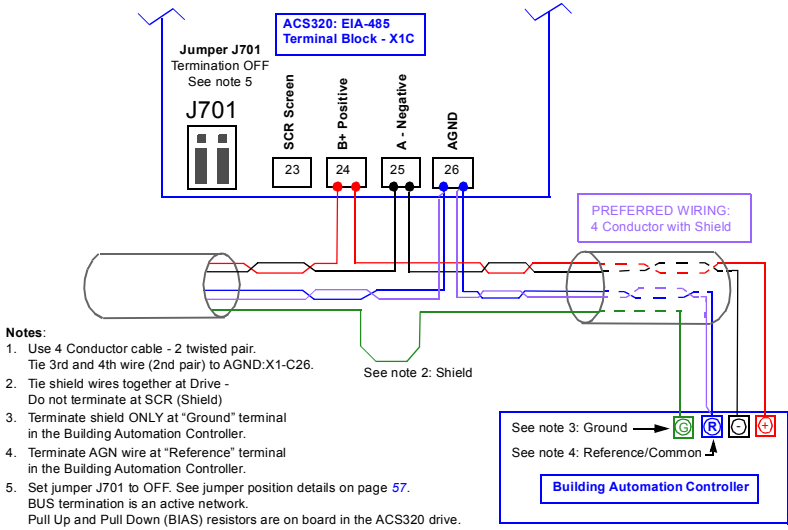

Alternate Wiring Diagram

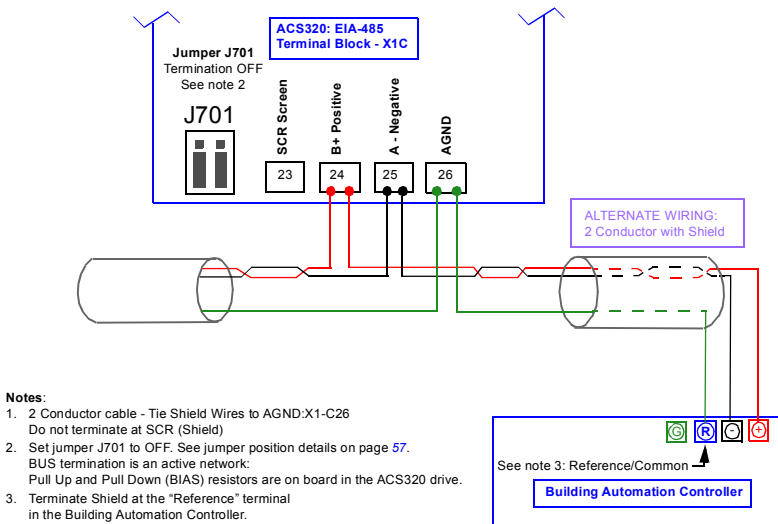

Communication set-up – EFB

■ Serial communication selection

To activate the serial communication, set parameter *9802 COMM PROT SEL* =

- 1 (STD MODBUS)
- 2 (N2)
- 3 (FLN)
- 5 (BACNET).

Note: If you cannot see the desired selection on the panel, your drive does not have that protocol software in the application memory.

■ Serial communication configuration

Setting parameter *9802 COMM PROT SEL* automatically sets the appropriate default values in parameters that define the communication process. These parameters and descriptions are defined below. In particular, note that the station Id may require adjustment.

Code	Description	EFB Protocol Reference			
		Modbus	N2	FLN	BACnet
5301	<i>EFB PROTOCOL ID</i> Contains the identification and program revision of the protocol.	Do not edit. Any non-zero value entered for parameter <i>9802 COMM PROT SEL</i> , sets this parameter automatically. The format is: XXYY, where xx = protocol ID, and YY = program revision.			
5302	<i>EFB STATION ID</i> Defines the node address of the EIA-485 link.	Set each drive on the network with a unique value for this parameter. When this protocol is selected, the default value for this parameter is: 1 Note: For a new address to take affect, the drive power must be cycled OR 5302 must first be set to 0 before selecting a new address. Leaving 5302 = 0 places the EIA-485 channel in reset, disabling communication.		Sets MS/TP MAC ID. A temporary value of 0 places the protocol channel in reset.	

Code	Description	EFB Protocol Reference			
		Modbus	N2	FLN	BACnet
5303	EFB BAUD RATE Defines the communication speed of the EIA-485 link in kbits per second (kbits/s). 1.2 kbits/s 2.4 kbits/s 4.8 kbits/s 9.6 kbits/s 19.2 kbits/s 38.4 kbits/s 57.6 kbits/s 76.8 kbits/s	When this protocol is selected, the default value for this parameter is			When this protocol is selected, the default value for this parameter is: 38400.
		9.6	9.6	4.8	
5304	EFB PARITY Defines the data length, parity and stop bits to be used with the EIA-485 link communication. The same settings must be used in all on-line stations. 0 = 8N1 – 8 data bits, No parity, one stop bit. 1 = 8N2 – 8 data bits, No parity, two stop bits. 2 = 8E1 – 8 data bits, Even parity, one stop bit. 3 = 8O1 – 8 data bits, Odd parity, one stop bit.	When this protocol is selected, the default value for this parameter is: 1	When this protocol is selected, the default value for this parameter is: 0		
				Sets MS/TP character format.	

Code	Description	EFB Protocol Reference			
		Modbus	N2	FLN	BACnet
5305	<p>EFB CTRL PROFILE</p> <p>Selects the communication profile used by the EFB protocol.</p> <p>0 = ABB DRV LIM – Operation of Control/Status Words conform to ABB Drives Profile, as used in ACH400.</p> <p>1 = DCU PROFILE – Operation of Control/Status Words conform to 32-bit DCU Profile.</p> <p>2 = ABB DRV FULL – Operation of Control/Status Words conform to ABB Drives Profile, as used in ACH600/800.</p>	When this protocol is selected, the default value for this parameter is: 0	N/A. When this protocol is selected, the default value for this parameter is: 0. Changing the value for this parameter has no affect on this protocol's behavior.		
5310	EFB PAR10	Not used for Comm setup.	Sets them response turnaround time in milliseconds. When this protocol is selected, the default value is: 3 msec. 0 msec. 5 msec.		
5311	EFB PAR11	Not used for Comm setup.	<p>This parameter, together with parameter 5317, sets BACnet Device Object Instance IDs:</p> <p>For the range 1 to 65,535: This parameter sets the ID directly (5317 must be 0). For example, the following values set the ID to 49134: 5311 = 49134 and 5317 = 0.</p> <p>For IDs > 65,335: The ID equals 5311's value plus 10,000 times 5317's value. For example, the following values set the ID to 71234: 5311 = 1234 and 5317 = 7.</p>		
5312	EFB PAR12	Not used for Comm setup.	This parameter sets the BACnet Device Object Max Info Frames Property.		

Code	Description	EFB Protocol Reference			
		Modbus	N2	FLN	BACnet
5313	EFB PAR13	Not used for Comm setup.			This parameter sets the BACnet Device Object Max Master Property.
5314	EFB PAR14	Not used for Comm setup.			
5315	EFB PAR15	Not used for Comm setup.			
5316	EFB PAR 16	Not used for Comm setup.			This parameter indicates the count of MS/TP tokens passed to this drive.
5317	EFB PAR17				This parameter works with parameter 5311 to set BACnet Device Object Instance IDs. See parameter 5311.

Note: After any changes to the communication settings, protocol must be reactivated by either cycling the drive power, or by clearing and then restoring the station Id (5302) or use Reinitialize Device Service.

Activate drive control functions – EFB

■ Controlling the drive

Fieldbus control of various drive functions requires configuration to:

- Tell the drive to accept fieldbus control of the function.
- Define as a fieldbus input, any drive data required for control.
- Define as a fieldbus output, any control data required by the drive.

The following sections describe, at a general level, the configuration required for each control function. For the protocol-specific details, see the document supplied with the FBA module.

■ Start/Stop direction control

Using the fieldbus for start/stop/direction control of the drive requires:

- Drive parameter values set as defined below.
- Fieldbus controller supplied command(s) in the appropriate location. (The location is defined by the Protocol Reference, which is protocol dependent.)

Drive Parameter		Value	Description	Protocol Reference				
				Modbus ¹		N2	FLN	BACnet
				abb drv	dcu profile			
1001	EXT1 COMMANDS	10 (COMM)	Start/Stop by fieldbus with Ext1 selected.	40001 bits 0...3	40031 bits 0, 1	BO1	24	BV10
1002	EXT2 COMMANDS	10 (COMM)	Start/Stop by fieldbus with Ext2 selected.	40001 bits 0...3	40031 bits 0, 1	BO1	24	BV10
1003	DIRECTION	3 (REQUEST)	Direction by fieldbus.	40002/ 40003 ²	40031 bit 2	BO2	22	BV11

1. For Modbus, the protocol reference can depend on the profile used, hence two columns in these tables. One column refers to the ABB Drives profile, selected when parameter **5305** = 0 (ABB DRV LIM) or **5305** = 2 (ABB DRV FULL). The other column refers to the DCU profile selected when parameter **5305** = 1 (DCU PROFILE). See section [ABB control profiles technical data](#).

2. The reference provides direction control – a negative reference provides reverse rotation.

Input reference select

Using the fieldbus to provide input references to the drive requires:

- Drive parameter values set as defined below.
- Fieldbus controller supplied reference word(s) in the appropriate location. (The location is defined by the Protocol Reference, which is protocol dependent.)

Drive Parameter		Value	Setting	Protocol Reference				
				Modbus		N2	FLN	BACnet
				abb drv	dcu profile			
1102	EXT1/ EXT2 SEL	8 (COMM)	Reference set selection by fieldbus.	40001 bit 11	40031 bit 5	BO5	26	BV13
1103	REF1 SEL	8 (COMM)	Input reference 1 by fieldbus.	40002		AO1	60	AV16
1106	REF2 SEL	8 (COMM)	Input reference 2 by fieldbus.	40003		AO2	61	AV17

Reference scaling

Where required, REFERENCES can be scaled. See the following, as appropriate:

- Modbus Register [40002](#) in the [Modbus protocol technical data](#) section.
- [Reference scaling](#) in the [ABB control profiles technical data](#) section.
- [N2 analog output objects](#) in the [N2 protocol technical data](#) section.
- The slope of points 60 and 61 in the [FLN protocol technical data](#) section.

■ Miscellaneous drive control

Note: The user should change only the parameters for the functions you wish to control via fieldbus. All other parameters should typically remain at factory default. For simple start/stop and speed reference fieldbus control, only parameters **1001 EXT1 COMMANDS** and **1103 REF1 SELECT** need to be changed to COMM.

Using the fieldbus for miscellaneous drive control requires:

- Drive parameter values set as defined below.
- Fieldbus controller supplied reference word(s) in the appropriate location. (The location is defined by the Protocol Reference, which is protocol dependent.)

Drive Parameter		Value	Setting	Protocol Reference				
				Modbus		N2	FLN	BACnet
				abb drv	dcu profile			
1601	RUN ENABLE	7 (COMM)	Run enable by fieldbus. (Not recommended ¹)	40001 bit 3	40031 bit 6 (inverted)	BO4	35	BV12
1604	FAULT RESET SEL	8 (COMM)	Fault reset by fieldbus.	40001 bit 7	40031 bit 4	BO6	94	BV14
1606	LOCAL LOCK	8 (COMM)	Source for local lock selection is the fieldbus.	Does not apply	40031 bit 14			
1607	PARAM SAVE	1 (SAVE)	Saves altered parameters to memory (then value returns to 0).	41607	41607	BO18	N/A ¹	
1608	START ENABLE 1	7 (COMM)	Source for start enable 1 is the fieldbus Command word. (Not recommended) ¹	Does not apply.	40032 bit 2			BV20
1609	START ENABLE 2	7 (COMM)	Source for start enable 2 is the fieldbus Command word. (Not recommended) ¹		40032 bit 3			BV21
2201	ACC/DEC 1/2 SEL	7 (COMM)	Source for ramp pair selection is the fieldbus.		40031 bit 10			

1.ABB recommends hard wiring run permissive and safeties.

■ Relay output control

Using the fieldbus for relay output control requires:

- Drive parameter values set as defined below.
- Fieldbus controller supplied reference word(s) in the appropriate location. (The location is defined by the Protocol Reference, which is protocol dependent.)

Drive Parameter		Value	Setting	Protocol Reference				
				Modbus		N2	FLN	BACnet
				abb drv	dcu profile			
1401	RELAY OUTPUT 1	35 (COMM)	Relay Output 1 controlled by fieldbus.	40134 bit 0 or 00033	B07	40	B00	
1402 ¹	RELAY OUTPUT 2	35 (COMM)	Relay Output 2 controlled by fieldbus.	40134 bit 2 or 00034	B08	41	B01	
1403 ¹	RELAY OUTPUT 3	35 (COMM)	Relay Output 3 controlled by fieldbus.	40134 bit 3 or 00035	B09	42	B02	
1410 ¹	RELAY OUTPUT 4	35 (COMM)	Relay Output 4 controlled by fieldbus.	40134 bit 4 or 00036	B010	43	B03	

1. More than 1 relay requires the addition of a relay extension module.

For example: To control relays 1 and 2 using serial communication:

Set parameters *1401 RELAY OUTPUT 1* and *1402 RELAY OUTPUT 2* = 35 (COMM).

Then, for example using N2:

- To turn Relay 1 On: Force object B07 to On.
- To turn Relay 2 On: Force object B08 to On.
- To turn both Relay 1 and 2 On: Force objects B07 and B08 On.

Note: Relay status feedback occurs without configuration as defined below.

Drive Parameter		Value	Setting	Protocol Reference				
				Modbus		N2	FLN	BACnet
				abb drv	dcu profile			
0162	RO STATUS	Relay status.	40122	0122	B14... B16	76... 78	B10... B12	
0173	RO 2-4 STATUS	Relay 2-4 status.	40123	0123	B17	79	B13	

■ Analog output control

Using the fieldbus for analog output control requires:

- Drive parameter values set as defined below.
- Fieldbus controller supplied reference word(s) in the appropriate location. (The location is defined by the Protocol Reference, which is protocol dependent.)

Drive Parameter		Value	Setting	Protocol Reference				
				Modbus		N2	FLN	BACnet
				abb drv	dcu profile			
1501	AO1 CONTENT SEL	135 (COMM VALUE 1)	Analog Output 1 controlled by writing to parameter 0135.	–	–	–	–	
0135	COMM VALUE 1	–		40135	AO14	46	AO0	

■ PID control setpoint source

Use the following settings to select the fieldbus as the setpoint source for PID loops:

Drive Parameter		Value	Setting	Protocol Reference				
				Modbus		N2	FLN	BACnet
				abb drv	dcu profile			
4010	SET POINT SEL (Set 1)	8 (COMM VALUE 1) 9 (COMM + A11) 10 (COMM*A11)	Setpoint is either: Input Reference 2 (+/-/* A11). Control requires parameter 1106 value = comm. Process PID setpoint. Control requires parameter 1106 value = pid1 out and parameter 4010 value = comm.	40003	AO2	61	AV17	
4110	SET POINT SEL (Set 2)							
4210	SET POINT SEL (Ext/Trim)							

■ Communication fault

When using fieldbus control, specify the drive's action if serial communication is lost.

Drive Parameter	Value	Description
3018	COMM FAULT FUNC	0 (NOT SEL)) 1 (FAULT) 2 (CONST SP7) 3 (LAST SPEED)
3019	COMM FAULT TIME	Set time delay before acting on a communication loss.

Feedback from the drive – EFB

■ Pre-defined feedback

Inputs to the controller (drive outputs) have pre-defined meanings established by the protocol. This feedback does not require drive configuration. The following table lists a sample of feedback data. For a complete listing, see input word/point/object listings in the technical data for the appropriate protocol starting on [304](#).

Drive Parameter		Protocol Reference			
		Modbus	N2	FLN	BACnet
0102	SPEED	40102	AI3	5	AV0
0103	FREQ OUTPUT	40103	AI1	2	AV1
0104	CURRENT	40104	AI4	6	AV4
0105	TORQUE	40105	AI5	7	AV5
0106	POWER	40106	AI6	8	AV6
0107	DC BUS VOLT	40107	AI11	13	AV2
0109	OUTPUT VOLTAGE	40109	AI12	14	AV3
0115	KWH COUNTER	40115	AI8	10	AV8

Note: With Modbus, any parameter can be accessed using the format: 4 followed by the parameter number.

■ Mailbox Read/Write

The ACS320 provides a “Mailbox” function to access parameters that have not been pre-defined by the protocol. Using mailbox, any drive parameter can be identified and read. Mailbox can also be used to adjust parameter settings by writing a value to any parameter identified. The following table describes the use of this function.

Name	Description	Protocol Reference			
		Modbus ¹	N2	FLN	BACnet
Mailbox Parameter	Enter the number of the drive parameter to access.	Does not apply.	AO19	95	AV25
Mailbox Data	Contains the parameter value after a read, or enter the desired parameter value for a write.		AO20	96	AV26
Mailbox Read	A binary value triggers a read – the value of the “Mailbox Parameter” appears in “Mailbox data”.		BO19	97	BV15
Mailbox Write	A binary value triggers a write – the drive value for the “Mailbox Parameter” changes to the value in “Mailbox data”.		BO20	98	BV16

¹As noted above, Modbus provides direct access to all parameters using the format: 4 followed by the parameter number.

■ Actual value scaling

The scaling of actual values can be protocol dependent. In general, for Actual values, scale the feedback integer using the parameter's resolution. (See section [Parameter listing](#) for parameter resolutions.) For example:

Feedback Integer	Parameter Resolution	(Feedback Integer) * (Parameter Resolution) = Scaled Value
1	0.1 mA	1 * 0.1 mA = 0.1 mA
10	0.1%	10 * 0.1% = 1%

Where parameters are in percent, section [Parameter listing](#) specifies what parameter corresponds to 100%. In such cases, to convert from percent to engineering units, multiply by the value of the parameter that defines 100% and divide by 100%. For example:

Feedback Integer	Parameter Resolution	Value of the Parameter that defines 100%	(Feedback Integer) * (Parameter Resolution) * (Value of 100% Ref.) / 100% = Scaled Value
10	0.1%	1800 rpm ¹	10 * 0.1% * 1800 RPM / 100% = 18 rpm
100	0.1%	600 Hz ²	100 * 0.1% * 600 Hz / 100% = 60 Hz

1. Assuming, for the sake of this example, that the Actual value uses parameter [9908 MOTOR NOM SPEED](#) as the 100% reference, and that 9908 = 1800 rpm.

2. Assuming, for the sake of this example, that the Actual value uses parameter [9907 MOTOR NOM FREQ](#) as the 100% reference, and that 9907 = 6.00 Hz.

Although Actual value scaling could differ from the above for the N2 and FLN protocols, it currently does not. To confirm, see the following sections, as appropriate:

- [N2 analog input objects](#) in the [N2 protocol technical data](#) section.
- [Scaling drive feedback values](#) in the [FLN protocol technical data](#) section.

Scaling does not apply for the BACnet protocol.

Diagnostics – EFB

Fault queue for drive diagnostics

For general ACS320 diagnostics information, see section [LEDs](#). The three most recent ACS320 faults are reported to the fieldbus as defined below.

Drive Parameter		Protocol Reference			
		Modbus	N2	FLN	BACnet
0401	Last Fault	40401	17	90	AV18
0412	Previous Fault 1	40402	18	91	AV19
0413	Previous Fault 2	40403	19	92	AV20

Serial communication diagnostics

Network problems can be caused by multiple sources. Some of these sources are:

- Loose connections
- Incorrect wiring (including swapped wires)
- Bad grounding
- Duplicate station numbers
- Incorrect setup of drives or other devices on the network

The major diagnostic features for fault tracing on an EFB network include [Group 53: EFB protocol](#) parameters [5306...5309](#). Section [Parameter listing](#) describes these parameters in detail.

Diagnostic situations

The sub-sections below describe various diagnostic situations – the problem symptoms and corrective actions.

Normal operation

During normal network operation, [5306...5309](#) parameter values act as follows at each drive:

- [5306 EFB OK MESSAGES](#) advances (advances for each application message properly received and addressed to this drive).
- [5307 EFB CRC ERRORS](#) does not advance at all (advances when an invalid message CRC is received).
- [5308 EFB UART ERRORS](#) does not advance at all (advances when character format errors are detected, such as parity or framing errors).
- [5309 EFB STATUS](#) value varies depending on network traffic.
- BACnet protocol: 5316 EFB PAR 16 (MS/TP token counter) advances for each token passed to this drive. (Does not apply for other protocols.)

Loss of communication

The AC320 behavior, if communication is lost, was configured in *Communication fault*. The parameters are *3018 COMM FAULT FUNC* and *3019 COMM FAULT TIME*. Section *Parameter listing* describes these parameter.

No master station on line

If no master station is on line: Neither the *EFB OK MESSAGES* nor the errors (*5307 EFB CRC ERRORS* and *5308 EFB UART ERRORS*) increase on any of the stations.

To correct:

- Check that a network master is connected and properly programmed on the network.
- Verify that the cable is connected, and is not cut or short circuited.

Duplicate stations

If two or more stations have duplicate numbers:

- Two or more drives cannot be addressed.
- Every time there is a read or write to one particular station, the value for *5307 EFB CRC ERRORS* or *5308 EFB UART ERRORS* advances.

To correct: Check all station numbers and edit conflicting values.

Swapped wires

If the communication wires are swapped (terminal A on one drive is connected to terminal B on another):

- The value of *5306 EFB OK MESSAGES* does not advance.
- The values of *5307 EFB CRC ERRORS* and *5308 EFB UART ERRORS* are advancing.

To correct: Check that the EIA-485 lines are not swapped.

Fault 28 – Serial 1 Err

If the drive's control panel shows fault *0028 SERIAL 1 ERR*, check for either of the following:

- The master system is down. To correct, resolve problem with master system.
 - The communication connection is bad. To correct, check communication connection at the drive.
 - The time-out selection for the drive is too short for the given installation. The master is not polling the drive within the specified time-out delay. To correct, increase the time set by parameter *3019 COMM FAULT TIME*.
-

Fault 31 – EFB1

For BACnet: If the drive's control panel shows fault *0031 EFB 1*, the drive has an invalid Device Object Instance ID. To correct, use parameters 5311 and 5317 and establish a unique drive ID that is in the range 1 to 4,194,303.

Faults 31...33 – EFB1...EFB3

Except as noted above, these three EFB fault codes (*0031 EFB 1...0033 EFB 3*) are not used.

Intermittent off-line occurrences

The problems described above are the most common problems encountered with ACS320 serial communication. Intermittent problems might also be caused by:

- Marginally loose connections,
 - Wear on wires caused by equipment vibrations,
 - Insufficient grounding and shielding on both the devices and on the communication cables.
-

N2 protocol technical data

■ Overview

The N2 fieldbus connection to the ACS320 drives is based on an industry standard RS-485 physical interface. The N2 fieldbus protocol is a master-slave type, serial communication protocol, used by the Johnson Controls Metasys® system. In the Metasys architecture the N2 fieldbus connects object interfaces and remote controllers to Network Control Units (NCUs).

The N2 fieldbus can also be used to connect ACS320 drives to the Metasys Companion product line.

This section describes the use of the N2 fieldbus with the ACS320 drives' connection and does not describe the protocol in detail.

Supported features

In the N2 fieldbus protocol the ACS320 drive appears as a “virtual object”.

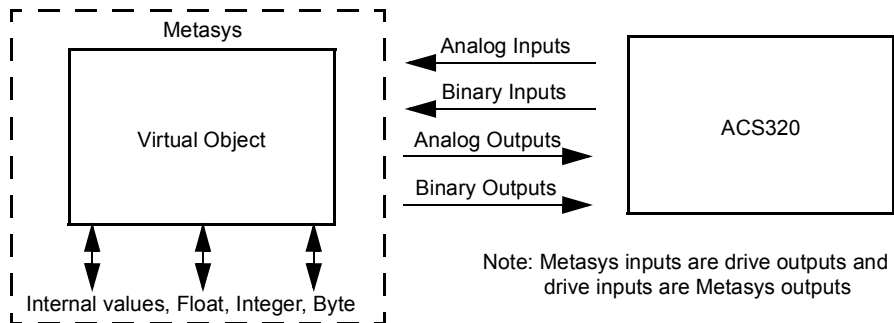

A virtual object is made up of:

- Analog Inputs
- Binary Inputs
- Analog Outputs
- Binary Outputs
- Internal values for Floating point, Integer, and Byte values.

The ACS320 drive does not support N2 fieldbus communication “internal values”.

All of the Analog and Binary I/O objects are listed below, starting with [N2 analog input objects](#) below.

Analog input – The analog input objects support the following features:

- Analog Input actual value in engineering units
- Low Alarm limit
- Low Warning limit
- High Warning limit
- High Alarm limit
- Differential value for the hysteresis of the Alarms and Warnings
- Change of State (COS) enabled
- Alarm Enabled
- Warning Enabled
- Override value is received, but there is no action taken.

Binary input – The binary input objects support the following features:

- Binary Input actual value
- Normal / Alarm state specification
- Alarm Enabled
- Change of State (COS) enabled
- Override value is received, but there is no action taken.

Analog output – The analog output objects support the following features:

- Analog Output value in engineering units
- Override value is used to change the Analog Output value. It is not possible to return to the previous value by removing the override. The override feature is used only to change the value.

Binary output – The binary output objects support the following features:

- Binary Output value
 - Override value is used to change the Binary Output value. It is not possible to return to the previous value by removing the override. The override feature is used only to change the value.
-

Metasys integration

The following diagram shows the drives' integration to the Johnson Controls Metasys system.

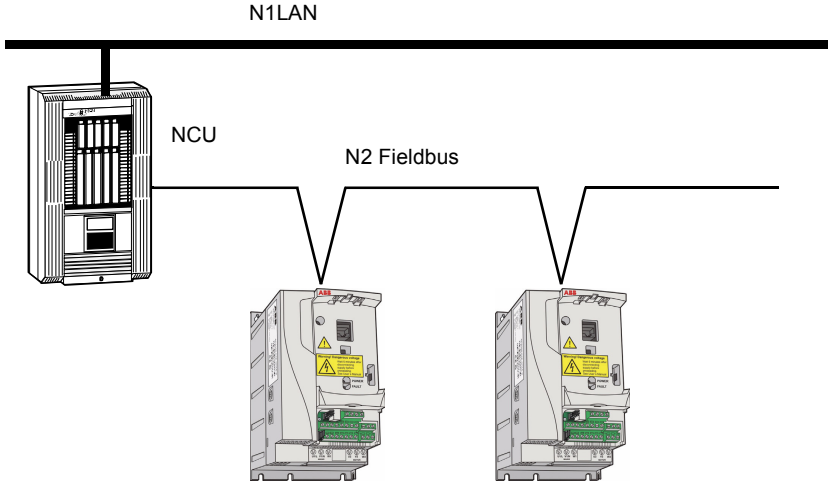

The following diagram shows the drives' integration to the Johnson Controls Metasys Companion system.

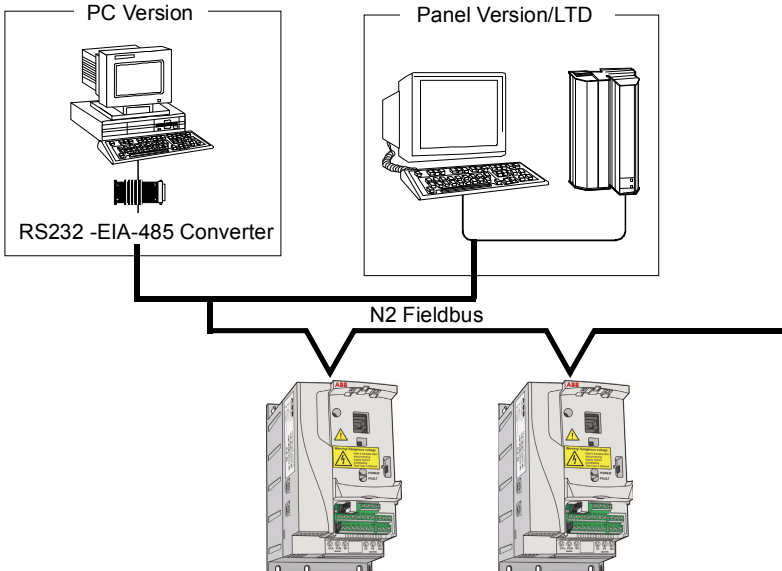

On the N2 fieldbus each ACS320 drive can be accessed by the full complement of Metasys FMS features, including Change-of-State (COS) monitoring, alarm notification, scheduling, trend, and totalization.

On one N2 fieldbus segment there can be up to 32 nodes while integrating ACS320 drives with Johnson Controls Metasys.

Drive device type

For the Metasys and Metasys Companion products, the device type for the ACS320 drive is VND.

■ N2 analog input objects

The following table lists the N2 analog Input objects defined for the ACS320 drive.

N2 Analog Inputs:					
Number	Object	Drive Parameter	Scale Factor	Units	Range
AI1	OUTPUT FREQUENCY	0103	10	Hz	0...250
AI2	RATED SPEED	Note 1	10	%	0 ...100
AI3	SPEED	0102	1	rpm	0 ...9999
AI4	CURRENT	0104	10	A	0...9999
AI5	TORQUE	0105	10	%	-200...200
AI6	POWER	0106	10	kW	0...9999
AI7	DRIVE TEMPERATURE	0110	10	°C	0 ...125
AI8	KILOWATT HOURS	0115	1	kWh	0...65535
AI9	MEGAWATT HOURS	0141	1	MWh	0...65535
AI10	RUN TIME	0114	1	H	0...65535
AI11	DC BUS VOLTAGE	0107	1	V	0...999
AI12	OUTPUT VOLTAGE	0109	1	V	0...999
AI13	PRC PID FEEDBACK	0130	10	%	0...100
AI14	PRC PID DEVIATION	0132	10	%	0...100
AI15	EXT PID FEEDBACK	0131	10	%	0...100
AI16	EXT PID DEVIATION	0133	10	%	0...100
AI17	LAST FAULT	0401	1		fault code
AI18	PREV FAULT	0402	1		fault code
AI19	OLDEST FAULT	0403	1		fault code
AI20	AI 1 ACTUAL	0120	10	%	0...100
AI21	AI 2 ACTUAL	0121	10	%	0...100
AI22	AO 1 ACTUAL	0124	10	mA	0...20
AI24	MOTOR TEMP	0145	1	°C	0...200
AI25	REVOLUTION CNT	0142	1	MREV	0...32767

1.RATED SPEED is a percent of maximum frequency (parameter 2008) if the drive is in scalar mode, and is a percent of maximum speed (parameter 2002) in speed mode.

■ N2 binary input objects

The following table lists the N2 binary input objects defined for the ACS320 drive.

N2 Binary Inputs:			
Number	Object	Drive Parameter	Range
BI1	STOP/RUN	Status Word	0 = Stop, 1 = Drive Running
BI2	FORWARD/REVERSE	Status Word	0 = Forward, 1 = Reverse
BI3	FAULT STATUS	Status Word	0 = OK, 1 = Drive Fault
BI16	EXTERNAL 2 SELECT	Status Word	0 = EXT1 = EXT2
BI17	HAND/AUTO	Status Word	0 = AUTO, 1 = HAND
BI18	ALARM	Status Word	0 = OK, 1 = ALARM
BI19	MAINTENANCE REQ	Status Word	0 = OK, 1 = MAINT REQ
BI20	DRIVE READY	Status Word	0 = Not Ready, 1 = Ready
BI21	AT SETPOINT	Status Word	0 = No, 1 = At Setpoint
BI22	RUN ENABLED	Status Word	0 = Not Enabled, 1 = Enabled
BI23	N2 LOCAL MODE	Status Word	0 = Auto, 1 = N2 Local
BI24	N2 CONTROL SRC	Status Word	0 = No, 1 = Yes
BI25	N2 REF1 SRC	Status Word	0 = No, 1 = Yes
BI26	N2 REF2 SRC	Status Word	0 = No, 1 = Yes

1. Require optional MREL relay output card.

■ N2 analog output objects

The following table lists the N2 analog output objects defined for the ACS320 drive.

N2 Analog Outputs:					
Number	Object	Drive Parameter	Scale Factor	Units	Range
AO1	REFERENCE 1	Reference 1	10	%	0...100
AO2	REFERENCE 2	Reference 2	10	%	0...100
AO3	ACCEL TIME 1	2202	10	s	0.1...1800
AO4	DECEL TIME 1	2203	10	s	0.1...1800
AO5	CURRENT LIMIT	2003	10	A	0...1.3*I _{2N}
AO6	PID1-CONT GAIN	4001	10	%	0.1...100
AO7	PID1-CONT I-TIME	4002	10	s	0.1...600
AO8	PID1-CONT D-TIME	4003	10	s	0...10
AO9	PID1-CONT D FILTER	4004	10	s	0...10
AO10	PID2-CONT GAIN	4101	10	%	0.1...100
AO11	PID2-CONT I-TIME	4102	10	s	0.1...600
AO12	PID2-CONT D-TIME	4103	10	s	0...10
AO13	PID2-CONT D FILTER	4104	10	s	0...10

N2 Analog Outputs:					
Number	Object	Drive Parameter	Scale Factor	Units	Range
AO14	COMMAND AO 1	135	10	%	0...100
AO16	EXT PID SETPOINT	4211	10	%	0...100
A019	MAILBOX PARAMETER		1		0...65535
A020	MAILBOX DATA		1		0...65535

■ N2 binary output objects

The following table lists the N2 binary output objects defined for the ACS320 drive.

N2 Binary Outputs:			
Number	Object	Drive Parameter	Range
BO1	STOP/START	Command word	0 = Stop, 1 = Start to Speed
BO2	FORWARD/REVERSE	Command word	0 = Forward, 1 = Reverse
BO3	PANEL LOCK	Command word	0 = Open, 1 = Locked
BO4	RUN ENABLE	Command word	0 = Enable, 1 = Disable
BO5	REF1/REF2 SELECT	Command word	0 = Ref1, 1 = Ref2
BO6	FAULT RESET	Command word	Change 0 -> 1 Resets
BO7	COMMAND RO 1	134 (bit mask 01)	0 = Off, 1 = On
BO8	COMMAND RO 2	134 (bit mask 04)	0 = Off, 1 = On ¹
BO9	COMMAND RO 3	134 (bit mask 08)	0 = Off, 1 = On ¹
BO10	COMMAND RO 4	134 (bit mask 16)	0 = Off, 1 = On ¹
BO13	RESET RUN TIME	114 (indirectly)	0 = N/A, 1 = On (Reset Run Time)
BO14	RESET KWH COUNT	115 (indirectly)	0 = N/A, 1 = On (Reset kWh Count)
BO15	PRC PID SELECT	4027 (indirectly)	0 = SET2, 1 = SET2
BO16	N2 LOCAL CTL ²	Command word	0 = Auto, 1 = N2
BO17	N2 LOCAL REF ²	Command word	0 = Auto, 1 = N2
BO18	SAVE PARAMETERS	1607 (indirectly)	0 = N/A, 1 = On (Save Parameters)
B019	READ MAILBOX		0 = No, 1 = Yes
B020	WRITE MAILBOX		0 = No, 1 = Yes

1.Requires optional MREL relay output card.

2.N2 LOCAL CTL and N2 LOCAL REF have priority over drive input terminals. Use these binary outputs for temporary N2 control of the drive when COMM is not the selected control source.

■ DDL file for NCU

The listing below is the Data Definition Language (DDL) file for ACS320 drives used with the Network Control Units.

This listing is useful when defining drive I/O objects to the Network Controller Units.

Below is the ACS320.DDL file listing.

```
*****
* ABB Drives, ACS 320 Variable Frequency Drive
*****
CSMODEL "ACS_320", "VND"

AITITLE "Analog_Inputs"
BITITLE "Binary_Inputs"
AOTITLE "Analog_Outputs"
BOTITLE "Binary_Outputs"

CSAI "AI1",N,N,"FREQ_ACT","Hz"
CSAI "AI2",N,N,"PCT_ACT","%"
CSAI "AI3",N,N,"SPEED","RPM"
CSAI "AI4",N,N,"CURRENT","A"
CSAI "AI5",N,N,"TORQUE","%"
CSAI "AI6",N,N,"POWER","kW"
CSAI "AI7",N,N,"DRV_TEMP","°C"
CSAI "AI8",N,N,"ENERGY_k","kWh"
CSAI "AI9",N,N,"ENERGY_M","MWh"
CSAI "AI10",N,N,"RUN_TIME","H"
CSAI "AI11",N,N,"DC_VOLT","V"
CSAI "AI12",N,N,"VOLT_ACT","V"
CSAI "AI13",N,N,"PID1_ACT","%"
CSAI "AI14",N,N,"PID2_DEV","%"
CSAI "AI15",N,N,"PID2_ACT","%"
CSAI "AI16",N,N,"PID2_DEV","%"
CSAI "AI17",N,N,"LAST_FLT","Code"
CSAI "AI18",N,N,"PREV_FLT","Code"
CSAI "AI19",N,N,"1ST_FLT","Code"
CSAI "AI20",N,N,"AI_1_ACT","%"
CSAI "AI21",N,N,"AI_2_ACT","%"
CSAI "AI22",N,N,"AO_1_ACT","mA"
CSAI "AI24",N,N,"MTR_TEMP","°C"
CSAI "AI25",N,N,"REVL_CNT",""

CSBI "BI1",N,N,"STOP/RUN","STOP","RUN"
CSBI "BI2",N,N,"FWD/REV","FWD","REV"
CSBI "BI3",N,N,"FAULT","OK","FLT"
CSBI "BI4",N,N,"RELAY_1","OFF","ON"
CSBI "BI5",N,N,"RELAY_2","OFF","ON"
```

```

CSBI "BI6",N,N,"RELAY_3","OFF","ON"
CSBI "BI7",N,N,"RELAY_4","OFF","ON"
CSBI "BI10",N,N,"INPUT_1","OFF","ON"
CSBI "BI11",N,N,"INPUT_2","OFF","ON"
CSBI "BI12",N,N,"INPUT_3","OFF","ON"
CSBI "BI13",N,N,"INPUT_4","OFF","ON"
CSBI "BI14",N,N,"INPUT_5","OFF","ON"
CSBI "BI16",N,N,"EXT1/2","EXT1","EXT2"
CSBI "BI17",N,N,"HND/AUTO","HAND","AUTO"
CSBI "BI18",N,N,"ALARM","OFF","ON"
CSBI "BI19",N,N,"MNTNCE_R","OFF","ON"
CSBI "BI20",N,N,"DRV_REDY","NO","YES"
CSBI "BI21",N,N,"AT_SETPT","NO","YES"
CSBI "BI22",N,N,"RUN_ENAB","NO","YES"
CSBI "BI23",N,N,"N2_LOC_M","AUTO","N2_L"
CSBI "BI24",N,N,"N2_CTRL","NO","YES"
CSBI "BI25",N,N,"N2_R1SRC","NO","YES"
CSBI "BI26",N,N,"N2_R2SRC","NO","YES"
CSAO "AO1",Y,Y,"REF_1","%"
CSAO "AO2",Y,Y,"REF_2","%"
CSAO "AO3",Y,Y,"ACCEL_1","s"
CSAO "AO4",Y,Y,"DECEL_1","s"
CSAO "AO5",Y,Y,"CURR_LIM","A"
CSAO "AO6",Y,Y,"PID1_GN","%"
CSAO "AO7",Y,Y,"PID1_I","s"
CSAO "AO8",Y,Y,"PID1_D","s"
CSAO "AO9",Y,Y,"PID1_FLT","s"
CSAO "AO10",Y,Y,"PID2_GN","%"
CSAO "AO11",Y,Y,"PID2_I","s"
CSAO "AO12",Y,Y,"PID2_D","s"
CSAO "AO13",Y,Y,"PID2_FLT","s"
CSAO "AO14",Y,Y,"CMD_AO_1","%"
CSAO "AO16",Y,Y,"PI2_STPT","%"
CSAO "AO17",Y,Y,"MIN_SPD","%"
CSAO "AO18",Y,Y,"MAX_SPD","%"
CSAO "AO19",Y,Y,"MB_PARAM",""
CSAO "AO20",Y,Y,"MB_DATA",""
CSBO "BO1",Y,Y,"START","STOP","START"
CSBO "BO2",Y,Y,"REVERSE","FWD","REV"
CSBO "BO3",Y,Y,"PAN_LOCK","OPEN","LOCKED"
CSBO "BO4",Y,Y,"RUN_ENAB","DISABLE","ENABLE"
CSBO "BO5",Y,Y,"R1/2_SEL","EXT_1","EXT_2"
CSBO "BO6",Y,Y,"FLT_RSET","-","RESET"
CSBO "BO7",Y,Y,"CMD_RO_1","OFF","ON"
CSBO "BO8",Y,Y,"CMD_RO_2","OFF","ON"
CSBO "BO9",Y,Y,"CMD_RO_3","OFF","ON"
CSBO "BO10",Y,Y,"CMD_RO_4","OFF","ON"
CSBO "BO13",Y,Y,"RST_RTIM","OFF","RESET"

```

```
CSBO "BO14",Y,Y,"RST_KWH","OFF","RESET"  
CSBO "BO15",Y,Y,"PID_SEL","SET1","SET2"  
CSBO "BO16",Y,Y,"N2_LOC_C","AUTO","N2"  
CSBO "BO17",Y,Y,"N2_LOC_R","EUTO","N2"  
CSBO "BO18",Y,Y,"SAV_PRMS","OFF","SAVE"  
CSBO "BO19",Y,Y,"READ_MB","NO","READ"  
CSBO "BO20",Y,Y,"WRITE_MB","NO","WRITE"
```

FLN protocol technical data

Overview

The FLN fieldbus connection to the ACS320 drives is based on an industry standard RS-485 physical interface. The FLN (Floor Level Network) fieldbus protocol is a serial communication protocol, used by the Siemens APOGEE® system. The ACS320 interface is specified in Siemens application xxxx.

Supported features

The ACS320 supports all required FLN features.

Reports

The ACS320 provides seven pre-defined reports. Using a report request generated from the FLN fieldbus controller, select one of the following sets of points. By providing views of selected points, these reports are often easier to work with than views of the full point database.

ABB ACS320

FLN ABB drive report			
Point		Subpoint name	Data
#	Type		
01	LAO	CTLR ADDRESS	Each host FLN application (for example, CIS or Insight) controls both the particular data reported for each point, and the report format.
02	LAO	APPLICATION	
20	LAO	OVRD TIME	
29	LDO	DAY.NIGHT	

Startup

FLN start-up report			
Point		Subpoint name	Data
#	Type		
21	LDI	FWD.REV	Each host FLN application (for example, CIS or Insight) controls both the particular data reported for each point, and the report format.
22	LDO	CMD FWD.REV	
23	LDI	STOP.RUN	
24	LDO	CMD STP.STRT	
25	LDI	EXT1.2 ACT	
26	LDO	EXT1.2 CMD	
34	LDI	ENA.DIS ACT	
35	LDO	ENA.DIS CMD	
36	LDI	FLN LOC ACT	
60	LAO	INPUT REF1	

FLN start-up report			
Point		Subpoint name	Data
#	Type		
61	LAO	INPUT REF2	
68	LDO	FLN LOC CTL	
69	LDO	FLN LOC REF	
94	LDO	RESET FAULT	

Overview

FLN overview report			
Point		Subpoint name	Data
#	Type		
03	LAI	FREQ OUTPUT	Each host FLN application (for example, CIS or Insight) controls both the particular data reported for each point, and the report format.
04	LAI	PCT OUTPUT	
05	LAI	SPEED	
06	LAI	CURRENT	
07	LAI	TORQUE	
08	LAI	POWER	
09	LAI	DRIVE TEMP	
10	LAI	DRIVE KWH	
11	LAI	DRIVE MWH	
12	LAI	RUN TIME	
13	LAI	DC BUS VOLT	
14	LAI	OUTPUT VOLT	
17	LAI	MOTOR TEMP	
18	LAI	MREV COUNTER	
21	LDI	FWD.REV	
23	LDI	STOP.RUN	
25	LDI	EXT1.2 ACT	
27	LDI	DRIVE READY	
28	LDI	AT SETPOINT	
33	LDI	HANDAUTO ACT	
34	LDI	ENA.DIS ACT	
36	LDI	FLN LOC ACT	

Drive I/O

FLN drive I/O report			
Point		Subpoint name	Data
#	Type		
40	LDO	RO 1 COMMAND	Each host FLN application (for example, CIS or Insight) controls both the particular data reported for each point, and the report format.
41	LDO	RO 2 COMMAND	
42	LDO	RO 3 COMMAND	
43	LDO	RO 4 COMMAND	
46	LAO	AO 1 COMMAND	
70	LDI	DI 1 ACTUAL	
71	LDI	DI 2 ACTUAL	
72	LDI	DI 3 ACTUAL	
73	LDI	DI 4 ACTUAL	
74	LDI	DI 5 ACTUAL	
76	LDI	RO 1 ACTUAL	
77	LDI	RO 2 ACTUAL	
78	LDI	RO 3 ACTUAL	
79	LDI	RO 4 ACTUAL	

Drive Config

FLN drive config. report			
Point		Subpoint name	Data
#	Type		
30	LAO	CURRENT LIM	Each host FLN application (for example, CIS or Insight) controls both the particular data reported for each point, and the report format.
31	LAO	ACCEL TIME 1	
32	LAO	DECEL TIME 1	
48	LDO	RST RUN TIME	
49	LDO	RESET KWH	
59	LDO	LOCK PANEL	
66	LDO	SPD OUT MIN	
67	LDO	SPD OUT MAX	
95	LAO	MBOX PARAM	
96	LAO	MBOX DATA	
97	LDO	MBOX READ	
98	LDO	MBOX WRITE	

Process PID

FLN process PID report			
Point		Subpoint name	Data
#	Type		
15	LAI	PRC PID FBCK	Each host FLN application (for example, CIS or Insight) controls both the particular data reported for each point, and the report format.
16	LAI	PRC PID DEV	
50	LAO	PRC PID GAIN	
51	LAO	PRC PID ITIM	
52	LAO	PRC PID DTIM	
53	LAO	PRC PID DFIL	
54	LDO	PRC PID SEL	
60	LAO	INPUT REF1	
61	LAO	INPUT REF2	
82	LAI	AI 1 ACTUAL	
83	LAI	AI 2 ACTUAL	
84	LAI	AO 1 ACTUAL	

External PID

FLN external PID report			
Point		Subpoint name	Data
#	Type		
55	LAO	EXT PID GAIN	Each host FLN application (for example, CIS or Insight) controls both the particular data reported for each point, and the report format.
56	LAO	EXT PID ITIM	
57	LAO	EXT PID DTIM	
58	LAO	EXT PID DFIL	
62	LAO	EXT PID STPT	
63	LAI	EXT PID FBCK	
64	LAI	EXT PID DEV	
82	LAI	AI 1 ACTUAL	
83	LAI	AI 2 ACTUAL	
84	LAI	AO 1 ACTUAL	

■ Scaling drive feedback values

Feedback values are provided with units of percent, where 0% and 100% correspond to the range of the sensor being used to measure the control variable. These points have default units in Hz. If other units are required:

- Unbundle these points with appropriate slopes and intercepts.
- The new intercept equals the lowest value of the desired range.
- Calculate the new slope as follows:

$$\begin{aligned} \text{New Slope} &= \frac{(\text{Desired Range, ie, high - low values}) \times (\text{Slope of Existing Point})}{\text{Range of Existing Point}} \\ &= \frac{(60 \text{ Hz} - 0 \text{ Hz}) \times (0.01)}{100\% - 0\%} = 0.006 \end{aligned}$$

Example – You are controlling water temperature from a cooling tower using the ACS320 to control a fan. The temperature sensor has a range of 30 to 250 degrees Fahrenheit.

To unbundle the setpoint (INPUT REF 2), for commanding in degrees Fahrenheit, where 0...60 Hz is equal to 30...250° F:

New Intercept = 30 (the temperature that corresponds to 0%)

$$\begin{aligned} \text{New Slope} &= \frac{(\text{Desired Range}) \times (\text{Slope of Existing Point})}{\text{Range of Existing Point}} \\ &= \frac{(250^\circ \text{ F} - 30^\circ \text{ F}) \times (0.1)}{100\% - 0\%} = 0.22 \end{aligned}$$

To unbundle the feedback (PRC PID FBCK) for monitoring in degrees Fahrenheit:

New Intercept = 30

$$\begin{aligned} \text{New Slope} &= \frac{(\text{Desired Range}) \times (\text{Slope of Existing Point})}{\text{Range of Existing Point}} \\ &= \frac{(250^\circ \text{ F} - 30^\circ \text{ F}) \times (0.01)}{100\% - 0\%} = 0.022 \end{aligned}$$

■ Loop gains

PRC PID GAIN (Point 50) and PRC PID ITIM (Point 51) are PID parameters similar to the P and I gains in the APOGEE TECs. Because the ABB PI loop and the Siemens loop are structured differently, there is no a one-to-one correspondence between the gains. The following formulas allow translation from ABB gains to Siemens gains and vice versa:

- To convert from ABB PI gains to Siemens P and I gains:

$$P \text{ GAIN}_{\text{Siemens}} = PI \text{ GAIN}_{\text{ABB}} \times 0.0015$$

$$I \text{ GAIN}_{\text{Siemens}} = \frac{PI \text{ GAIN}_{\text{ABB}}}{PI \text{ GAIN}_{\text{ABB}}} \times 0.0015$$

- To convert from Siemens P and I gains to ABB PI gains:

$$P \text{ GAIN}_{\text{ABB}} = PI \text{ GAIN}_{\text{Siemens}} \times 667$$

$$I \text{ GAIN}_{\text{ABB}} = \frac{PI \text{ GAIN}_{\text{Siemens}}}{PI \text{ GAIN}_{\text{Siemens}}} \times 667$$

■ Point database

The following table lists the point database for FLN / ACS320 (Application 2762).

FLN Point Database								
Point		Subpoint Name	Factory Default	Engr. Units	Slope	Intercept	On Text	Off Text
#	Type							
01	LAO	CTLR ADDRESS	99	-	1	0	-	-
02	LAO	APPLICATION	2734	-	1		-	-
{03}	LAI	FREQ OUTPUT	0	Hz	0.1	0	-	-
{04}	LAI	PCT OUTPUT	0	PCT	0.1	0	-	-
{05}	LAI	SPEED	0	RPM	1	0	-	-
{06}	LAI	CURRENT	0	A	0.1		-	-
{07}	LAI	TORQUE	0	PCT	0.1	-200	-	-
{08}	LAI	POWER	0 (0)	HP (KW)	0.134 0.1	0 0	-	-
{09}	LAI	DRIVE TEMP	77 (25)	° F (° C)	0.18 (0.1)	32 0	-	-
{10}	LAI	DRIVE KWH	0	KWH	1		-	-
{11}	LAI	DRIVE MWH	0	MWH	1		-	-
{12}	LAI	RUN TIME	0	HRS	1		-	-
{13}	LAI	DC BUS VOLT	0	V	1		-	-

FLN Point Database								
Point		Subpoint Name	Factory Default	Engr. Units	Slope	Intercept	On Text	Off Text
#	Type							
{14}	LAI	OUTPUT VOLT	0	V	1		-	-
{15}	LAI	PRC PID FBCK	0	PCT	0.1		-	-
{16}	LAI	PRC PID DEV	0	PCT	0.1		-	-
{17}	LAI	MOTOR TEMP	77(25)	° F (° C)	1.8 (1)	32 0	-	-
{18}	LAI	MREV COUNTER	0	MREV	1	0	-	-
20	LAO	OVRD TIME	1	hrs	1	0	-	-
{21}	LDI	FWD.REV	FWD	-	1	0	REV	FWD
{22}	LDO	CMD FWD.REV	FWD	-	1	0	REV	FWD
{23}	LDI	STOP.RUN	STOP	-	1	0	RUN	STOP
{24}	LDO	CMD STP.STRT	STOP	-	1	0	RUN	STOP
{25}	LDI	EXT1.2 ACT	EXT1	-	1	0	EXT2	EXT1
{26}	LDO	EXT1.2 CMD	EXT1	-	1	0	EXT2	EXT1
{27}	LDI	DRIVE READY	NOTRDY	-	1	0	READY	NOTRDY
{28}	LDI	AT SETPOINT	NO	-	1	0	YES	NO
{29}	LDO	DAY.NIGHT	DAY	-	1	0	NIGHT	DAY
30	LAO	CURRENT LIM	0	A	0.1	0	-	-
31	LAO	ACCEL TIME 1	300	sec	0.1	0	-	-
32	LAO	DECEL TIME 1	300	sec	0.1	0	-	-
{33}	LDI	HANDAUTO ACT	AUTO	-	1	0	HAND	AUTO
{34}	LDI	ENA.DIS ACT	DISABL	-	1	0	ENABLE	DISABL
{35}	LDO	ENA.DIS CMD	DISABL	-	1	0	ENABLE	DISABL
{36}	LDI	FLN LOC ACT	AUTO	-	1	0	FLN	AUTO
{37}	LDI	CTL SRC	NO	-	1	0	YES	NO
{38}	LDI	FLN REF1 SRC	NO	-	1	0	YES	NO
{39}	LDI	FLN REF2 SRC	NO	-	1	0	YES	NO
{40}	LDO	RO 1 COMMAND	OFF	-	1	0	ON	OFF
{41}	LDO	RO 2 COMMAND	OFF	-	1	0	ON	OFF
{42}	LDO	RO 3 COMMAND	OFF	-	1	0	ON	OFF
{43}	LDO	RO 4 COMMAND	OFF	-	1	0	ON	OFF
{46}	LAO	AO 1 COMMAND	PCT	PCT	0.1	0	-	-
48	LDO	RST RUN TIME	NO	-	1	0	RESET	NO
49	LDO	RESET KWH	NO	-	1	0	RESET	NO
50	LAO	PRC PID GAIN	10	PCT	0.1	0	-	-
51	LAO	PRC PID ITIM	600	SEC	0.1	0	-	-

FLN Point Database								
Point		Subpoint Name	Factory Default	Engr. Units	Slope	Intercept	On Text	Off Text
#	Type							
52	LAO	PRC PID DTIM	0	SEC	0.1	0	-	-
53	LAO	PRC PID DFIL	10	SEC	0.1	0	-	-
54	LDO	PRC PID SEL	SET1	-	1	0	SET2	SET1
55	LAO	EXT PID GAIN	10	PCT	0.1	0	-	-
56	LAO	EXT PID ITIM	600	SEC	0.1	0	-	-
57	LAO	EXT PID DTIM	0	SEC	0.1	0	-	-
58	LAO	EXT PID DFIL	10	SEC	0.1	0	-	-
59	LDO	LOCK PANEL	UNLOCK	-	1	0	LOCK	UNLOCK
{60}	LAO	INPUT REF1	0	PCT	0.1	0	-	-
{61}	LAO	INPUT REF2	0	PCT	0.1	0	-	-
{62}	LAO	EXT PID STPT	0	PCT	0.1	0	-	-
{63}	LAI	EXT PID FBCK	0	PCT	0.1	0	-	-
{64}	LAI	EXT PID DEV	0	PCT	0.1	0	-	-
66	LDO	SPD OUT MIN	0	PCT	0.1	0	-	-
67	LDO	SPD OUT MAX	1000	PCT	0.1	0	-	-
{68}	LDO	FLN LOC CTL	AUTO	-	1	0	FLN	AUTO
{69}	LDO	FLN LOC REF	AUTO	-	1	0	FLN	AUTO
{70}	LDI	DI 1 ACTUAL	OFF	-	1	0	ON	OFF
{71}	LDI	DI 2 ACTUAL	OFF	-	1	0	ON	OFF
{72}	LDI	DI 3 ACTUAL	OFF	-	1	0	ON	OFF
{73}	LDI	DI 4 ACTUAL	OFF	-	1	0	ON	OFF
{74}	LDI	DI 5 ACTUAL	OFF	-	1	0	ON	OFF
{76}	LDI	RO 1 ACTUAL	OFF	-	1	0	ON	OFF
{77}	LDI	RO 2 ACTUAL	OFF	-	1	0	ON	OFF
{78}	LDI	RO 3 ACTUAL	OFF	-	1	0	ON	OFF
{79}	LDI	RO 4 ACTUAL	OFF	-	1	0	ON	OFF
{82}	LAI	AI 1 ACTUAL	0	PCT	0.1	0	-	-
{83}	LAI	AI 2 ACTUAL	0	PCT	0.1	0	-	-
{84}	LAI	AO 1 ACTUAL	0	MA	0.1	0	-	-
{86}	LDI	OK.ALARM	OK	-	1	0	ALARM	OK
{87}	LDI	OK.MAINT	OK	-	1	0	MAINT	OK
{88}	LAI	ALARM WORD 1	-	-	1	0	-	-
{89}	LAI	ALARM WORD 2	-	-	1	0	-	-
{90}	LAI	LAST FAULT	-	-	1	0	-	-
{91}	LAI	PREV FAULT 1	-	-	1	0	-	-
{92}	LAI	PREV FAULT 2	-	-	1	0	-	-
{93}	LDI	OK.FAULT	OK	-	1	0	FAULT	OK

FLN Point Database								
Point		Subpoint Name	Factory Default	Engr. Units	Slope	Intercept	On Text	Off Text
#	Type							
{94}	LDO	RESET FAULT	NO	-	1	0	RESET	NO
{95}	LAO	MBOX PARAM	-	-	1	0	-	-
{96}	LAO	MBOX DATA	-	-	1	0	-	-
{97}	LDO	MBOX READ	DONE	-	1	0	READ	DONE
{98}	LDO	MBOX WRITE	DONE	-	1	0	WRITE	DONE
{99}	LAO	ERROR STATUS	-	-	1	0	-	-

a. Points not listed are not used in this application.

b. A single value in a column means that the value is the same in English units and in SI units.

c. Point numbers that appear in brackets { } may be unbundled at the field panel.

■ Detailed point descriptions

FLN Detailed Point Descriptions			
Point		Description	Drive Parameter
1	CTRL ADDRESS	The FLN address of the drive. It can be set by FLN and by the panel.	5302
2	APPLICATION	The Application ID for FLN on the ACS320. This ID is assigned by Siemens for each unique application. It correlates directly to a particular point list approved at the time of release. Therefore, this point list shall remain fixed once approval is granted. Any changes to the point list shall require a new Application ID and re-approval by Siemens. The Application ID assigned to ACS320 is 2934.	
3	FREQ OUTPUT	The output frequency applied to the motor, in Hertz.	0103
4	PCT OUTPUT	The ratio of output frequency or speed to the corresponding maximum rating, depending on control mode. For scalar mode, it is the ratio of Output Frequency (parameter 0103) to Maximum Frequency (parameter 2008).	None. This ratio is calculated by the FLN application.
5	SPEED	The calculated speed of the motor, in RPM.	0102
6	CURRENT	The measured output current.	0104
7	TORQUE	The calculated output torque of the motor as a percentage of nominal torque.	0105
8	POWER	The measured output power in KW. The FLN point definition also supports horsepower by selecting English units.	0106
9	DRIVE TEMP	The measured heatsink temperature, in °C. The FLN point definition also supports °F by selecting English units.	0110
10	DRIVE KWH	The drive's cumulative power consumption in kilowatt-hours. This value may be reset by commanding FLN point 49, RESET KWH.	0115

FLN Detailed Point Descriptions			
Point		Description	Drive Parameter
11	DRIVE MWH	The drive's cumulative power consumption in megawatt hours. This value cannot be reset.	0141
12	RUN TIME	The drive's cumulative run time in hours. This value may be reset by commanding FLN point 48, RESET RUN TIME.	0114
13	DC BUS VOLT	The DC bus voltage level of the drive.	0107
14	OUTPUT VOLT	The AC output voltage applied to the motor.	0109
15	PRC PID FBCK	The Process PID feedback signal.	0130
16	PRC PID DEV	The deviation of the Process PID output signal from its setpoint.	0132
17	MOTOR TEMP	The measured motor temperature as set up in Group 35.	0145
18	ROTATION CNT	The motor's cumulative revolution count, in mega-revolutions.	0142
19	N/A		
20	OVRD TIME	1 of the 5 mandatory FLN points required for compatibility with Siemens control systems. It has no functionality in the drive application.	None
21	FWD.REV ACT	Indicates the rotational direction of the motor, regardless of control source (1 = REV, 0 = FWD).	
22	FWD.REV CMD	Commanded by FLN to change the rotational direction of the drive. Parameter 1001 must be set to COMM for FLN to control the direction of the motor by EXT1. Parameter 1002 must be set to COMM for FLN to control the direction of the motor by EXT2.	
23	RUN.STOP ACT	Indicates the drive's run status, regardless of control source (1 = RUN, 0 = STOP).	
24	RUN.STOP CMD	Commanded by FLN to start the drive. Parameter 1001 must be set to COMM for FLN to control the run state of the drive by EXT1. Parameter 1002 must be set to COMM for FLN to have this control.	
25	EXT1.2 ACT	Indicates whether External 1 or External 2 is the active control source (1 = EXT2, 0 = EXT1).	
26	EXT1.2 CMD	Commanded by FLN to select External 1 or External 2 as the active control source (1 = EXT2, 0 = EXT1). Parameter 1102 must be set to COMM for FLN to have this control.	
27	DRIVE READY	Indicates the drive is ready to accept a run command (1 = READY, 0 = NOTRDY).	
28	AT SETPOINT	Indicates the drive has reached its commanded setpoint (1 = YES, 0 = NO)	
29	DAY.NIGHT	1 of the 5 mandatory FLN points required for compatibility with Siemens control systems. It has no functionality in the drive application.	None
30	CURRENT LIM	Sets the output current limit of the drive.	2003
31	ACCEL TIME 1	Sets the acceleration time for Ramp 1.	2202

FLN Detailed Point Descriptions			
Point	Description	Drive Parameter	
32	DECEL TIME 1	Sets the deceleration time for Ramp 1.	2203
33	HANDAUTO ACT	Indicates whether the drive is in Hand or Auto control (1 = HAND, 0 = AUTO).	
34	ENA.DIS ACT	Indicates the status of the Run Enable command, regardless of its source (1 = ENABLE, 0 = DISABL).	
35	ENA.DIS CMD	Commanded by FLN to assert the Run Enable command (1 = ENABLE, 0 = DISABL). Parameter 1601 must be set to COMM for FLN to have this control.	
36	FLN LOC ACT	Indicates if the drive has been placed in "FLN LOCAL" mode by commanding either point 68 (FLN LOC CTL) or point 69 (FLN LOC REF). Commanding either of these points to FLN (1) "steals" control from its normal source and places in under FLN control. Note that the HAND mode of the panel has priority over FLN local control.	
37	FLN CTL SRC	Indicates if FLN is a source for control inputs (1 = YES, 0 = NO). Note that this status point is true if any of the following control inputs are from FLN: Run/Stop, Ext1/2 Select or Run Enable.	
38	FLN REF1 SRC	Indicates if FLN is the source for speed reference 1 (1 = YES, 0 = NO).	
39	FLN REF2 SRC	Indicates if FLN is the source for speed reference 2 (1 = YES, 0 = NO).	
40	RO1 COMMAND	Controls the output state of Relay 1. Parameter 1401 must be set to COMM for FLN to have this control (1 = ON, 0 = OFF).	0134, bit 0
41	RO2 COMMAND	Controls the output state of Relay 2. Access to relay 2 requires ACS320 option MREL. Parameter 1402 must be set to COMM for FLN to have this control (1 = ON, 0 = OFF).	0134, bit 2
42	RO3 COMMAND	Controls the output state of Relay 3. Access to relay 3 requires ACS320 option MREL. Parameter 1403 must be set to COMM for FLN to have this control (1 = ON, 0 = OFF).	0134, bit 3
43	RO4 COMMAND	Controls the output state of Relay 4. Access to relay 4 require ACS320 option MREL. Parameter 1410 must be set to COMM for FLN to have this control (1 = ON, 0 = OFF).	0134, bit 4
44, 45	N/A		
46	AO1 COMMAND	Controls Analog Output 1. Parameter 1501 must be set to this value for FLN to have this control.	0135 (COMM VALUE 1)
47	N/A		

FLN Detailed Point Descriptions		
Point	Description	Drive Parameter
48	RESET RUN TIME	Commanded by FLN to reset the cumulative run timer (1 = RESET, 0 = NO). The control input is rising-edge sensitive, so, once the command is issued, this point automatically returns to its inactive state. This "momentary" operation avoids any need for an explicit command to clear the point before a subsequent reset can be issued.
49	RESET KWH	Commanded by FLN to reset the cumulative kilowatt-hour counter (1 = RESET, 0 = NO). The control input is rising-edge sensitive, so, once the command is issued, this point automatically returns to its inactive state. This "momentary" operation avoids any need for an explicit command to clear the point before a subsequent reset can be issued.
50	PRC PID GAIN	Sets the proportional gain of the active Process PID set, as selected by Point 54, PRC PID SEL (1 = SET2, 0 = SET1). 4001 (SET1) 4101 (SET2)
51	PRC PID ITIM	Sets the integration time of the active Process PID set, as selected by Point 54, PRC PID SEL (1 = SET2, 0 = SET1). 4002 (SET1) 4102 (SET2)
52	PRC PID DTIM	Sets the derivation time of the active Process PID set, as selected by Point 54, PRC PID SEL (1 = SET2, 0 = SET1). 4001 (SET1) 4101 (SET2)
53	PRC PID DFIL	Sets the time constant for the error-derivative of the active Process PID set, as selected by Point 54, PRC PID SEL (1 = SET2, 0 = SET1). 4004 (SET1) 4104 (SET2)
54	PRC PID SEL	Selects the active Process PID set (1 = SET2, 0 = SET1). 4027
55	EXT PID GAIN	Sets the proportional gain of the External PID controller. 4201
56	EXT PID ITIM	Sets the integration time of the External PID controller. 4202
57	EXT PID DTIM	Sets the derivation time of the External PID controller. 4203
58	EXT PID DFIL	Sets the time constant for the error-derivative of the External PID controller. 4204
59	LOCK PANEL	Command by FLN to lock the panel and prevent parameter changes (1 = LOCK, 0 = UNLOCK). 1602
60	INPUT REF 1	Sets Input Reference 1. Parameter 1102 must be set to COMM for FLN to control this value.
61	INPUT REF 2	Sets Input Reference 2. Parameter 1106 must be set to COMM for FLN to control this value.
62	EXT PID STPT	The setpoint for the External PID controller. The function of this point requires parameter 4210, PID Setpoint Select, to be set to 19 (Internal). 4211
63	EXT PID FBCK	The External PID feedback signal. 0131
64	EXT PID DEV	The deviation of the External PID output signal from its setpoint. 0133

FLN Detailed Point Descriptions			
Point		Description	Drive Parameter
65... 67	N/A		
68	FLN LOC CTL	Commanded by FLN to temporarily "steal" start/stop control of the drive from its normal source and place it under FLN control. This functionality is analogous to placing the drive in HAND mode at the panel, with the control being taken by FLN instead. HAND mode at the panel has priority over this point. Thus, this point is only effective in temporarily taking control from the digital inputs or some other internal control functionality.	
69	FLN LOC REF	Commanded by FLN to temporarily "steal" input reference control of the drive from its normal source and place it under FLN control. This functionality is analogous to placing the drive in HAND mode at the panel, with the reference control being taken by FLN instead. HAND mode at the panel has priority over this point. Thus, this point is only effective in temporarily taking control from the analog inputs or some other internal control functionality.	
70... 81	N/A		
82	AI 1 ACTUAL	Indicates the input level of Analog Input 1.	0120
83	AI 2 ACTUAL	Indicates the input level of Analog Input 2.	0121
84	AO 1 ACTUAL	Indicates the output level of Analog Output 1.	0124
85	N/A		
86	OK.ALARM	Indicates the current alarm state of the drive (1 = ALARM, 0 = OK).	
87	OK.MAINT	Indicates the current maintenance state of the drive (1 = MAINT, 0 = OK). Maintenance triggers are configured in drive parameter Group 29.	
88	ALARM WORD1	This point is a bit-field indicating active alarms in the drive.	0308
89	ALARM WORD2	This point is a bit-field indicating active alarms in the drive.	0309
90	LAST FAULT	This point is first in the drive's fault log and indicates the most recent fault declared.	0401
91	PREV FAULT 1	This point is second in the drive's fault log and indicates the previous fault declared.	0412
92	PREV FAULT 2	This point is last in the drive's fault log and indicates the oldest fault in the log.	0413
93	OK.FAULT	Indicates the current fault state of the drive (1 = FAULT, 0 = OK).	

FLN Detailed Point Descriptions			
Point	Description	Drive Parameter	
94	RESET FAULT	Command by FLN to reset a faulted drive (1 = RESET, 0 = NO). Parameter 1604 must be set to COMM for FLN to control this state. The control input is rising-edge sensitive, so, once the command is issued, this point automatically returns to its inactive state. This "momentary" operation avoids any need for an explicit command to clear the point before a subsequent reset can be issued.	
95	MBOX PARAM	Sets the parameter to be used by the mailbox function.	
96	MBOX DATA	Sets or indicates the data value of the mailbox function.	
97	MBOX READ	Command by FLN to read the parameter value specified by Point 95, MBOX PARAM. The parameter value is returned in Point 96, MBOX DATA. The control input is rising-edge sensitive, so, once the command is issued, this point automatically returns to its inactive state. This "momentary" operation avoids any need for an explicit command to clear the point before a subsequent reset can be issued.	
98	MBOX WRITE	Command by FLN to write the data value specified by Point 96, MBOX DATA, to the parameter value specified by Point 95, MBOX PARAM. The control input is rising-edge sensitive, so, once the command is issued, this point automatically returns to its inactive state. This "momentary" operation avoids any need for an explicit command to clear the point before a subsequent reset can be issued.	
99	ERROR STATUS	1 of the 5 mandatory FLN points required for compatibility with Siemens control systems. It has no functionality in the drive application.	None

BACnet protocol technical data

Binary input object instance summary

The following table summarizes the Binary input objects supported:

Instance ID	Object Name	Description	Active/Inactive Text	Present Value Access Type
BI0	RO 1 ACT	Indicates status of Relay Output 1.	ON/OFF	R
BI1	RO 2 ACT	Indicates status of Relay Output 2 (requires OREL-xx option).	ON/OFF	R
BI2	RO 3 ACT	Indicates status of Relay Output 3 (requires OREL-xx option).	ON/OFF	R
BI3	RO 4 ACT	Indicates status of Relay Output 4 (requires OREL-xx option).	ON/OFF	R
BI6	DI 1 ACT	Indicates status of Digital Input 1.	ON/OFF	R
BI7	DI 2 ACT	Indicates status of Digital Input 2.	ON/OFF	R
BI8	DI 3 ACT	Indicates status of Digital Input 3.	ON/OFF	R
BI9	DI 4 ACT	Indicates status of Digital Input 4.	ON/OFF	R
BI10	DI 5 ACT	Indicates status of Digital Input 5.	ON/OFF	R
BI12	TO ACT	Indicates status of Transistor Output.	ON/OFF	R

Note: For Present Value Access Types, R = Read-only, W = Writeable, C = Commandable. Commandable values support priority arrays & relinquish defaults.

Binary output object instance summary

The following table summarizes the Binary output objects supported:

Instance ID	Object Name	Description	Active/Inactive Text	Present Value Access Type
BO0	RO1 CMD	Controls output state of Relay 1.	ON/OFF	C
BO1	RO2 CMD	Controls output state of Relay 2. (requires OREL-xx option).	ON/OFF	C
BO2	RO3 CMD	Controls output state of Relay 3. (requires OREL-xx option).	ON/OFF	C
BO3	RO4 CMD	Controls output state of Relay 4. (requires OREL-xx option).	ON/OFF	C
BO6	TO CMD	Controls output state of Transistor	ON/OFF	C

Note: For Present Value Access Types, R = Read-only, W = Writeable, C = Commandable. Commandable values support priority arrays & relinquish defaults.

■ Binary value object instance summary

The following table summarizes the Binary value objects supported:

Instance ID	Object Name	Description	Active/Inactive Text	Present Value Access Type
BV0	RUN/STOP ACT	Indicates the Run status of the drive, regardless of the control source.	RUN/STOP	R
BV1	FWD/REV ACT	Indicates the rotation direction of the motor, regardless of control source.	REV/FWD	R
BV2	FAULT ACT	Indicates the fault status of the drive.	FAULT/OK	R
BV3	EXT 1/2 ACT	Indicates which control source is active: External 1 or External 2.	EXT2/EXT1	R
BV4	HAND/AUTO ACT	Indicates which control mode the drive is in: Hand or Auto.	HAND/AUTO	R
BV5	ALARM ACT	Indicates the alarm status of the drive.	ALARM/OK	R
BV6	MAINT REQ	Indicates the maintenance status of the drive.	MAINT/OK	R
BV7	DRIVE READY	Indicates whether the drive is ready to accept a run command.	READY/NOT READY	R
BV8	AT SETPOINT	Indicates whether the drive is at the commanded setpoint.	YES/NO	R
BV9	RUN ENA ACT	Indicates the Run Enable command status, regardless of the control source.	ENABLE/DISABLE	R
BV10	RUN/STOP CMD	Command to start the drive (drive must be configured for BACnet control).	RUN/STOP	C
BV11	FWD/REV CMD	Command to change the rotational direction of motor (drive must be configured for BACnet control).	REV/FWD	C
BV12	RUN ENA CMD	Command to assert Run Enable (drive must be configured for BACnet control).	ENABLE/DISABLE	C
BV13	EXT 1/2 CMD	Command to select External 1 or External 2 as the active control source (drive must be configured for BACnet control).	EXT2/EXT1	C

Instance ID	Object Name	Description	Active/Inactive Text	Present Value Access Type
BV14	FAULT RESET	Command to reset a fault (drive must be configured for BACnet control).	RESET/NO	C
BV15	MBOX READ	Command to read parameter specified by AV25, MBOX PARAM. The parameter value is returned in AV26, MBOX DATA.	READ/RESET	W
BV16	MBOX WRITE	Command to write data value specified by AV26, MBOX DATA, to the parameter value specified by AV25, MBOX PARAM.	WRITE/RESET	W
BV17	LOCK PANEL	Command to lock the panel and prevent parameter changes.	LOCK/UNLOCK	W
BV18	CTL OVERRIDE CMD	Commands the drive into BACnet Control Override. In this mode, BACnet acquires drive control from its normal source. Note that the HAND mode of the panel has priority over BACnet Control Override.	ON/OFF	C
BV19	CTL OVERRIDE ACT	Indicates if drive is placed in BACnet Control Override by commanding BV18. In this mode, BACnet acquires drive control from its normal source. Note that HAND mode of the panel has priority over BACnet control Override.	ON/OFF	R
BV20	START ENABLE 1	Command to assert Start Enable1 (drive must be configured for BACnet control).	ENABLE/DISABLE	C
BV21	START ENABLE 2	Command to assert Start Enable 2 (drive must be configured for BACnet control).	ENABLE/DISABLE	C

Instance ID	Object Name	Description	Active/Inactive Text	Present Value Access Type
BV22*	HEATING CMD	Command to automatically assert Motor Heating DC current injection, when drive is stopped (drive must be configured for BACnet control). In this mode, "DISABLE" turns off the ongoing Motor Heating operation immediately (after the drive has received the command).	ENABLE/DISABLE	C
BV23*	HEATING STS	Indicates the status of Motor Heating DC current injection (drive must be configured for BACnet control). "ON" means there is actual heating current flowing in the motor circuit.	ON/OFF	R

*Object instance applies for US regional variant only.

Note: For Present Value Access Types, R = Read-only, W = Writeable, C = Commandable. Commandable values support priority arrays & relinquish defaults.

■ Analog input object instance summary

The following table summarizes the Analog input objects supported:

Instance ID	Object Name	Description	Units	Present Value Access Type
AI0	ANALOG INPUT 1	Indicates the input level of Analog Input 1.	Percent	R
AI1	ANALOG INPUT 2	Indicates the input level of Analog Input 2.	Percent	R

Note: For Present Value Access Types, R = Read-only, W = Writeable, C = Commandable. Commandable values support priority arrays & relinquish defaults.

■ Analog output object instance summary

The following table summarizes the Analog output objects supported:

Instance ID	Object Name	Description	Units	Present Value Access Type
AO0	AO 1 COMMAND	Controls Analog Output 1 (drive must be configured for BACnet control).	Percent	C

Note: For Present Value Access Types, R = Read-only, W = Writeable, C = Commandable. Commandable values support priority arrays & relinquish defaults.

■ Analog value object instance summary

The following table summarizes the Analog value objects supported:

Instance ID	Object Name	Description	Units	Present Value Access Type
AV0	OUTPUT SPEED	Indicates motor speed.	RPM	R
AV1	OUTPUT FREQ	Indicates output frequency.	Hertz	R
AV2	DC BUS VOLT	Indicates DC bus voltage.	Volts	R
AV3	OUTPUT VOLT	Indicates AC output voltage.	Volts	R
AV4	CURRENT	Indicates output current of the drive.	Amps	R
AV5	TORQUE	Indicates output torque of the motor as a percentage of nominal torque.	Percent	R
AV6	POWER	Indicates output power in kW.	Kilowatts	R
AV7	DRIVE TEMP	Indicates heatsink temperature.	°C	R
AV8	KWH (R)	Indicates the resettable energy usage of the drive (reset by writing zero).	kWh	W
AV9	KWH (NR)	Indicates the cumulative energy usage of the drive. The value cannot be reset.	kWh	R
AV10	PRC PID FBCK	Process PID feedback signal.	Percent	R
AV11	PRC PID DEV	Deviation of the Process PID output signal from its setpoint.	Percent	R
AV12	EXT PID FBCK	External PID feedback signal.	Percent	R
AV13	EXT PID DEV	Deviation of External PID output signal from its setpoint.	Percent	R
AV14	RUN TIME (R)	Indicates the resettable run time of the drive (reset by writing zero).	Hours	W
AV15	MOTOR TEMP	Indicates the motor temperature as set up in Group 35: Motor temp meas.	°C	R
AV16	INPUT REF 1	Sets the input Reference 1 (drive must be configured for BACnet control).	Percent	C
AV17	INPUT REF 2	Sets the input Reference 2 (drive must be configured for BACnet control).	Percent	C
AV18	LAST FLT	Indicates most recent fault in the fault log.	None	R
AV19	PREV FLT 1	Indicates previous fault in the fault log.	None	R
AV20	PREV FLT 2	Indicates the oldest fault in the fault log.	None	R
AV21	AO 1 ACT	Indicates output level of Analog Output 1.	Milliamps	R
AV23	ACCEL1 TIME	Sets Ramp1 acceleration time.	Seconds	W
AV24	DECEL1 TIME	Sets Ramp1 deceleration time.	Seconds	W
AV25	MBOX PARAM	Sets the parameter to be used by the mailbox function. See BV15 and BV16.	None	W
AV26	MBOX DATA	Sets (W) or indicates (R) as the data value of mailbox function (see BV15 and BV16).	None	W

Instance ID	Object Name	Description	Units	Present Value Access Type
AV27	EXT PID STPT	Setpoint for external PID controller (drive must be configured for BACnet control).	Percent	C
AV28*	HEATING CURRENT	Sets motor heating DC current reference (percent of motor nominal current).	Percent	W

*Object instance applies for US regional variant only.

Note: For Present Value Access Types, R = Read-only, W = Writeable, C = Commandable. Commandable values support priority arrays & relinquish defaults.

BACnet quick-start sequence

The following steps summarize the process for enabling and configuring BACnet on the ACS320:

1. Enable BACnet protocol: Set drive parameter *9802 COMM PROT SEL* = BACNET (5).

Note: If you cannot see the desired selection on the panel, your drive does not have that protocol software in the application memory.

 - To confirm this selection, read drive parameter *5301 EFB PROTOCOL ID*. It should read x5xx (where “x” is any value).
 2. Place the BACnet channel in “reset”: Set drive parameter *5302 EFB STATION ID* = 0.
 - This setting holds the BACnet communication channel in reset while remaining settings are completed.
 3. Define the MS/TP baud rate.
 - Set drive parameter *5303 EFB BAUD RATE* = appropriate value.
 4. Define the Device Object Instance ID.
 - To define a specific device object instance value, use drive parameters 5311 and 5317 (object instance values must be unique and in the range 1 to 4,194,303).
 - To use the drive’s MS/TP MAC ID as the device object instance value, set drive parameter 5311 and 5317 = 0.
 5. Define a unique MS/TP MAC ID. Set drive parameter *5302 EFB STATION ID* = appropriate value.
 - Once this parameter is set to a non-zero value, current BACnet settings are “latched” and used for communication until the channel is reset.
 - In order to participate in MS/TP token passing, the MAC ID used must be within the limits defined by other masters’ “Max Master” property.
 6. Confirm proper BACnet communication.
 - When BACnet communication is operating properly, drive parameter 5316 EFB PAR 16 (the MS/TP token counter), should be continually increasing.
 - Drive parameter *5306 EFB UART ERRORS*, should be stable.
-

BACnet protocol implementation conformance statement (PICS)

■ **BACnet Standard Device Profile**

This version of ACS320 BACnet fully conforms to the 'Application-Specific Controller' standard device profile (B-ASC).

■ **Services Supported**

The following services are supported by the ACS320:

- I-Am (Response to Who-Is, also broadcast on power-up & other reset)
- I-Have (Response to Who-Has)
- ReadProperty
- WriteProperty
- DeviceCommunicationControl
- ReinitializeDevice

■ **Data Link Layer options**

The ACS320 implements:

- MS/TP (Master), baud rate(s): 9600, 19200, 38400, 76800
- MS/TP (Slave), baud rate(s): 9600, 19200, 38400, 76800

■ **MAC ID / Device Object Instance**

The ACS320 supports separate MAC ID and Device Object Instance parameters:

- Set the MAC ID using drive parameter *5302 EFB STATION ID*. Default: 5302 = 1.
- Set the Device Object Instance ID using drive parameters 5311 and 5317. Default: Both 5311 and 5317 = 0, which causes the MAC ID to “double” as the Device Object Instance. For Device Object Instance values not linked to the MAC ID, set ID values using 5311 and 5317:
 - For IDs in the range 1 to 65,535: Parameter 5311 sets the ID directly (5317 must be 0). For example, the following values set the ID to 49,134:
5311 = 49134 and 5317 = 0.
 - For IDs > 65,335: The ID equals 5311's value plus 10,000 times 5317's value. For example, the following values set the ID to 71,234:
5311 = 1234 and 5317 = 7.

■ **Max Info Frames Property**

Configure the Device Object Max Info Frames property using drive parameter 5312. Default: 5312 = 1.

■ Max Master Property

Configure the Device Object Max Master property using drive parameter 5313.
Default: 5313 = 127.

■ MS/TP Token Counter

Parameter 5316 stores the count of MS/TP tokens passed to the associated node.

BACnet protocol implementation conformance statement

This statement is part of this standard and is required for its use.

Date:	December 2015
Vendor Name:	ABB, Inc
Product Name:	Low Voltage AC Motor Drive
Product Model Number:	ACS320-xxE (European regional variant) ACS320-xxU (USA regional variant)
Applications Software Version:	403C (European regional variant) 4050 (USA regional variant)
Firmware Revision:	0528
BACnet Protocol Revision:	7
Product Description:	The ACS320 is a high-performance adjustable frequency drive specifically designed for commercial automation applications. This product supports native BACnet, connecting directly to the MS/TP LAN. All standard MS/TP baud rates are supported, as well as master mode functionality. Over BACnet, the drive can be fully controlled as a standard adjustable frequency drive. In addition, up to 13 configurable I/O ports are available over BACnet for user application.
BACnet Standardized Device Profile (Annex L):	<input type="checkbox"/> BACnet Operator Workstation (B-OWS) <input type="checkbox"/> BACnet Building Controller (B-BC) <input type="checkbox"/> BACnet Advanced Application Controller (B-AAC) <input checked="" type="checkbox"/> BACnet Application Specific Controller (B-ASC) <input type="checkbox"/> BACnet Smart Sensor (B-SS) <input type="checkbox"/> BACnet Smart Actuator (B-SA)
List all BACnet Interoperability Building Blocks Supported (Annex K):	DS-RP-B, DS-WP-B, DM-DDB-B, DM-DOB-B, DM-DCC-B, DM-RD-B.
Segmentation Capability:	<input type="checkbox"/> Segmented requests supported. Window Size ____ <input type="checkbox"/> Segmented responses supported. Window Size ____

Standard Object Types Supported:	Object instantiation is static, that is objects cannot be created or deleted. See Object/Property support matrix tables from page 337.
Data Link Layer Options:	<input type="checkbox"/> BACnet IP, (Annex J) <input type="checkbox"/> BACnet IP, (Annex J), Foreign Device <input type="checkbox"/> ISO 8802-3, Ethernet (Clause 7) <input type="checkbox"/> ANSI/ATA 878.1, 2.5 Mb. ARCNET (Clause 8) <input type="checkbox"/> ANSI/ATA 878.1, EIA-485 ARCNET (Clause 8), baud rate(s) ____ <input checked="" type="checkbox"/> MS/TP master (Clause 9), baud rate(s): 9600, 19200, 38400, 76800 <input checked="" type="checkbox"/> MS/TP slave (Clause 9), baud rate(s): 9600, 19200, 38400, 76800 <input type="checkbox"/> Point-To-Point, EIA 232 (Clause 10), baud rate(s): ____ <input type="checkbox"/> Point-To-Point, modem, (Clause 10), baud rate(s): ____ <input type="checkbox"/> LonTalk, (Clause 11), medium: _____ <input type="checkbox"/> Other: _____
Device Address Binding: Is static device binding supported? (This is currently necessary for two-way communication with MS/TP slaves and certain other devices.)	<input type="checkbox"/> Yes <input checked="" type="checkbox"/> No
Networking Options:	<input type="checkbox"/> Router, Clause 6 - List all routing configurations, eg, ARCNET-Ethernet, Ethernet-MS/TP, etc. <input type="checkbox"/> Annex H, BACnet Tunneling Router over IP <input type="checkbox"/> BACnet/IP Broadcast Management Device (BBMD) Does the BBMD support registrations by Foreign Devices? <input type="checkbox"/> Yes <input type="checkbox"/> No
Character Sets Supported: Indicating support for multiple character sets does not imply that they can all be supported simultaneously.	<input checked="" type="checkbox"/> ANSI X3.4 <input type="checkbox"/> IBM™/Microsoft™ DBCS <input type="checkbox"/> ISO 8859-1 <input type="checkbox"/> ISO 10646 (UCS-2) <input type="checkbox"/> ISO 10646 (UCS-4) <input type="checkbox"/> JIS C 6226
If this product is a communication gateway, describe the types of non-BACnet equipment/network(s) that the gateway supports:	

BACnet object definitions

■ Object/Property support matrix

The following table summarizes the object types/properties supported:

Property	Object Type						
	Device	Binary Input	Binary Output	Binary Value	Analog Input	Analog Output	Analog Value
Object Identifier	✓	✓	✓	✓	✓	✓	✓
Object Name	✓	✓	✓	✓	✓	✓	✓
Object Type	✓	✓	✓	✓	✓	✓	✓
System Status	✓						
Vendor Name	✓						
Vendor Identifier	✓						
Model Name	✓						
Firmware Revision	✓						
Appl Software Revision	✓						
Protocol Version	✓						
Protocol Revision	✓						
Services Supported	✓						
Object Types Supported	✓						
Object List	✓						
Max APDU Length	✓						
Segmentation Support	✓						
APDU Timeout	✓						
Number APDU Retries	✓						
Max Master	✓						
Max Info Frames	✓						
Device Address Binding	✓						
Database Revision	✓						
Present Value		✓	✓	✓	✓	✓	✓
Status Flags		✓	✓	✓	✓	✓	✓
Event State		✓	✓	✓	✓	✓	✓
Out-of-Service		✓	✓	✓	✓	✓	✓
Units					✓	✓	✓
Priority Array			✓	✓ *		✓	✓ *
Relinquish Default			✓	✓ *		✓	✓ *
Polarity		✓	✓				
Active Text		✓	✓	✓			
Inactive Text		✓	✓	✓			

* For commandable values only.

Modbus protocol technical data

■ Overview

The Modbus® protocol was introduced by Modicon, Inc. for use in control environments featuring Modicon programmable controllers. Due to its ease of use and implementation, this common PLC language was quickly adopted as a de-facto standard for integration of a wide variety of master controllers and slave devices.

Modbus is a serial, asynchronous protocol. Transactions are half-duplex, featuring a single Master controlling one or more Slaves. While RS232 can be used for point-to-point communication between a single Master and a single Slave, a more common implementation features a multi-drop EIA-485 network with a single Master controlling multiple Slaves. The ACS320 features EIA-485 for its Modbus physical interface.

RTU

The Modbus specification defines two distinct transmission modes: ASCII and RTU. The ACS320 supports RTU only.

Feature summary

The following Modbus function codes are supported by the ACS320.

Function	Code (Hex)	Description
Read Coil Status	0x01	Read discrete output status. For the ACS320, the individual bits of the control word are mapped to Coils 1...16. Relay outputs are mapped sequentially beginning with Coil 33 (eg, RO1=Coil 33).
Read Discrete Input Status	0x02	Read discrete inputs status. For the ACS320, the individual bits of the status word are mapped to Inputs 1...16 or 1...32, depending on the active profile. Terminal inputs are mapped sequentially beginning with Input 33 (eg, DI1=Input 33).
Read Multiple Holding Registers	0x03	Read multiple holding registers. For the ACS320, the entire parameter set is mapped as holding registers, as well as command, status and reference values.
Read Multiple Input Registers	0x04	Read multiple input registers. For the ACS320, the 2 analog input channels are mapped as input registers 1 & 2.
Force Single Coil	0x05	Write a single discrete output. For the ACS320, the individual bits of the control word are mapped to Coils 1...16. Relay outputs are mapped sequentially beginning with Coil 33 (eg, RO1=Coil 33).
Write Single Holding Register	0x06	Write single holding register. For the ACS320, the entire parameter set is mapped as holding registers, as well as command, status and reference values.
Diagnostics	0x08	Perform Modbus diagnostics. Subcodes for Query (0x00), Restart (0x01) & Listen Only (0x04) are supported.
Force Multiple Coils	0x0F	Write multiple discrete outputs. For the ACS320, the individual bits of the control word are mapped to Coils 1...16. Relay outputs are mapped sequentially beginning with Coil 33 (eg, RO1=Coil 33).

Function	Code (Hex)	Description
Write Multiple Holding Registers	0x10	Write multiple holding registers. For the ACS320, the entire parameter set is mapped as holding registers, as well as command, status and reference values.
Read/Write Multiple Holding Registers	0x17	This function combines functions 0x03 and 0x10 into a single command.

Mapping summary

The following table summarizes the mapping between the ACS320 (parameters and I/O) and Modbus reference space. For details, see section [Modbus addressing](#) below.

ACS320	Modbus Reference	Supported Function Codes
<ul style="list-style-type: none"> Control Bits Relay Outputs 	Coils(0xxxx)	<ul style="list-style-type: none"> 01 – Read Coil Status 05 – Force Single Coil 15 – Force Multiple Coils
<ul style="list-style-type: none"> Status Bits Discrete Inputs 	Discrete Inputs(1xxxx)	<ul style="list-style-type: none"> 02 – Read Input Status
<ul style="list-style-type: none"> Analog Inputs 	Input Registers(3xxxxx)	<ul style="list-style-type: none"> 04 – Read Input Registers
<ul style="list-style-type: none"> Parameters Control/Status Words References 	Holding Registers(4xxxx)	<ul style="list-style-type: none"> 03 – Read 4X Registers 06 – Preset Single 4X Register 16 – Preset Multiple 4X Registers 23 – Read/Write 4X Registers

Communication profiles

When communicating by Modbus, the ACS320 supports multiple profiles for control and status information. Parameter [5305 EFB CTRL PROFILE](#) selects the profile used.

- ABB DRV LIM – This profile is based on the PROFIBUS interface, and is discussed in detail in the following sections.
- DCU PROFILE – Another profile is called the DCU PROFILE profile. It extends the control and status interface to 32 bits, and is the internal interface between the main drive application and the embedded fieldbus environment.
- ABB DRV FULL – This profile is also based on the PROFIBUS interface, and supports two control word bits not supported by the ABB DRV LIM profile.

■ Modbus addressing

With Modbus, each function code implies access to a specific Modbus reference set. Thus, the leading digit is not included in the address field of a Modbus message.

Note: The drive supports the zero-based addressing of the Modbus specification. Holding register 40002 is addressed as 0001 in a Modbus message. Similarly, coil 33 is addressed as 0032 in a Modbus message.

Refer again to section [Mapping summary](#) above. The following sections describe, in detail, the mapping to each Modbus reference set.

0xxxx Mapping – Modbus Coils. The drive maps the following information to the 0xxxx Modbus set called Modbus Coils:

- Bit-wise map of the CONTROL WORD (selected using parameter [5305 EFB CTRL PROFILE](#)). The first 32 coils are reserved for this purpose.
- Relay output states, numbered sequentially beginning with coil 00033.

The following table summarizes the 0xxxx reference set:

Modbus Ref.	Internal Location (All Profiles)	(5305 = 0)	(5305 = 1)	(5305 = 2)
00001	– Bit 0	OFF1*	STOP	OFF1*
00002	– Bit 1	OFF2*	START	OFF2*
00003	– Bit 2	OFF3*	REVERSE	OFF3*
00004	– Bit 3	START	LOCAL	START
00005	– Bit 4	N/A	RESET	RAMP_OUT_ZERO*
00006	– Bit 5	RAMP_HOLD*	EXT2	RAMP_HOLD*
00007	– Bit 6	RAMP_IN_ZERO*	RUN_DISABLE	RAMP_IN_ZERO*
00008	– Bit 7	RESET	STPMODE_R	RESET
00009	– Bit 8	N/A	STPMODE_EM	N/A
00010	– Bit 9	N/A	STPMODE_C	N/A
00011	– Bit 10	N/A	RAMP_2	REMOTE_CMD*
00012	– Bit 11	EXT2	RAMP_OUT_0	EXT2
00013	– Bit 12	N/A	RAMP_HOLD	N/A
00014	– Bit 13	N/A	RAMP_IN_0	N/A
00015	– Bit 14	N/A	REQ_LOCALLOCK	N/A
00016	– Bit 15	N/A	Reserved	N/A
00017	– Bit 16	Does not apply	FBLOCAL_CTL	Does not apply
00018	– Bit 17		FBLOCAL_REF	
00019	– Bit 18		START_DISABLE1	
00020	– Bit 19		START_DISABLE2	
00021... 00032	Reserved	Reserved	Reserved	Reserved

Modbus Ref.	Internal Location (All Profiles)	(5305 = 0)	(5305 = 1)	(5305 = 2)
00033	relay output 1	Relay Output 1	Relay Output 1	Relay Output 1
00034	relay output 2	Relay Output 2	Relay Output 2	Relay Output 2
00035	relay output 3	Relay Output 3	Relay Output 3	Relay Output 3
00036	relay output 4	Relay Output 4	Relay Output 4	Relay Output 4

* = Active low

For the 0xxxx registers:

- Status is always readable.
- Forcing is allowed by user configuration of the drive for fieldbus control.
- Additional relay outputs are added sequentially.

The drive supports the following Modbus function codes for coils:

Function Code	Description
01	Read coil status
05	Force single coil
15 (0x0F Hex)	Force multiple coils

1xxxx Mapping – Modbus Discrete Inputs. The drive maps the following information to the 1xxxx Modbus set called Modbus Discrete Inputs:

- Bit-wise map of the STATUS WORD (selected using parameter *5305 EFB CTRL PROFILE*). The first 32 inputs are reserved for this purpose.
- Discrete hardware inputs, numbered sequentially beginning with input 33.

The following table summarizes the 1xxxx reference set:

Modbus Ref.	Internal Location (All Profiles)	(5305 = 0 or 2)	(5305 = 1)
10001	– Bit 0	RDY_ON	READY
10002	– Bit 1	RDY_RUN	ENABLED
10003	– Bit 2	RDY_REF	STARTED
10004	– Bit 3	TRIPPED	RUNNING
10005	– Bit 4	OFF_2_STA*	ZERO_SPEED
10006	– Bit 5	OFF_3_STA*	ACCELERATE
10007	– Bit 6	SWC_ON_INHIB	DECELERATE
10008	– Bit 7	ALARM	AT_SETPOINT
10009	– Bit 8	AT_SETPOINT	LIMIT
10010	– Bit 9	REMOTE	SUPERVISION
10011	– Bit 10	ABOVE_LIMIT	REV_REF
10012	– Bit 11	EXT2	REV_ACT
10013	– Bit 12	RUN_ENABLE	PANEL_LOCAL
10014	– Bit 13	N/A	FIELDBUS_LOCAL
10015	– Bit 14	N/A	EXT2_ACT

Modbus Ref.	Internal Location (All Profiles)	(5305 = 0 or 2)	(5305 = 1)
10016	– Bit 15	N/A	FAULT
10017	– Bit 16	Reserved	ALARM
10018	– Bit 17	Reserved	REQ_MAINT
10019	– Bit 18	Reserved	DIRLOCK
10020	– Bit 19	Reserved	LOCALLOCK
10021	– Bit 20	Reserved	CTL_MODE
10022	– Bit 21	Reserved	Reserved
10023	– Bit 22	Reserved	Reserved
10024	– Bit 23	Reserved	Reserved
10025	– Bit 24	Reserved	Reserved
10026	– Bit 25	Reserved	Reserved
10027	– Bit 26	Reserved	REQ_CTL
10028	– Bit 27	Reserved	REQ_REF1
10029	– Bit 28	Reserved	REQ_REF2
10030	– Bit 29	Reserved	REQ_REF2EXT
10031	– Bit 30	Reserved	ACK_STARTINH
10032	– Bit 31	Reserved	ACK_OFF_ILCK
10033		DI1	DI1
10034		DI2	DI2
10035		DI3	DI3
10036		DI4	DI4
10037		DI5	DI5

* = Active low

For the 1xxxx registers:

- Additional discrete inputs are added sequentially.

The drive supports the following Modbus function codes for discrete inputs:

Function Code	Description
02	Read input status

3xxxx Mapping – Modbus Inputs. The drive maps the following information to the 3xxxx Modbus addresses called Modbus input registers:

- Any user defined analog inputs.

The following table summarizes the input registers:

Modbus Reference	Internal Location (All Profiles)	Remarks
30001	ai1	This register shall report the level of Analog Input 1 (0...100%).
30002	ai2	This register shall report the level of Analog Input 2 (0...100%).

The drive supports the following Modbus function codes for 3xxxx registers:

Function Code	Description
04	Read 3xxxx input status

4xxxx Register Mapping. The drive maps its parameters and other data to the 4xxxx holding registers as follows:

- 40001...40099 map to drive control and actual values. These registers are described in the table below.
- 40101...49999 map to drive parameters 0101...9999. Register addresses that do not correspond to drive parameters are invalid. If there is an attempt to read or write outside the parameter addresses, the Modbus interface returns an exception code to the controller.

The following table summarizes the 4xxxx drive control registers 40001...40099 (for 4xxxx registers above 40099, see the drive parameter list, for example, 40102 is parameter [0102](#)):

Modbus Register	Access	Remarks	
40001	R/W	Maps directly to the profile. Supported only if 5305 = 0 or 2 (ABB Drives profile). Parameter 5319 holds a copy in hex format.	
40002	Reference 1	R/W	Range = 0...+20000 (scaled to 0...1105 REF1 MAX, or -20000...0 (scaled to 1105 REF1 MAX...0).
40003	Reference 2	R/W	Range = 0...+10000 (scaled to 0...1108 REF2 MAX, or -10000...0 (scaled to 1108 REF2 MAX...0).
40004		R	Maps directly to the profile. Supported only if 5305 = 0 or 2 (ABB Drives profile). Parameter 5320 holds a copy in hex format.
40005	Actual 1 (select using 5310)	R	By default, stores a copy of 0103 OUTPUT FREQ. Use parameter 5310 to select a different actual value for this register.
40006	Actual 2 (select using 5311)	R	By default, stores a copy of 0104 CURRENT. Use parameter 5311 to select a different actual value for this register.
40007	Actual 3 (select using 5312)	R	By default, stores nothing. Use parameter 5312 to select an actual value for this register.
40008	Actual 4 (select by 5313)	R	By default, stores nothing. Use parameter 5313 to select an actual value for this register.
40009	Actual 5 (select using 5314)	R	By default, stores nothing. Use parameter 5314 to select an actual value for this register.

Modbus Register		Access	Remarks
40010	Actual 6 (select using 5315)	R	By default, stores nothing. Use parameter 5315 to select an actual value for this register.
40011	Actual 7 (select using 5316)	R	By default, stores nothing. Use parameter 5316 to select an actual value for this register.
40012	Actual 8 (select using 5317)	R	By default, stores nothing. Use parameter 5317 to select an actual value for this register.
40013	Actual 9 (select using 5321)	R	By default, stores nothing. Use parameter 5321 to select an actual value for this register. Supported by STD Modbus only.
40014	Actual 10 (select using 5322)	R	By default, stores nothing. Use parameter 5322 to select an actual value for this register. Supported by STD Modbus only.
40031	LSW	R/W	Maps directly to the Least Significant Word of the DCU profile's CONTROL WORD. Supported only if 5305 = 1. See parameter 0301.
40032	MSW	R/W	Maps directly to the Most Significant Word of the DCU profile's CONTROL WORD. Supported only if 5305 = 1. See parameter 0302.
40033	LSW	R	Maps directly to the Least Significant Word of the DCU profile's STATUS WORD. Supported only if 5305 = 1. See parameter 0303.
40034	MSW	R	Maps directly to the Most Significant Word of the DCU profile's STATUS WORD. Supported only if 5305 = 1. See parameter 0304.
40080	Actual 11 (select using 5323)	R/W	Use parameter 5323 to select an actual value for this register. Supported by STD Modbus only.
40081	Actual 12 (select using 5324)	R/W	Use parameter 5324 to select an actual value for this register. Supported by STD Modbus only.
40082	Actual 13 (select using 5325)	R/W	Use parameter 5325 to select an actual value for this register. Supported by STD Modbus only.
40083	Actual 14 (select using 5326)	R/W	Use parameter 5326 to select an actual value for this register. Supported by STD Modbus only.
40084	Actual 15 (select using 5327)	R/W	Use parameter 5327 to select an actual value for this register. Supported by STD Modbus only.
40085	Actual 16 (select using 5328)	R/W	Use parameter 5328 to select an actual value for this register. Supported by STD Modbus only.
40086	Actual 17 (select using 5329)	R/W	Use parameter 5329 to select an actual value for this register. Supported by STD Modbus only.
40087	Actual 18 (select using 5330)	R/W	Use parameter 5330 to select an actual value for this register. Supported by STD Modbus only.
40088	Actual 19 (select using 5331)	R/W	Use parameter 5331 to select an actual value for this register. Supported by STD Modbus only.
40089	Actual 20 (select using 5332)	R/W	Use parameter 5332 to select an actual value for this register. Supported by STD Modbus only.

For the Modbus protocol, drive parameters in group 53 report the parameter mapping to 4xxxx Registers.

Code	Description
5310	EFB PAR 10 Specifies the parameter mapped to Modbus register 40005.
5311	EFB PAR 11 Specifies the parameter mapped to Modbus register 40006.
5312	EFB PAR 12 Specifies the parameter mapped to Modbus register 40007.
5313	EFB PAR 13 Specifies the parameter mapped to Modbus register 40008.
5314	EFB PAR 14 Specifies the parameter mapped to Modbus register 40009.
5315	EFB PAR 15 Specifies the parameter mapped to Modbus register 40010.
5316	EFB PAR 16 Specifies the parameter mapped to Modbus register 40011.
5317	EFB PAR 17 Specifies the parameter mapped to Modbus register 40012.
5318	Reserved.
5319	EFB PAR 19 Holds a copy (in hex) of the CONTROL WORD, Modbus register 40001.
5320	EFB PAR 20 Holds a copy (in hex) of the STATUS WORD, Modbus register 40004.
5321	MDB DATA IN 1 Specifies the parameter mapped to Modbus register 40013.
5322	MDB DATA IN 2 Specifies the parameter mapped to Modbus register 40014.
5323	MDB DATA OUT 1 Specifies the parameter mapped to Modbus register 40080.
5324	MDB DATA OUT 2 Specifies the parameter mapped to Modbus register 40081.
5325	MDB DATA OUT 3 Specifies the parameter mapped to Modbus register 40082.
5326	MDB DATA OUT 4 Specifies the parameter mapped to Modbus register 40083.
5327	MDB DATA OUT 5 Specifies the parameter mapped to Modbus register 40084.
5328	MDB DATA OUT 6 Specifies the parameter mapped to Modbus register 40085.
5329	MDB DATA OUT 7 Specifies the parameter mapped to Modbus register 40086.
5330	MDB DATA OUT 8 Specifies the parameter mapped to Modbus register 40087.

Code	Description
5331	MDB DATA OUT 9 Specifies the parameter mapped to Modbus register 40088.
5332	MDB DATA OUT 10 Specifies the parameter mapped to Modbus register 40089.

Except where restricted by the drive, all parameters are available for both reading and writing. The parameter writes are verified for the correct value, and for a valid register addresses.

Note: Parameter writes through standard Modbus are always volatile, in other words, modified values are not automatically stored to permanent memory. Use parameter [1607 PARAM. SAVE](#) to save all altered values.

The drive supports the following Modbus function codes for 4xxxx registers:

Function Code	Description
03	Read holding 4xxxx registers
06	Preset single 4xxxx register
16 (0x10 Hex)	Preset multiple 4xxxx registers
23 (0x17 Hex)	Read/write 4xxxx registers

Actual values

The contents of the register addresses 40005...40012 are actual values and are:

- Specified using parameters 5310...5317.
- Read-only values containing information on the operation of the drive.
- 16-bit words containing a sign bit and a 15-bit integer.
- When negative values, written as the two's complement of the corresponding positive value.
- Scaled as described earlier in [Actual value scaling](#).

Exception codes

Exception codes are serial communication responses from the drive. The drive supports the standard Modbus exception codes defined below.

Exception Code	Meaning
01	Unsupported command
02	The data address received in the query is not allowable. It is not a defined parameter/group.
03	A value contained in the query data field is not an allowable value for the drive, because it is one of the following: Outside min. or max. limits. Parameter is read-only. Message is too long. Parameter write not allowed when start is active. Parameter write not allowed when factory macro is selected.

ABB control profiles technical data

■ Overview

ABB Drives profile

The ABB Drives profile provides a standard profile that can be used on multiple protocols, including Modbus and the protocols available on the FBA module. Two implementations of the ABB Drives profile are available:

- ABB DRV FULL – This implementation standardizes the control interface with ACS600 and ACS800 drives.
- ABB DRV LIM – This implementation standardizes the control interface with ACH400 drives. This implementation does not support two control word bits supported by ABB DRV FULL.

Except as noted, the following “ABB Drives profile” descriptions apply to both implementations.

DCU profile

The DCU profile extends the control and status interface to 32 bits, and is the internal interface between the main drive application and the embedded fieldbus environment.

Control word

The CONTROL WORD is the principal means for controlling the drive from a fieldbus system. The fieldbus master station sends the CONTROL WORD to the drive. The drive switches between states according to the bit-coded instructions in the CONTROL WORD. Using the CONTROL WORD (ABB Drives profile version) requires that:

- The drive is in remote (REM) control.
- The serial communication channel is defined as the source for controlling commands (set using parameters [1001 EXT1 COMMANDS](#), [1002 EXT2 COMMANDS](#) and [1102 EXT1/EXT2 SEL](#)).
- The serial communication channel used is configured to use an ABB control profile. For example, to use the control profile ABB DRV FULL, requires both parameter [9802 COMM PROT SEL](#) = 1 (STD MODBUS), and parameter [5305 EFB CTRL PROFILE](#) = 2 (ABB DRV FULL).

ABB Drives profile

The following table and the state diagram later in this sub-section describe the CONTROL WORD content for the ABB Drives profile.

ABB Drives Profile (EFB) CONTROL WORD				
Bit	Name	Value	Commanded State	Comments
0	OFF1 CONTROL	1	READY TO OPERATE	Enter READY TO OPERATE.
		0	EMERGENCY OFF	Drive ramps to stop according to currently active deceleration ramp (2203 or 2205) Normal command sequence: <ul style="list-style-type: none"> • Enter OFF1 ACTIVE. • Proceed to READY TO SWITCH ON, unless other interlocks (OFF2, OFF3) are active.
1	OFF2 CONTROL	1	OPERATING	Continue operation (OFF2 inactive)
		0	EMERGENCY OFF	Drive coasts to stop. Normal command sequence: <ul style="list-style-type: none"> • Enter OFF2 ACTIVE. • Proceed to SWITCHON INHIBITED.
2	OFF3 CONTROL	1	OPERATING	Continue operation (OFF3 inactive)
		0	EMERGENCY STOP	Drive stops within in time specified by parameter 2208. Normal command sequence: <ul style="list-style-type: none"> • Enter OFF3 active. • Proceed to switch on inhibited. <p>⚠ WARNING! Be sure motor and driven equipment can be stopped using this mode.</p>
3	INHIBIT OPERATION	1	OPERATION ENABLED	Enter OPERATION ENABLED (Note the Run enable signal must be active. See parameter 1601. If parameter 1601 is set to COMM, this bit also activates the Run Enable signal.)
		0	OPERATION INHIBITED	Inhibit operation. Enter OPERATION INHIBITED.
4	Unused (ABB DRV LIM)			
	RAMP_OUT_ZERO (ABB DRV FULL)	1	NORMAL OPERATION	Enter RAMP FUNCTION GENERATOR: ACCELERATION ENABLED.
		0	RFG OUT ZERO	Force ramp function generator output to Zero. Drive ramps to stop (current and DC voltage limits in force).
5	RAMP_HOLD	1	RFG OUT ENABLED	Enable ramp function. Enter RAMP FUNCTION GENERATOR: ACCELERATION ENABLED.
		0	RFG OUT HOLD	Halt ramping (Ramp Function Generator output held)

ABB Drives Profile (EFB) CONTROL WORD				
Bit	Name	Value	Commanded State	Comments
6	RAMP_IN_ZERO	1	RFG INPUT ENABLED	Normal operation. Enter OPERATING.
		0	RFG INPUT ZERO	Force Ramp Function Generator input to zero.
7	RESET	0=>1	RESET	Fault reset if an active fault exists (Enter SWITCH-ON INHIBITED). Effective if 1604 = COMM.
		0	OPERATING	Continue normal operation
8...9	Unused			
10	Unused (ABB DRV LIM)			
	REMOTE_CMD (ABB DRV FULL)	1		Fieldbus control enabled.
		0		<ul style="list-style-type: none"> CW ≠ 0 or Ref ≠ 0: Retain last CW and Ref. CW = 0 and Ref = 0: Fieldbus control enabled. Ref and deceleration/acceleration ramp are locked.
11	EXT CTRL LOC	1	EXT2 SELECT	Select external control location 2 (EXT2). Effective if 1102 = COMM.
		0	EXT1 SELECT	Select external control location 1 (EXT1). Effective if 1102 = COMM.
12...15	Unused			

DCU profile

The following tables describe the CONTROL WORD content for the DCU profile.

DCU Profile CONTROL WORD (See Parameter 0301)				
Bit	Name	Value	Command/Req.	Comments
0	STOP	1	Stop	Stops according to either the stop mode parameter or the stop mode requests (bits 7 and 8).
		0	(no op)	
1	START	1	Start	Simultaneous STOP and START commands result in a stop command.
		0	(no op)	
2	REVERSE	1	Reverse direction	This bit XOR'd with the sign of the reference defines direction.
		0	Forward direction	
3	LOCAL	1	Local mode	When the fieldbus sets this bit, it steals control and the drive moves to fieldbus local control mode.
		0	External mode	
4	RESET	-> 1	Reset	Edge sensitive.
		other	(no op)	
5	EXT2	1	Switch to EXT2	
		0	Switch to EXT1	

DCU Profile CONTROL WORD (See Parameter 0301)

Bit	Name	Value	Command/Req.	Comments
6	RUN_DISABLE	1	Run disable	Inverted run enable.
		0	Run enable on	
7	STPMODE_R	1	Normal ramp stop mode	
		0	(no op)	
8	STPMODE_EM	1	Emergency ramp stop mode	
		0	(no op)	
9	STPMODE_C	1	Coast stop mode	
		0	(no op)	
10	RAMP_2	1	Ramp pair 2	
		0	Ramp pair 1	
11	RAMP_OUT_0	1	Ramp output to 0	
		0	(no op)	
12	RAMP_HOLD	1	Ramp freeze	
		0	(no op)	
13	RAMP_IN_0	1	Ramp input to 0	
		0	(no op)	
14	RREQ_LOCALLOC	1	Local mode lock	In lock, the drive will not switch to local mode.
		0	(no op)	
15	Reserved			

DCU Profile CONTROL WORD (See Parameter 0302)

Bit	Name	Value	Function	Comments
16	FBLOCAL_CTL	1	Fieldbus local mode for control word requested. Example: If the drive is in remote control and the start/stop direction command source is DI for external control location 1 (EXT1): by setting bit 16 to value 1, the start/stop/direction is controlled by the fieldbus command word.	
		0	No fieldbus local mode	
17	FBLOCAL_REF	1	Fieldbus local mode Control word for reference requested.	See example in bit 16 FBLOCAL_CTL.
		0	No fieldbus local mode.	
18	START_DISABLE1	1	No Start enable.	Effective if parameter <i>1608</i> setting is COMM.
		0	Enable Start.	

DCU Profile CONTROL WORD (See Parameter 0302)				
Bit	Name	Value	Function	Comments
19	START_DISABLE2	1	No Start enable.	Effective if parameter 1609 setting is COMM.
		0	Enable Start.	
20...21	Reserved			
22	MOTOR_HEAT	1	Start motor heating.	See parameter 2115 option COMM.
		0	Stop motor heating.	
23...26	Reserved			
27	REF_CONST	1	Constant speed ref.	These bits are only for supervision purposes.
		0	(no op)	
28	REF_AVE	1	Average speed ref.	
		0	(no op)	
29	LINK_ON	1	Master is detected in link	
		0	Link is down	
30	REQ_STARTINH	1	Start inhibit request is pending	Not supported by STD Modbus.
		0	Start inhibit request is OFF	
31	OFF_INTERLOCK	1	Panel OFF button pressed	For the control panel (or PC tool) this is the OFF button interlock.
		0	(no op)	

■ Status word

The contents of the STATUS WORD is status information, sent by the drive to the master station.

ABB Drives profile

The following table and the state diagram later in this sub-section describe the status word content for the ABB Drives profile.

ABB Drives Profile (EFB) STATUS WORD			
Bit	Name	Value	Description (Correspond to states/boxes in the state diagram)
0	RDY_ON	1	READY TO SWITCH ON
		0	NOT READY TO SWITCH ON
1	RDY_RUN	1	READY TO OPERATE
		0	OFF1 ACTIVE
2	RDY_REF	1	OPERATION ENABLED
		0	OPERATION INHIBITED
3	TRIPPED	0...1	FAULT
		0	No fault

ABB Drives Profile (EFB) STATUS WORD			
Bit	Name	Value	Description (Correspond to states/boxes in the state diagram)
4	OFF_2_STA	1	OFF2 INACTIVE
		0	OFF2 ACTIVE
5	OFF_3_STA	1	OFF3 INACTIVE
		0	OFF3 ACTIVE
6	SWC_ON_INHIB	1	SWITCH-ON INHIBIT ACTIVE
		0	SWITCH-ON INHIBIT NOT ACTIVE
7	ALARM	1	Warning/alarm (See chapter Fault tracing section for details on alarms.)
		0	No warning/alarm
8	AT_SETPOINT	1	OPERATING. Actual value equals (within tolerance limits) the reference value.
		0	Actual value is outside tolerance limits (not equal to reference value).
9	REMOTE	1	Drive control location: REMOTE (EXT1 or EXT2)
		0	Drive control location: LOCAL
10	ABOVE_LIMIT	1	Supervised parameter's value \geq supervision high limit. Bit remains "1" until supervised parameter's value < supervision low limit. See Group 32: Supervision .
		0	Supervised parameter's value < supervision low limit. Bit remains "0" until supervised parameter's value > supervision high limit. See Group 32: Supervision .
11	EXT CTRL LOC	1	External control location 2 (EXT2) selected
		0	External control location 1 (EXT1) selected
12	EXT RUN ENABLE	1	External Run Enable signal received
		0	No External Run Enable signal received
13... 15	Unused		

DCU profile

The following tables describe the STATUS WORD content for the DCU profile.

DCU Profile STATUS WORD (See Parameter 0303)			
Bit	Name	Value	Status
0	READY	1	Drive is ready to receive start command.
		0	Drive is not ready.
1	ENABLED	1	External run enable signal received.
		0	No external run enable signal received.
2	STARTED	1	Drive has received start command.
		0	Drive has not received start command.
3	RUNNING	1	Drive is modulating.
		0	Drive is not modulating.
4	ZERO_SPEED	1	Drive is at zero speed.
		0	Drive has not reached zero speed.
5	ACCELERATE	1	Drive is accelerating.
		0	Drive is not accelerating.
6	DECELERATE	1	Drive is decelerating.
		0	Drive is not decelerating.
7	AT_SETPOINT	1	Drive is at setpoint.
		0	Drive has not reached setpoint.
8	LIMIT	1	Operation is limited by Group 20 settings.
		0	Operation is within Group 20 settings.
9	SUPERVISION	1	A supervised parameter (Group 32) is outside its limits.
		0	All supervised parameters are within limits.
10	REV_REF	1	Drive reference is in reverse direction.
		0	Drive reference is in forward direction.
11	REV_ACT	1	Drive is running in reverse direction.
		0	Drive is running in forward direction.
12	PANEL_LOCAL	1	Control is in control panel (or PC tool) local mode.
		0	Control is not in control panel local mode.
13	FIELDBUS_LOCAL	1	Control is in fieldbus local mode (steals control panel local).
		0	Control is not in fieldbus local mode.
14	EXT2_ACT	1	Control is in the EXT2 mode.
		0	Control is in the EXT1 mode.
15	FAULT	1	Drive is in a fault state.
		0	Drive is not in a fault state.

DCU Profile STATUS WORD (See Parameter 0304)			
Bit	Name	Value	Status
16	ALARM	1	An alarm is on.
		0	No alarms are on.
17	REQ_MAINT	1	A maintenance request is pending.
		0	No maintenance request is pending.
18	DIRLOCK	1	Direction lock is ON. (Direction change is locked out.)
		0	Direction lock is OFF.
19	LOCALLOCK	1	Local mode lock is ON. (Local mode is locked out.)
		0	Local mode lock is OFF.
20	CTL_MODE	1	Drive is in vector control mode.
		0	Drive is in scalar control mode.
21...25	Reserved		
26	REQ_CTL	1	Control word requested in this channel.
		0	(no op)
27	REQ_REF1	1	Reference 1 requested in this channel.
		0	Reference 1 is not requested in this channel.
28	REQ_REF2	1	Reference 2 requested in this channel.
		0	Reference 2 is not requested in this channel.
29	REQ_REF2EXT	1	External PID reference 2 requested in this channel.
		0	External PID reference 2 is not requested in this channel.
30	ACK_STARTINH	1	A start inhibit from this channel is granted.
		0	A start inhibit from this channel is not granted.
31	ACK_OFF_ILCK	1	Start inhibit due to OFF button
		0	Normal operation

■ State diagram

ABB Drives profile

To illustrate the operation of the state diagram, the following example (ABB DRV LIM implementation of the ABB Drives profile) uses the control word to start the drive:

- First, the requirements for using the CONTROL WORD must be met. See above.
- When the power is first connected, the state of the drive is not ready to switch on. See dotted lined path () in the state diagram below.
- Use the CONTROL WORD to step through the state machine states until the OPERATING state is reached, meaning that the drive is running and follows the given reference. See table below.

Step	CONTROL WORD Value	Description
1	CW = 0000 0000 0000 0110 <div style="display: flex; justify-content: space-around; width: 100%;"> <div style="text-align: center;"> bit 15</div> <div style="text-align: center;"> bit 0</div> </div>	This CW value changes the drive state to READY TO SWITCH ON.
2		Wait at least 100 ms before proceeding.
3	CW = 0000 0000 0000 0111	This CW value changes the drive state to READY TO OPERATE.
4	CW = 0000 0000 0000 1111	This CW value changes the drive state to OPERATION ENABLED. The drive starts, but will not accelerate.
5	CW = 0000 0000 0010 1111	This CW value releases the ramp function generator (RFG) output, and changes the drive state to RFG: ACCELERATOR ENABLED.
6	CW = 0000 0000 0110 1111	This CW value releases the ramp function generator (RFG) output, and changes the drive state to OPERATING. The drive accelerates to the given reference and follows the reference.

The state diagram below describes the start-stop function of CONTROL WORD (CW) and STATUS WORD (SW) bits for the ABB Drives profile.

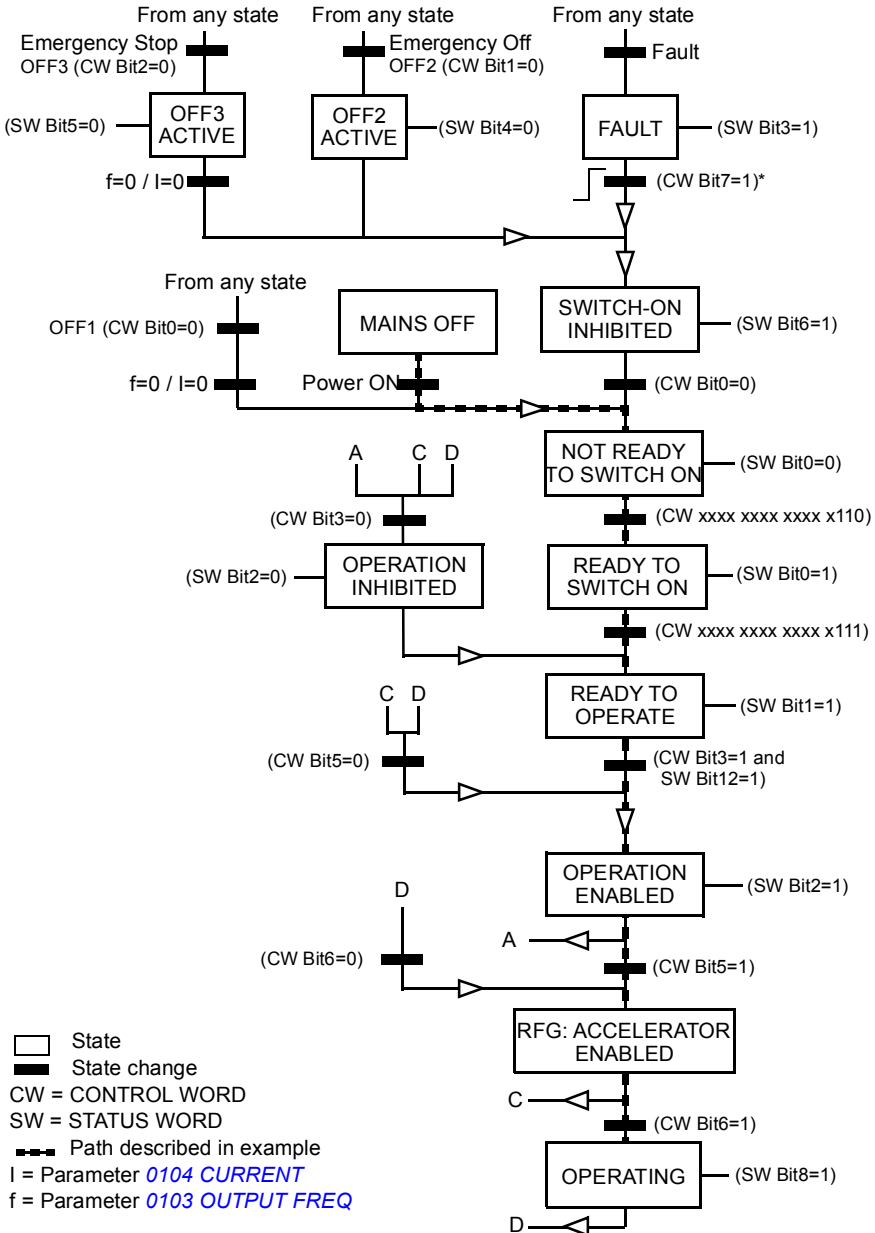

*This state transition also occurs if the fault is reset from any other source (eg, digital input).

■ Reference scaling

ABB Drives and DCU profiles

The following table describes REFERENCE scaling for the ABB Drives profile.

ABB Drives and DCU Profiles				
Reference	Range	Reference Type	Scaling	Remarks
REF1	-32767 ... +32767	Frequency	-20000 = -(par. 1105) 0 = 0 +20000 = (par. 1105) (20000 corresponds to 100%)	Final reference limited by 1104/1105. Actual motor speed limited by 2007/2008 (frequency).
REF2	-32767 ... +32767	Frequency	-10000 = -(par. 1108) 0 = 0 +10000 = (par. 1108) (10000 corresponds to 100%)	Final reference limited by 1107/1108. Actual motor speed limited by 2007/2008 (frequency).
		PID Reference	-10000 = -(par. 1108) 0 = 0 +10000 = (par. 1108) (10000 corresponds to 100%)	Final reference limited by 4012/4013 (PID set1) or 4112/4113 (PID set2).

Note: The setting of parameter *1104 REF1 MIN* and *1107 REF2 MIN* has no effect on the scaling of references.

When parameter *1103 REF1 SELECT* or *1106 REF2 SELECT* is set to COMM+AI1 or COMM*AI1, the reference is scaled as follows:



ABB Drives and DCU Profiles	
Reference	AI Reference Scaling
REF1	<p>%)</p> <p style="text-align: center;">Fieldbus Reference Correction Coefficient</p> <p style="text-align: center;">200%</p> <p style="text-align: center;">100%</p> <p style="text-align: center;">0%</p> <p style="text-align: center;">0% 50% 100%</p> <p style="text-align: right;">AI1 Input Signal</p> <p>$(100 - 0.5 * (\text{par. 1105}))\%$</p>
REF2	<p>%)</p> <p style="text-align: center;">Fieldbus Reference Correction Coefficient</p> <p style="text-align: center;">200%</p> <p style="text-align: center;">100%</p> <p style="text-align: center;">0%</p> <p style="text-align: center;">0% 50% 100%</p> <p style="text-align: right;">AI1 Input Signal</p> <p>$(100 + 0.5 * (\text{Par. 1108}))\%$</p> <p>$(100 - 0.5 * (\text{par. 1108}))\%$</p>
REF2	<p>%)</p> <p style="text-align: center;">Fieldbus Reference Correction Coefficient</p> <p style="text-align: center;">200%</p> <p style="text-align: center;">100%</p> <p style="text-align: center;">0%</p> <p style="text-align: center;">0% 50% 100%</p> <p style="text-align: right;">AI1 Input Signal</p>

Reference handling

Use *Group 10: Start/Stop/Dir* parameters to configure for control of rotation direction for each control location (EXT1 and EXT2). The following diagrams illustrate how *Group 10: Start/Stop/Dir* parameters and the sign of the fieldbus reference interact to produce REFERENCE values (REF1 and REF2). Note, fieldbus references are bipolar, that is they can be positive or negative.

ABB Drives Profile		
Parameter	Value Setting	AI Reference Scaling
1003	1 ()	
1003	2 ()	
1003	3 (request)	

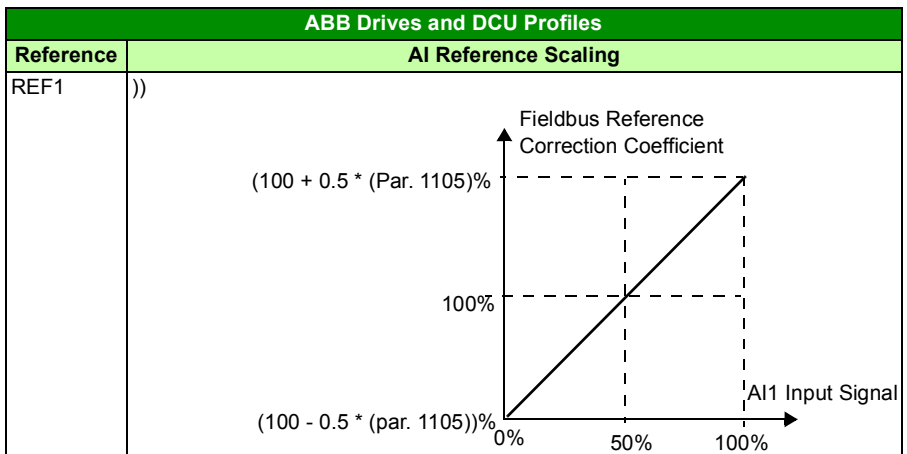
13

Fault tracing

Contents of this chapter

The chapter tells how to reset faults and view fault history. It also lists all alarm and fault messages including the possible cause and corrective actions.

Safety



WARNING! Only qualified electricians are allowed to maintain the drive. Read the safety instructions in chapter [Safety](#) on page [15](#) before you work on the drive.



Alarm and fault indications

Fault is indicated with a red LED. See section [LEDs](#) on page [383](#).

An alarm or fault message on the panel display indicates abnormal drive status. Using the information given in this chapter most alarm and fault causes can be identified and corrected. If not, contact an ABB representative.

The four digit code number in parenthesis after the fault is for the fieldbus communication. (See chapter [Fieldbus control](#) on page [285](#).)

How to reset

The drive can be reset either by pressing the keypad key  (Basic Control Panel) or  (Assistant Control Panel), through digital input or fieldbus, or by switching the supply voltage off for a while. The source for the fault reset signal is selected by parameter [1604 FAULT RESET SEL](#). When the fault has been removed, the motor can be restarted.

Fault history

When a fault is detected, it is stored in the Fault history. The latest faults are stored together with the time stamp.

Parameters *0401 LAST FAULT*, *0412 PREVIOUS FAULT 1* and *0413 PREVIOUS FAULT 2* store the most recent faults. Parameters *0404...0409* show drive operation data at the time the latest fault occurred. The Assistant control panel provides additional information about the fault history. See section *Fault logger mode* on page *72* for more information.

Alarm messages generated by the drive

CODE	ALARM	CAUSE	WHAT TO DO
2001	OVERCURRENT <i>0308</i> bit 0 (programmable fault function <i>1610</i>)	Output current limit controller is active.	Check motor load. Check acceleration time (<i>2202</i> and <i>2205</i>). Check motor and motor cable (including phasing). Check ambient conditions. Load capacity decreases if installation site ambient temperature exceeds 40 °C. See section <i>Derating</i> on page <i>388</i> .
2002	OVERVOLTAGE <i>0308</i> bit 1 (programmable fault function <i>1610</i>)	DC overvoltage controller is active.	Check deceleration time (<i>2203</i> and <i>2206</i>). Check input power line for static or transient overvoltage.
2003	UNDERVOLTAGE <i>0308</i> bit 2 (programmable fault function <i>1610</i>)	DC undervoltage controller is active.	Check input power supply.
2004	DIR LOCK <i>0308</i> bit 3	Change of direction is not allowed.	Check the settings of parameter <i>1003 DIRECTION</i> .
2005	IO COMM <i>0308</i> bit 4 (programmable fault function <i>3018</i> , <i>3019</i>)	Fieldbus communication break	Check status of fieldbus communication. See chapter <i>Fieldbus control</i> on page <i>285</i> . Check fault function parameter settings. Check connections. Check if master can communicate.
2006	AI1 LOSS <i>0308</i> bit 5 (programmable fault function <i>3001</i> , <i>3021</i>)	Analog input AI1 signal has fallen below limit defined by parameter <i>3021 AI1 FAULT LIMIT</i> .	Check fault function parameter settings. Check for proper analog control signal levels. Check connections.
2007	AI2 LOSS <i>0308</i> bit 6 (programmable fault function <i>3001</i> , <i>3021</i>)	Analog input AI2 signal has fallen below limit defined by parameter <i>3022 AI2 FAULT LIMIT</i> .	Check fault function parameter settings. Check for proper analog control signal levels. Check connections.
2008	PANEL LOSS <i>0308</i> bit 7 (programmable fault function <i>3002</i>)	Control panel selected as active control location for drive has ceased communicating.	Check panel connection. Check fault function parameters. Check control panel connector. Refit control panel in mounting platform. If drive is in external control mode (REM) and is set to accept start/stop, direction commands or references via control panel: Check <i>Group 10: Start/Stop/Dir</i> and <i>Group 11: Reference select</i> settings.

CODE	ALARM	CAUSE	WHAT TO DO
2009	DEVICE OVERTEMP 0308 bit 8	Drive IGBT temperature is excessive. Alarm limit is 120 °C.	Check ambient conditions. See also section Derating on page 388 . Check air flow and fan operation. Check motor power against unit power.
2010	MOTOR TEMP 0305 bit 9 (programmable fault function 3005...3009 / 3503)	Motor temperature is too high (or appears to be too high) due to excessive load, insufficient motor power, inadequate cooling or incorrect start-up data.	Check motor ratings, load and cooling. Check start-up data. Check fault function parameters.
		Measured motor temperature has exceeded alarm limit set by parameter 3503 ALARM LIMIT .	Check value of alarm limit. Check that actual number of sensors corresponds to value set by parameter (2501 SENSOR TYPE). Let motor cool down. Ensure proper motor cooling: Check cooling fan, clean cooling surfaces, etc.
2012	MOTOR STALL 0308 bit 11 (programmable fault function 3010...3012)	Motor is operating in stall region due to, eg, excessive load or insufficient motor power.	Check motor load and drive ratings. Check fault function parameters.
2013 ¹⁾	AUTORESET 0308 bit 12	Automatic reset alarm	Check parameter Group 31: Automatic reset settings.
2014 ¹⁾	AUTOCHANGE 0308 bit 13	PFA autochange function is active.	See parameter Group 81: PFA control . See also section SPFC control on page 140 .
2015	PFC I LOCK 0308 bit 14	PFA interlocks are active.	Drive cannot start <ul style="list-style-type: none"> any motor (when Autochange is used) the speed regulated motor (when Autochange is not used). See parameter group Group 81: PFA control .
2018 ¹⁾	PID SLEEP 3009 bit 1	Sleep function has entered sleeping mode.	See parameter Group 40: Process PID set 1...Group 41: Process PID set 2 .
2020	OVERRIDE	Override mode is activated. See Group 17: Override .	See sections Commissioning the override mode and Changing the override parameters .
2021	START ENABLE 1 MISSING 3009 bit 4	No Start Enable 1 signal received	Check parameter 1608 START ENABLE 1 settings. Check digital input connections. Check fieldbus communication settings.

CODE	ALARM	CAUSE	WHAT TO DO
2022	START ENABLE 2 MISSING 3009 bit 5	No Start Enable 2 signal received	Check parameter 1609 START ENABLE 2 settings. Check digital input connections. Check fieldbus communication settings.
2023	EMERGENCY STOP 3009 bit 6	Drive has received emergency stop command and ramps to stop according to ramp time defined by parameter 2208 EMERG DEC TIME .	Check that it is safe to continue operation. Return emergency stop push button to normal position.
2025	FIRST START 3009 bit 8	Motor identification magnetization is on. This alarm belongs to normal start-up procedure.	Wait until drive indicates that motor identification is completed.
2026	INPUT PHASE LOSS 3009 bit 9 (programmable fault function 3016)	Intermediate circuit DC voltage is oscillating due to missing input power line phase or blown fuse. Alarm is generated when DC voltage ripple exceeds 14% of nominal DC voltage.	Check input power line fuses. Check for input power supply imbalance. Check fault function parameters.
2027	USER LOAD CURVE 3009 bit 10	Condition defined by 3701 USER LOAD C MODE has been valid longer than half of the time set by 3703 USER LOAD C TIME .	See parameter Group 37: User load curve .
2028	START DELAY 3009 bit 11	Start delay in progress	See parameter 2113 START DELAY .
2030	INLET LOW 3009 bit 13	Pressure at pump/fan inlet too low	Check for a closed valve on the inlet side of the pump/fan. Check piping for leaks. See parameter Group 44: Pump protection .
2031	OUTLET HIGH 3009 bit 14	Pressure at pump/fan outlet too high	Check piping for blocks. See parameter Group 44: Pump protection .
2032	PIPE FILL 3009 bit 15	Pipe fill in progress	See parameters 4421...4426 .
2033	INLET VERY LOW 0310 bit 0	Pressure at pump/fan inlet too low	Check for a closed valve on the inlet side of the pump/fan. Check piping for leaks. See parameter Group 44: Pump protection .

CODE	ALARM	CAUSE	WHAT TO DO
2034	OUTLET VERY HIGH <i>0310</i> bit 1	Pressure at pump/fan outlet too high	Check piping for blocks. See parameter <i>Group 44: Pump protection</i> .
2038	MOTOR HEATING ACTIVE <i>2104</i> bit 1	Motor heating is activated with parameter <i>2104</i> .	See parameter <i>2115 MOT. HEATING SEL</i> .

¹⁾ Even when the relay output is configured to indicate alarm conditions (eg, parameter *1401 RELAY OUTPUT 1* = 5 (ALARM) or 16 (FLT/ALARM)), this alarm is not indicated by a relay output.

Alarms generated by the Basic control panel

The Basic control panel indicates control panel alarms with a code, A5xxx.

ALARM CODE	CAUSE	WHAT TO DO
5001	Drive is not responding.	Check panel connection.
5002	Incompatible communication profile	Contact your local ABB representative.
5010	Corrupted panel parameter backup file	Retry parameter upload. Retry parameter download.
5011	Drive is controlled from another source.	Change drive control to local control mode.
5012	Direction of rotation is locked.	Enable change of direction. See parameter 1003 DIRECTION .
5013	Panel control is disabled because start inhibit is active.	Start from the panel is not possible. Reset the emergency stop command or remove the 3-wire stop command before starting from the panel. See parameters 1001 EXT1 COMMANDS , 1002 EXT2 COMMANDS and 2109 EMERG STOP SEL .
5014	Panel control is disabled because of drive fault.	Reset drive fault and retry.
5015	Panel control is disabled because local control mode lock is active.	Deactivate local control mode lock and retry. See parameter 1606 LOCAL LOCK .
5018	Parameter default value is not found.	Contact your local ABB representative.
5019	Writing non-zero parameter value is prohibited.	Only parameter reset is allowed.
5020	Parameter or parameter group does not exist or parameter value is inconsistent.	Contact your local ABB representative.
5021	Parameter or parameter group is hidden.	Contact your local ABB representative.
5022	Parameter is write protected.	Parameter value is read-only and cannot be changed.
5023	Parameter change is not allowed, when drive is running.	Stop drive and change parameter value.
5024	Drive is executing task.	Wait until task is completed.
5025	Software is being uploaded or downloaded.	Wait until upload/download is complete.
5026	Value is at or below minimum limit.	Contact your local ABB representative.
5027	Value is at or above maximum limit.	Contact your local ABB representative.
5028	Invalid value	Contact your local ABB representative.
5029	Memory is not ready.	Retry.

ALARM CODE	CAUSE	WHAT TO DO
5030	Invalid request	Contact your local ABB representative.
5031	Drive is not ready for operation, eg due to low DC voltage.	Check input power supply.
5032	Parameter error	Contact your local ABB representative.
5040	Parameter download error. Selected parameter set is not in current parameter backup file.	Perform upload function before download.
5041	Parameter backup file does not fit into memory.	Contact your local ABB representative.
5042	Parameter download error. Selected parameter set is not in current parameter backup file.	Perform upload function before download.
5043	No start inhibit	
5044	Parameter backup file restoring error	Check that file is compatible with drive.
5050	Parameter upload aborted	Retry parameter upload.
5051	File error	Contact your local ABB representative.
5052	Parameter upload has failed.	Retry parameter upload.
5060	Parameter download aborted	Retry parameter download.
5062	Parameter download has failed.	Retry parameter download.
5070	Panel backup memory write error	Contact your local ABB representative.
5071	Panel backup memory read error	Contact your local ABB representative.
5080	Operation is not allowed because drive is not in local control mode.	Switch to local control mode.
5081	Operation is not allowed because of active fault.	Check cause of fault and reset fault.
5083	Operation is not allowed because parameter lock is on.	Check parameter <i>1602 PARAMETER LOCK</i> setting.
5084	Operation is not allowed because drive is performing task.	Wait until task is completed and retry.
5085	Parameter download from source to destination drive has failed.	Check that source and destination drive types are same, ie, ACS320. See the type designation label of the drive.
5086	Parameter download from source to destination drive has failed.	Check that source and destination drive type designations are the same. See type designation labels of the drives.

ALARM CODE	CAUSE	WHAT TO DO
5087	Parameter download from source to destination drive has failed because parameter sets are incompatible.	Check that source and destination drive information are same. See parameters in Group 33: Information .
5088	Operation has failed because of drive memory error.	Contact your local ABB representative.
5089	Download has failed because of CRC error.	Contact your local ABB representative.
5090	Download has failed because of data processing error.	Contact your local ABB representative.
5091	Operation has failed because of parameter error.	Contact your local ABB representative.
5092	Parameter download from source to destination drive has failed because parameter sets are incompatible.	Check that source and destination drive information are same. See parameters in Group 33: Information .

Fault messages generated by the drive

CODE	FAULT	CAUSE	WHAT TO DO
0001	OVERCURRENT (2310) <i>0305</i> bit 0	Output current has exceeded trip level.	Check motor load. Check acceleration time (<i>2202</i> and <i>2505</i>). Check motor and motor cable (including phasing). Check ambient conditions. Load capacity decreases if installation site ambient temperature exceeds 40 °C. See section <i>Derating</i> on page <i>388</i> .
0002	DC OVERVOLT (3210) <i>0305</i> bit 1	Excessive intermediate circuit DC voltage. DC overvoltage trip limit is 420 V for 200 V drives and 840 V for 400 V drives.	Check that overvoltage controller is on. Check input power line for static or transient overvoltage. Check deceleration time (<i>2203</i> , <i>2206</i>).
0003	DEV OVERTEMP (4210) <i>0305</i> bit 2	Drive IGBT temperature is excessive. Fault trip limit is 135 °C.	Check ambient conditions. See also section <i>Derating</i> on page <i>388</i> . Check air flow and fan operation. Check motor power against unit power.
0004	SHORT CIRC (2340) <i>0305</i> bit 3	Short circuit in motor cable(s) or motor	Check motor and motor cable.
0006	DC UNDERVOLT (3220) <i>0305</i> bit 5	Intermediate circuit DC voltage is not sufficient due to missing input power line phase, blown fuse, rectifier bridge internal fault or too low input power.	Check that undervoltage controller is on (parameter <i>2006 UNDERVOLT CTRL</i>). Check input power supply and fuses.
0007	AI1 LOSS (8110) <i>0305</i> bit 6 (programmable fault function <i>3001</i> , <i>3021</i>)	Analog input AI1 signal has fallen below limit defined by parameter <i>3021 AI1 FAULT LIMIT</i> .	Check fault function parameter settings. Check for proper analog control signal levels. Check connections.
0008	AI2 LOSS (8110) <i>0305</i> bit 7 (programmable fault function <i>3001</i> , <i>3022</i>)	Analog input AI2 signal has fallen below limit defined by parameter <i>3022 AI2 FAULT LIMIT</i> .	Check fault function parameter settings. Check for proper analog control signal levels. Check connections.

CODE	FAULT	CAUSE	WHAT TO DO
0009	MOT OVERTEMP (4310) 0305 bit 8 (programmable fault function 0305...3009 / 3504)	Motor temperature is too high (or appears to be too high) due to excessive load, insufficient motor power, inadequate cooling or incorrect start-up data.	Check motor ratings, load and cooling. Check start-up data. Check fault function parameters.
		Measured motor temperature has exceeded fault limit set by parameter 3504 <i>FAULT LIMIT</i> .	Check value of fault limit. Check that actual number of sensors corresponds to value set by parameter 3501 <i>SENSOR TYPE</i> . Let motor cool down. Ensure proper motor cooling: Check cooling fan, clean cooling surfaces, etc.
0010	PANEL LOSS (5300) 0305 bit 9 (programmable fault function 3002)	Control panel selected as active control location for drive has ceased communicating.	Check panel connection. Check fault function parameters. Check control panel connector. Refit control panel in mounting platform. If drive is in external control mode (REM) and is set to accept start/stop, direction commands or references via control panel: Check <i>Group 10: Start/Stop/Dir</i> and <i>Group 11: Reference select</i> settings.
0012	MOTOR STALL (7121) 0305 bit 11 (programmable fault function 3010...3012)	Motor is operating in stall region due to eg excessive load or insufficient motor power.	Check motor load and drive ratings. Check fault function parameters.
0014	EXT FAULT 1 (9000) 0305 bit 13 (programmable fault function 3003)	External fault 1	Check external devices for faults. Check parameter 3003 <i>EXTERNAL FAULT 1</i> setting.
0015	EXT FAULT 2 (9001) 0305 bit 14 (programmable fault function 3004)	External fault 2	Check external devices for faults. Check parameter 3004 <i>EXTERNAL FAULT 2</i> setting.
0016	EARTH FAULT (2330) 0305 bit 15 (programmable fault function 3017)	Drive has detected a ground fault in motor or motor cable.	Check motor. Check fault function parameters. Check motor cable. Motor cable length must not exceed maximum specifications. See section <i>Motor connection data</i> on page 397.

CODE	FAULT	CAUSE	WHAT TO DO
0018	THERM FAIL (5210) <i>0306</i> bit 1	Drive internal fault. Thermistor used for drive internal temperature measurement is open or short-circuited.	Contact your local ABB representative.
0021	CURR MEAS (2211) <i>0306</i> bit 4	Drive internal fault. Current measurement is out of range.	Contact your local ABB representative.
0022	SUPPLY PHASE (3130) <i>0306</i> bit 5	Intermediate circuit DC voltage is oscillating due to missing input power line phase or blown fuse. Trip occurs when DC voltage ripple exceeds 14% of nominal DC voltage.	Check input power line fuses. Check for input power supply imbalance. Check fault function parameters.
0024	OVERSPEED (7310) <i>0306</i> bit 7	Motor is turning faster than highest allowed speed due to incorrectly set minimum/maximum speed. Operating range limits are set by parameters <i>2007 MINIMUM FO</i> and <i>2008 MAXIMUM FO</i> .	Check minimum/maximum frequency settings. Check adequacy of motor braking torque.
0026	DRIVE ID (5400) <i>0306</i> bit 9	Internal drive ID fault	Contact your local ABB representative.
0027	CONFIG FILE (630F) <i>0306</i> bit 10	Internal configuration file error	Contact your local ABB representative.
0028	SERIAL 1 ERR (7510) <i>0306</i> bit 11 (programmable fault function <i>3018</i> , <i>3019</i>)	Fieldbus communication break	Check status of fieldbus communication. See chapter <i>Fieldbus control</i> on page <i>285</i> . Check fault function parameter settings. Check connections. Check if master can communicate.
0029	EFB CON FILE (6306) <i>0306</i> bit 12	Configuration file reading error	Contact your local ABB representative.
0030	FORCE TRIP (FF90) <i>0306</i> bit 13	Trip command received from fieldbus	See appropriate communication module manual.

CODE	FAULT	CAUSE	WHAT TO DO
0031	EFB 1 (FF92) 0307 bit 0	Error from the embedded fieldbus (EFB) protocol application. The meaning is protocol dependent.	See chapter <i>Fieldbus control</i> on page 285.
0032	EFB 2 (FF93) 0307 bit 1		
0033	EFB 3 (FF94) 0307 bit 2		
0034	MOTOR PHASE (FF56) 0306 bit 14	Motor circuit fault due to missing motor phase or motor thermistor relay (used in motor temperature measurement) fault.	Check motor and motor cable. Check motor thermistor relay (if used).
0035	OUTP WIRING (FF95) 0306 bit 15 (programmable fault function 3023)	Incorrect input power and motor cable connection (ie input power cable is connected to drive motor connection). The fault can be erroneously declared if the input power is a delta grounded system and the motor cable capacitance is large. This fault can be disabled using parameter 3023 <i>WIRING FAULT</i> .	Check input power connections. Check fault function parameters.
0036	INCOMPATIBLE SW (630F) 0307 bit 3	Loaded software is not compatible.	Contact your local ABB representative.
0038	USER LOAD CURVE (FF6B) 0307 bit 4	Condition defined by 3701 <i>USER LOAD C MODE</i> has been valid longer than the time set by 3703 <i>USER LOAD C TIME</i> .	See parameter <i>Group 37: User load curve</i> .
0039	UNKNOWN EXTENSION (7086) 0307 bit 5	Option module not supported by the drive firmware is connected to the drive.	Check connections.
0040	INLET VERY LOW (8A81) 0307 bit 6	Pressure at pump/fan inlet too low	Check for a closed valve on the inlet side of the pump/fan. Check piping for leaks. See parameter <i>Group 44: Pump protection</i> .

CODE	FAULT	CAUSE	WHAT TO DO
0041	OUTLET VERY HIGH (8A83) <i>0307</i> bit 7	Pressure at pump/fan outlet too high	Check piping for blocks. See parameter <i>Group 44: Pump protection</i> .
0042	INLET LOW (8A80) <i>0307</i> bit 8	Pressure at pump/fan inlet too low	Check for a closed valve on the inlet side of the pump/fan. Check piping for leaks. See parameter <i>Group 44: Pump protection</i> .
0043	OUTLET HIGH (8A82) <i>0307</i> bit 9	Pressure at pump/fan outlet too high	Check piping for blocks. See parameter <i>Group 44: Pump protection</i> .
0101	SERF CORRUPT (FF55) <i>0307</i> bit 14	Drive internal error	Write down fault code and contact your local ABB representative.
0103	SERF MACRO (FF55) <i>0307</i> bit 14		
0201	DSP T1 OVERLOAD (6100) <i>0307</i> bit 13		
0202	DSP T2 OVERLOAD (6100) <i>0307</i> bit 13		
0203	DSP T3 OVERLOAD (6100) <i>0307</i> bit 13		
0204	DSP STACK ERROR (6100) <i>0307</i> bit 12		
0206	CB ID ERROR (5000) <i>0307</i> bit 11		
1000	PAR HZRPM (6320) <i>0307</i> bit 15	Incorrect frequency limit parameter setting	Check parameter settings. Check that following applies: <ul style="list-style-type: none"> <i>2007 MINIMUM FO</i> < <i>2008 MAXIMUM FO</i> <i>2007 MINIMUM FO / 9907 MOTOR NOM FREQ</i> and <i>2008 MAXIMUM FO / 9907 MOTOR NOM FREQ</i> are within range.

CODE	FAULT	CAUSE	WHAT TO DO
1001	PAR PFC REF NEG (6320) 0307 bit 15	Incorrect PFA parameters	Check parameter <i>Group 81: PFA control</i> settings. Check that following applies: <ul style="list-style-type: none"> • 2007 MINIMUM FO > 0 when 8123 is ACTIVE or SPFC ACTIVE.
1003	PAR AI SCALE (6320) 0307 bit 15	Incorrect analog input AI signal scaling	Check parameter <i>Group 13: Analogue inputs</i> settings. Check that following applies: <ul style="list-style-type: none"> • 1301 MINIMUM AI1 < 1302 MAXIMUM AI1 • 1304 MINIMUM AI2 < 1305 MAXIMUM AI2.
1004	PAR AO SCALE (6320) 0307 bit 15	Incorrect analog output AO signal scaling	Check parameter <i>Group 15: Analogue outputs</i> settings. Check that following applies: <ul style="list-style-type: none"> • 1504 MINIMUM AO1 < 1505 MAXIMUM AO1.
1005	PAR PCU 2 (6320) 0307 bit 15	Incorrect motor nominal power setting	Check parameter 9909 setting. Following must apply: <ul style="list-style-type: none"> • $1.1 < (9906 \text{ MOTOR NOM CURR} * 9905 \text{ MOTOR NOM VOLT} * 1.73 / P_N) < 3.0$ where $P_N = 1000 * 9909 \text{ MOTOR NOM POWER}$ (if units are in kW) or $P_N = 746 * 9909 \text{ MOTOR NOM POWER}$ (if units are in hp).
1006	PAR EXT RO (6320) 0307 bit 15	Incorrect extension relay output parameters.	Check parameter settings. Check that following applies: <ul style="list-style-type: none"> • Relay Output Extension Module MREL-0 is connected to the drive. • 1402...1403 RELAY OUTPUT 2...RELAY OUTPUT 3 and 1410 RELAY OUTPUT 4 have non-zero values. <p>See <i>MREL-01 Relay Output Extension Module User's Manual</i> (3AUA0000035974 [English]).</p>
1007	PAR FBUSMISS (6320) 0307 bit 15	Fieldbus control has not been activated.	Check fieldbus parameter settings.
1009	PAR PCU 1 (6320) 0307 bit 15	Incorrect motor nominal speed/frequency setting	Check parameter settings. Following must apply: <ul style="list-style-type: none"> • $1 < (60 * 9907 \text{ MOTOR NOM FREQ} / 9908 \text{ MOTOR NOM SPEED}) < 16$ • $0.8 < 9908 \text{ MOTOR NOM SPEED} / (120 * 9907 \text{ MOTOR NOM FREQ} / \text{Motor poles}) < 0.992$

CODE	FAULT	CAUSE	WHAT TO DO
1012	PAR PFA IO 1 (6320) <i>0307</i> bit 15	I/O configuration for PFA not complete	Check parameter settings. Following must apply: <ul style="list-style-type: none"> • There are enough relays parameterized for PFA. • No conflict exists between parameter <i>Group 14: Relay outputs</i>, parameter <i>8117 NR OF AUX MOT</i> and parameter <i>8118 AUTOCHNG INTERV.</i>
1013	PAR PFC IO 2 (6320) <i>0307</i> bit 15	I/O configuration for PFA not complete	Check parameter settings. Following must apply: <ul style="list-style-type: none"> • The actual number of PFA motors (parameter <i>8127 MOTORS</i>) matches the PFA motors in parameter <i>Group 14: Relay outputs</i> and parameter <i>8118 AUTOCHNG INTERV.</i>
1014	PAR PFC IO 3 (6320) <i>0307</i> bit 15	I/O configuration for PFA not complete. The drive is unable to allocate a digital input (interlock) for each PFA motor.	See parameters <i>8120 INTERLOCKS</i> and <i>8127 MOTORS.</i>
1015	PAR CUSTOM U/F (6320) <i>0307</i> bit 15	Incorrect voltage to frequency (U/f) ratio voltage setting.	Check parameter <i>2610 USER DEFINED U1...2617 USER DEFINED F4</i> settings.
1017	PAR SETUP 1 (6320) <i>0307</i> bit 15	It is not allowed to use frequency input signal and frequency output signal simultaneously.	Disable frequency output or frequency input: <ul style="list-style-type: none"> • change transistor output to digital mode (value of parameter <i>1804 TO MODE = DIGITAL</i>), or • change frequency input selection to other value in parameters <i>Group 11: Reference select</i>, <i>Group 40: Process PID set 1</i>, <i>Group 41: Process PID set 2</i> and <i>Group 42: Ext / Trim PID.</i>
1026	PAR USER LOAD C (6320) <i>0307</i> bit 15	Incorrect user load curve parameter setting	Check parameter settings. Following must apply: <ul style="list-style-type: none"> • <i>3704 LOAD FREQ 1</i> ≤ • <i>3707 LOAD FREQ 2</i> ≤ • <i>3710 LOAD FREQ 3</i> ≤ • <i>3713 LOAD FREQ 4</i> ≤ • <i>3716 LOAD FREQ 5</i> ≤ • <i>3705 LOAD TORQ LOW 1</i> < • <i>3706 LOAD TORQ HIGH 1</i> < • <i>3708 LOAD TORQ LOW 2</i> < • <i>3709 LOAD TORQ HIGH 2</i> < • <i>3711 LOAD TORQ LOW 3</i> < • <i>3712 LOAD TORQ HIGH 3</i> < • <i>3714 LOAD TORQ LOW 4</i> < • <i>3715 LOAD TORQ HIGH 4</i> < • <i>3717 LOAD TORQ LOW 5</i> < • <i>3718 LOAD TORQ HIGH 5.</i>

Embedded fieldbus faults

Embedded fieldbus faults can be traced by monitoring group *Group 53: EFB protocol* parameters. See also fault/alarm *SERIAL 1 ERR*.

■ No master device

If there is no master device on line, parameter *5306 EFB OK MESSAGES* and *5307 EFB CRC ERRORS* values remain unchanged.

What to do:

- Check that the network master is connected and properly configured.
- Check the cable connection.

■ Same device address

If two or more devices have the same address, parameter *5307 EFB CRC ERRORS* value increases with every read/write command.

What to do:

- Check the device addresses. No two devices on line may have the same address.

■ Incorrect wiring

If the communication wires are swapped (terminal A on one device is connected to terminal B on another device), parameter *5306 EFB OK MESSAGES* value remains unchanged and parameter *5307 EFB CRC ERRORS* increases.

What to do:

- Check the RS-232/485 interface connection.
-



Maintenance and hardware diagnostics

Contents of this chapter

The chapter contains preventive maintenance instructions and LED indicator descriptions.

Maintenance intervals

If installed in an appropriate environment, the drive requires very little maintenance. The table lists the routine maintenance intervals recommended by ABB Drives.

Maintenance	Interval	Instruction
Reforming of capacitors	Every year when stored	See Capacitors on page 382.
Check of dustiness, corrosion and temperature	Every year	
Replacement of the cooling fan (frame sizes R1...R4)	Every three years	See Cooling fan on page 380.
Check and tightening of the power terminals	Every six years	See Power connections on page 382.
Replacement of the battery in the Assistant Control Panel	Every ten years	See Changing the battery in the Assistant control panel on page 382.

Consult your local ABB Service representative for more details on the maintenance. On the Internet, go to <http://www.abb.com/drives> and select *Drive Services – Maintenance and Field Services*.

Cooling fan

The life span of the drive's cooling fan depends on the drive usage and ambient temperature. Automatic fan On/Off control increases the life span. See parameter [1612 FAN CONTROL](#).

When the Assistant control panel is in use, the Notice Handler Assistant informs when the definable value of the operating hour counter is reached (see parameter [2901 COOLING FAN TRIG](#)). This information can also be passed to the relay output (see parameter [1401 RELAY OUTPUT 1](#)) regardless of the used panel type.

Fan failure can be predicted by the increasing noise from the fan bearings. If the drive is operated in a critical part of a process, fan replacement is recommended once these symptoms start appearing. Replacement fans are available from ABB Drives. Do not use other than ABB specified spare parts.

■ Replacing the cooling fan (frame sizes R1...R4)

Only frame sizes R1...R4 include a fan; frame size R0 has natural cooling.

 **WARNING!** Obey the safety instructions. See chapter [Safety](#) on page [15](#). If you ignore the safety instructions, injury or death can occur. If you are not a qualified electrician, do not do electrical work.

1. Stop the drive and disconnect it from the power line. Wait for five minutes to let the drive DC capacitors discharge. Make sure that there is no voltage present. Measure by a multimeter (impedance at least 1 Mohm) the voltage between the input terminals and ground and the output terminals and ground.
2. Remove the hood if the drive has the NEMA 1 option.
3. Lever the fan holder off the drive frame with, for example, a screwdriver.
4. Free the fan cable from the clip in the drive frame.
5. Lift the holder from the hinges.

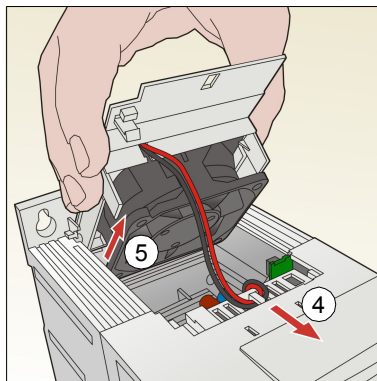
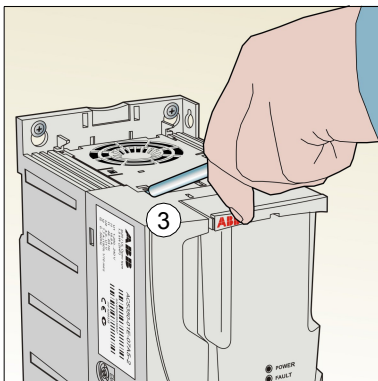

6. Disconnect the fan cable. The figure below on the right shows the location of the fan cable connector in frame size R2. The inside views in different frame sizes are not identical, but the fan cable connector is always on the control board that is against the front of the drive.

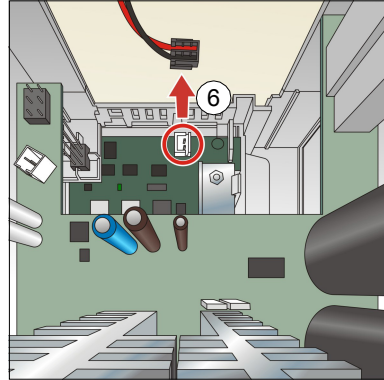
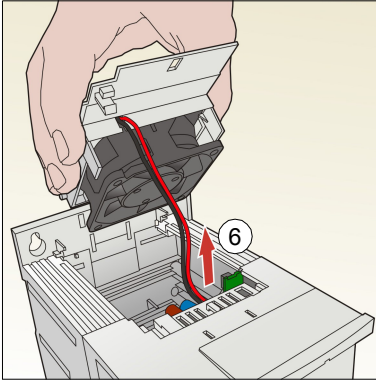

7. Free the fan cable from the clip in the fan holder.
8. Remove the fan from the holder.

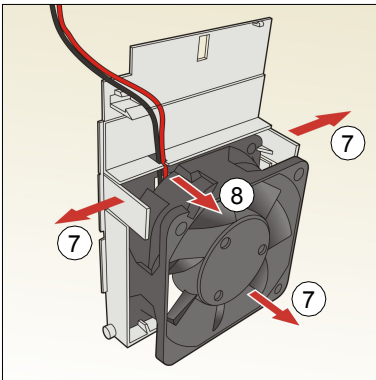

9. Install the new fan in reverse order.
10. Restore power.

Capacitors

■ Reforming the capacitors

The capacitors must be reformed if the drive has been stored for a year. See section *Type designation label* on page 26 for how to find out the manufacturing time from the serial number. For information on reforming the capacitors, refer to *Guide for Capacitor Reforming in ACS50, ACS55, ACS150, ACS310, ACS320, ACS350, ACS550 and ACH550* (3AFE68735190 [English]), available on the Internet (go to <http://www.abb.com> and enter the code in the Search field).

Power connections



WARNING! Obey the safety instructions. See chapter *Safety* on page 15. If you ignore the safety instructions, injury or death can occur. If you are not a qualified electrician, do not do electrical work.

1. Stop the drive and disconnect it from the power line. Wait for five minutes to let the drive DC capacitors discharge. Make sure that there is no voltage present. Measure by a multimeter (impedance at least 1 Mohm) the voltage between the input terminals and ground and the output terminals and ground.
2. Check the tightness of the power cable connections. Use the tightening torques given in section *Terminal and lead-through data for the power cables* on page 396.
3. Restore power.

Control panel

■ Cleaning the control panel

Use a soft damp cloth to clean the control panel. Avoid harsh cleaners which could scratch the display window.

■ Changing the battery in the Assistant control panel

A battery is only used in Assistant control panels that have the clock function available and enabled. The battery keeps the clock operating in memory during power interruptions.

The expected life for the battery is greater than ten years. To remove the battery, use a coin to rotate the battery holder on the back of the control panel. Replace the battery with type CR2032.

Note: The battery is NOT required for any control panel or drive functions, except the clock.

LEDs

There is a green and a red LED on the front of the drive. They are visible through the panel cover but invisible if a control panel is attached to the drive. The Assistant control panel has one LED. The table below describes the LED indications.

Where	LED off	LED lit and steady		LED blinking	
On the front of the drive. If a control panel is attached to the drive, switch to remote control (otherwise a fault will be generated), and then remove the panel to be able to see the LEDs.	No power	Green	Power supply on the board OK	Green	Drive in an alarm state
		Red	Drive in a fault state. To reset the fault, press RESET from the control panel or switch off the drive power.	Red	Drive in a fault state. To reset the fault, switch off the drive power.
At the top left corner of the Assistant Control Panel	Panel has no power or no drive connection.	Green	Drive in a normal state	Green	Drive in an alarm state
		Red	Drive in a fault state. To reset the fault, press RESET from the control panel or switch off the drive power.	Red	-

15

Technical data

Contents of this chapter

The chapter contains the technical specifications of the drive, for example, ratings, sizes and technical requirements as well as provisions for fulfilling the requirements for CE and other marks.

Ratings

Note: When choke is not used, input current is effected by supply network and impedance.

Use the table in *Fuses and alternate short-circuit protection* (page 390) to correctly size the input cabling as well as input fuses or MMP for branch circuit protection. Sizing will be determined by the actual input current which is dependent on the input line voltage and the input choke selection and rated motor current. If motor rated current is below I_{2N} , I_{1N} is reduced relatively.

Type code	Input				Output						Frame size
	without choke or reactor		with choke or 5% reactor		$I_{LD}^{2)}$	I_{2N}	$I_{2N}^{(480V)}$	$I_{2max}^{3)}$	P_N		
ACS320-	I_{1N}	$I_{1N}^{(480V)}$	I_{1N}	$I_{1N}^{(480V)}$							A
$x = E/U^1)$	A	A	A	A	A	A	A	A	kW	hp	
1-phase supply voltage 200...240 V units (Confirm output ratings meet motor requirements)											
01x-02A4-2	6.1	-	4.5	-	2.3	2.4	-	4.0	0.37	0.5	R0
01x-04A7-2	11	-	8.1	-	4.5	4.7	-	7.9	0.75	1	R1
01x-06A7-2	16	-	11	-	6.5	6.7	-	11.4	1.1	1.5	R1
01x-07A5-2	17	-	12	-	7.2	7.5	-	12.6	1.5	2	R2
01x-09A8-2	21	-	15	-	9.4	9.8	-	16.5	2.2	3	R2
3-phase supply voltage 200...240 V units											
03x-02A6-2	4.7	-	2.6	-	2.4	2.6	-	4.2	0.37	0.5	R0
03x-03A9-2	6.7	-	3.6	-	3.5	3.9	-	6.1	0.55	0.75	R0
03x-05A2-2	8.4	-	4.8	-	4.7	5.2	-	8.2	0.75	1	R1
03x-07A4-2	13	-	7.2	-	6.7	7.4	-	11.7	1.1	1.5	R1
03x-08A3-2	13	-	8.2	-	7.5	8.3	-	13.1	1.5	2	R1
03x-10A8-2	16	-	11	-	9.8	10.8	-	17.2	2.2	3	R2
03x-14A6-2	24	-	14	-	13.3	14.6	-	23.3	3	3	R2
03x-19A4-2	27	-	18	-	17.6	19.4	-	30.8	4	5	R2
03x-26A8-2	45	-	27	-	24.4	26.8	-	42.7	5.5	7.5	R3
03x-34A1-2	55	-	34	-	31	34.1	-	54.3	7.5	10	R4
03x-50A8-2	76	-	47	-	46.2	50.8	-	80.9	11	15	R4
3-phase supply voltage 380...480 V units											
03x-01A2-4	2.2	1.8	1.1	0.9	1.1	1.2	1.2	2.1	0.37	0.5	R0
03x-01A9-4	3.6	3	1.8	1.5	1.7	1.9	1.9	3.3	0.55	0.75	R0
03x-02A4-4	4.1	3.4	2.3	1.9	2.2	2.4	2.4	4.2	0.75	1	R1
03x-03A3-4	6	5	3.1	2.6	3.0	3.3	3.3	5.8	1.1	1.5	R1
03x-04A1-4	6.9	5.8	3.5	2.9	3.7	4.1	4.1	7.2	1.5	2	R1
03x-05A6-4	9.6	8	4.8	4	5.1	5.6	5.6	9.8	2.2	3	R1
03x-07A3-4	12	9.7	6.1	5.1	6.6	7.3	7.3	12.8	3	3	R1
03x-08A8-4	14	11	7.7	6.4	8.0	8.8	8.8	15.4	4	5	R1

Type code	Input				Output						Frame size
	without choke or reactor		with choke or 5% reactor		$I_{LD}^{2)}$	I_{2N}	$I_{2N}^{(480\text{ V})}$	$I_{2max}^{3)}$	P_N		
ACS320-	I_{1N}	$I_{1N}^{(480\text{ V})}$	I_{1N}	$I_{1N}^{(480\text{ V})}$							A
$x = E/U^{1)}$	A	A	A	A	A	A	A	A	kW	hp	
03x-12A5-4	19	16	11	9.5	11.4	12.5	12.5	21.9	5.5	7.5	R3
03x-15A6-4	22	18	12	10	14.2	15.6	15.6	27.3	7.5	10	R3
03x-23A1-4	31	26	18	15	21.0	23.1	23.1	40.4	11	15	R3
03x-31A0-4	52	43	25	20	28.2	31	31	54.3	15	20	R4
03x-38A0-4	61	51	32	26	34.5	38	38	66.5	18.5	25	R4
03x-44A0-4	67	56	38	32	40.0	44	44	77.0	22	30	R4

¹⁾ E = EMC filter connected (metal EMC filter screw installed),
 U = EMC filter disconnected (plastic EMC filter screw installed), default.

²⁾ Overloadability for one minute every ten minutes.

³⁾ Instantaneous peak current for two seconds once every ten minutes

00578903.xls K

Definitions

Input

I_{1N} continuous RMS input current (for dimensioning cables and fuses) with I_{2N} motor current at rated speed and power. If motor rated current is below I_{2N} , I_{1N} is reduced relatively.

$I_{1N}^{(480\text{ V})}$ continuous RMS input current (for dimensioning cables, fuses, and MMPs) for drives with 480 V with I_{2N} motor current at rated speed and power. If motor rated current is below I_{2N} , I_{1N} is reduced relatively.

Output

I_{LD} continuous output current at max ambient temperature of +50 °C (122 °F). 10% overloadability for one minute every ten minutes.

I_{2N} maximum continuous output current at ambient temperature of +40 °C (104 °F). No overloadability, derating 1% for every additional 1 °C up to 50 °C (122 °F).

$I_{2N}^{(480\text{ V})}$ maximum continuous output current at ambient temperature of +40 °C (104 °F) for drives with 480 V. No overloadability, derating 1% for every additional 1 °C up to 50 °C (122 °F).

I_{2max} maximum instantaneous output current. Available for two seconds every ten minutes at start-up, or as long as allowed by the drive temperature.

P_N typical motor power. The kilowatt ratings apply to most IEC 4-pole motors. The horsepower ratings apply to most NEMA 4-pole motors. Drive should be selected based on motor current relative to loading capacity (I_{LD} or I_{2N}).

R0...R4 ACS320 is manufactured in frame sizes R0...R4. Some instructions and other information that only concern certain frame sizes are marked with the symbol of the frame size (R0...R4).

■ Sizing

Drive sizing is based on the rated motor current and power. To achieve the rated motor power given in the table, the rated current of the drive must be higher than or equal to the rated motor current. The rated power of the drive must also be higher than or equal to compared to the rated motor power. The power ratings are the same regardless of the supply voltage within one voltage range.

In multimotor systems, the drive output current rating I_{LD} must be equal to or greater than the calculated sum of the input currents of all motors.

Note:

- The maximum allowed motor shaft power is limited to $1.5 \cdot P_N$. If the limit is exceeded, motor torque and current are automatically restricted. The function protects the input bridge of the drive against overload.
- The ratings apply at ambient temperature of 40 °C (104 °F) for I_{2N} and 50 °C (122 °F) for I_{LD} .

■ Derating

The load capacity decreases if the installation site ambient temperature exceeds 40 °C (104 °F) or if the altitude exceeds 1000 meters (3300 ft).

Temperature derating

In the temperature range +40 °C...+50 °C (+104 °F...+122 °F), the rated output current is decreased by 1% for every additional 1 °C (1.8 °F). The output current is calculated by multiplying the current given in the rating table by the derating factor.

Example: If the ambient temperature is 50 °C (+122 °F), the derating factor is $100\% - 1 \frac{\%}{\text{°C}} \cdot 10 \text{ °C} = 90\%$ or 0.90. The output current is then $0.90 \cdot I_{2N}$ (where I_{2N} = continuous output at 40 °C, 0% overload)

Altitude derating

In altitudes 1000...2000 m (3300...6600 ft) above sea level, the derating is 1% for every 100 m (330 ft).

Switching frequency derating

Derate according to the switching frequency used (see parameter [2606 SWITCHING FREQ](#)) as follows:

Switching frequency	Drive voltage rating	
	$U_N = 200...240\text{ V}$	$U_N = 380...480\text{ V}$
4 kHz	No derating	No derating
8 kHz	Derate I_{2N} to 90%.	Derate I_{2N} to 75% for R0 or to 80% for R1...R4.
12 kHz	Derate I_{2N} to 80%.	Derate I_{2N} to 50% for R0 or to 65% for R1...R4 and derate maximum ambient temperature to 30 °C (86 °F).
16 kHz	Derate I_{2N} to 75%.	Derate I_{2N} to 50% and derate maximum ambient temperature to 30 °C (86 °F).

I_{2N} = continuous output at 40 °C, 0% overload.

Fuses and alternate short-circuit protection

Fuses

The rated fuse currents given in the table are the maximums for the mentioned fuse types. If smaller fuse ratings are used, check that the fuse RMS current rating is larger than the rated I_{1N} current given in the [Ratings](#) table on page [386](#). If 150% of output power is needed, multiply current I_{1N} by 1.5. See also section [Selecting the power cables](#) on page [37](#).

The UL listed fuses in the table are the required branch circuit protection. Fuses are to be provided as part of the installation.

Notes:

1. Fuses are not included in the purchased drive and must be provided by others.
2. Fuses with higher current rating than specified must not be used.
3. Fuses with lower current rating than specified may be used if they are of the same class and voltage rating. It is the user's responsibility to verify that lower current rated fuses are compliant with local regulations and appropriate for the application.
4. Drive fuses must be used to maintain the drive UL listing. Additional protection can be used. Refer to local codes and regulations.

Alternate short-circuit protection

In accordance with the National Electrical Code (NEC), the following ABB type E manual motor protectors can be used as an alternate to the recommended fuses as a means of branch circuit protection:

- MS132-x.x and S1-M3-25
- MS495-xx or MS495-xxE and SK4-11 & DX49
- MS165-xx.

When the correct ABB type E manual motor protector is selected from the table and used for branch circuit protection, the drive is suitable for use in a circuit capable of delivering not more than 65 kA RMS symmetrical amperes at the drive maximum rated voltage. See the appropriate ratings in the following table.

IP20 open type and IP21 UL type 1 ACS320 can use ABB type E manual motor protectors for branch circuit protection. See the MMP rating table for the minimum enclosure volume of IP20 open type ACS320 mounted in an enclosure.

Fuses and MMPs

Type	Fuses			MMPs				
ACS320-	gG	UL Class T or CC (600 V)		Frame	I_{1N}	MMP Type E ^{6) 7)}	Min. Encl. Vol. ⁵⁾	
x = E/U ¹⁾	A	min A ²⁾	max A		A		dm ³	in ³
1-phase $U_N = 200...240$ V (200, 208, 220, 230, 240 V)								
01x-02A4-2	10	6	10	R0	6.1	MS132-6.3 & S1-M3-25 ⁴⁾	18.9	1152
01x-04A7-2	16	10	20	R1	11	MS165-16 ³⁾	18.9	1152
01x-06A7-2	16/20*	15	25	R1	16	MS165-20 ³⁾	18.9	1152
01x-07A5-2	20/25*	15	30	R2	17	MS165-20 ³⁾	-	-
01x-09A8-2	25/35*	15	35	R2	21	MS165-25 ³⁾	-	-
3-phase $U_N = 200...240$ V (200, 208, 220, 230, 240 V)								
03x-02A6-2	10	3	10	R0	4.7	MS132-6.3 & S1-M3-25 ⁴⁾	18.9	1152
03x-03A9-2	10	6	10	R0	6.7	MS132-10 & S1-M3-25 ⁴⁾	18.9	1152
03x-05A2-2	10	6	15	R1	8.4	MS132-10 & S1-M3-25 ⁴⁾	18.9	1152
03x-07A4-2	16	10	15	R1	13	MS165-16 ³⁾	18.9	1152
03x-08A3-2	16	10	15	R1	13	MS165-16 ³⁾	18.9	1152
03x-10A8-2	16	15	20	R2	16	MS165-20 ³⁾	-	-
03x-14A6-2	25	15	30	R2	24	MS165-25 ³⁾	-	-
03x-19A4-2	25	20	35	R2	27	MS165-32 ³⁾	-	-
03x-26A8-2	63	30	60	R3	45	MS165-54 ³⁾	-	-
03x-34A1-2	80	35	80	R4	55	MS165-65 ³⁾	-	-
03x-50A8-2	100	50	100	R4	76	MS495-90E ³⁾	-	-
3-phase $U_N = 380...480$ V (380, 400, 415 V) (MMP ratings for 480Y/277V only)⁸⁾								
03x-01A2-4	10	2	10	R0	2.2	MS132-2.5 & S1-M3-25 ⁴⁾	18.9	1152
03x-01A9-4	10	2	10	R0	3.6	MS132-4.0 & S1-M3-25 ⁴⁾	18.9	1152
03x-02A4-4	10	3	10	R1	4.1	MS132-6.3 & S1-M3-25 ⁴⁾	18.9	1152
03x-03A3-4	10	3	10	R1	6	MS132-6.3 & S1-M3-25 ⁴⁾	18.9	1152
03x-04A1-4	16	6	15	R1	6.9	MS132-10 & S1-M3-25 ⁴⁾	18.9	1152
03x-05A6-4	16	6	15	R1	9.6	MS132-10 & S1-M3-25 ⁴⁾	18.9	1152
03x-07A3-4	16	10	20	R1	12	MS165-16 ³⁾	18.9	1152
03x-08A8-4	20	10	25	R1	14	MS165-16 ³⁾	18.9	1152
03x-12A5-4	25	15	30	R3	19	MS165-20 ³⁾	-	-
03x-15A6-4	35	15	35	R3	22	MS165-25 ³⁾	-	-
03x-23A1-4	50	20	50	R3	31	MS165-42 ³⁾	-	-
03x-31A0-4	80	25	80	R4	52	MS165-65 ³⁾	-	-
03x-38A0-4	100	35	100	R4	61	MS165-65 ³⁾	-	-
03x-44A0-4	100	40	100	R4	67	MS495-75E ³⁾	-	-
3-phase $U_N = 380...480$ V (440, 460, 480 V) (MMP ratings for 480Y/277V only)⁸⁾								
03x-01A2-4	10	2	10	R0	1.8	MS132-2.5 & S1-M3-25 ⁴⁾	18.9	1152
03x-01A9-4	10	2	10	R0	3	MS132-4.0 & S1-M3-25 ⁴⁾	18.9	1152
03x-02A4-4	10	3	10	R1	3.4	MS132-6.3 & S1-M3-25 ⁴⁾	18.9	1152
03x-03A3-4	10	3	10	R1	5	MS132-6.3 & S1-M3-25 ⁴⁾	18.9	1152
03x-04A1-4	16	6	15	R1	5.8	MS132-10 & S1-M3-25 ⁴⁾	18.9	1152
03x-05A6-4	16	6	15	R1	8	MS132-10 & S1-M3-25 ⁴⁾	18.9	1152
03x-07A3-4	16	10	20	R1	9.7	MS132-10 & S1-M3-25 ⁴⁾	18.9	1152
03x-08A8-4	20	10	25	R1	11	MS165-16 ³⁾	18.9	1152
03x-12A5-4	25	15	30	R3	16	MS165-20 ³⁾	-	-
03x-15A6-4	35	15	35	R3	18	MS165-20 ³⁾	-	-

Type	Fuses			MMPs				
ACS320-	gG	UL Class T or CC (600 V)		Frame	I_{1N}	MMP Type E ^{6) 7)}	Min. Encl. Vol. ⁵⁾	
$x = E/U^{1)}$	A	min A ²⁾	max A		A		dm ³	in ³
03x-23A1-4	50	20	50	R3	26	MS165-32 ³⁾	-	-
03x-31A0-4	80	25	80	R4	43	MS165-54 ³⁾	-	-
03x-38A0-4	100	35	100	R4	51	MS165-65 ³⁾	-	-
03x-44A0-4	100	40	100	R4	56	MS165-65 ³⁾	-	-

00578903.xls.K

* If 150% output is needed, use the larger fuse alternative.

¹⁾ E = EMC filter connected (metal EMC filter screw installed).

U = EMC filter disconnected (plastic EMC filter screw installed), U.S parameterization

²⁾ Minimum fuse size can be used with input choke according to table in Rating section

³⁾ Trip class 10; integral trip indication; does not require additional line-side feeder terminal.

⁴⁾ Require additional line-side feeder terminal S1-M3-25 with the manual motor protector, to meet Type E self-protection class.

⁵⁾ Minimum enclosure volume is specified in the UL listing for R0 & R1 frame drives when applied with the ABB Type E MMP shown in the table. ABB IP20 micro drives are intended to be mounted in an enclosure unless a NEMA 1 kit is added. For all drives, the enclosure must be sized to accommodate the specific thermal considerations of the application as well as provide free space for cooling. See section, [Free space requirements](#) on page 394.

⁶⁾ All manual motor protectors listed are Type E self-protected up to 65 kA. To use these manual protectors for branch circuit protection, the protectors must be UL listed Type E manual motor protectors. Else, it can be used only as an At Motor Disconnect. At Motor Disconnect is a disconnect just after the motor on the load side of the panel. For more information, see *Manual motor starters, North American applications* (2CDC131085M0201 [English]) application handbook.

⁷⁾ To avoid nuisance tripping, manual motor protectors might require adjustment of the trip limit from the factory setting to drive input Amps or above. If the nuisance tripping occurs with the manual motor protector at maximum current trip level, select the next size MMP. (MS132-10 is the highest size in the MS132 frame size to meet Type E at 65kA; next size up is MS165-16).

⁸⁾ 480Y/277V delta systems only. Short-circuit protective devices with slash voltage ratings (e.g. 480Y/277 VAC) can be applied only in solidly grounded networks where the voltage from line-to-ground does not exceed the lowest of the two ratings (e.g. 277 V AC), and the voltage from line-to-line does not exceed the highest of the ratings (e.g. 480 V AC). The lower rating represents the device's interrupting capability per pole.

■ Size of copper conductor in cabling

Cable dimensioning for rated currents (I_{1N}) is shown in the table below.

Type	Size of copper conductor in cabling					
	Supply (U1, V1, W1)		Motor (U2, V2, W2)		PE	
	x = E/U ¹⁾	mm ²	AWG	mm ²	AWG	mm ²
1-phase						
01x-02A4-2	2.5	14	0.75	18	2.5	14
01x-04A7-2	2.5	14	0.75	18	2.5	14
01x-06A7-2	2.5	10	1.5	14	2.5	10
01x-07A5-2	2.5	10	1.5	14	2.5	10
01x-09A8-2	6	10	2.5	12	6	10
3-phase						
03x-02A6-2	2.5	14	1.5	14	2.5	14
03x-03A9-2	2.5	14	1.5	14	2.5	14
03x-05A2-2	2.5	14	1.5	14	2.5	14
03x-07A4-2	2.5	12	1.5	14	2.5	12
03x-08A3-2	2.5	12	1.5	14	2.5	12
03x-10A8-2	2.5	12	2.5	12	2.5	12
03x-14A6-2	6.0	10	6	10	6.0	10
03x-19A4-2	6.0	10	6	10	6.0	10
03x-26A8-2	10.0	8	10	8	10.0	8
03x-34A1-2	16.0	6	16	6	16.0	6
03x-50A8-2	25.0	2	25	2	16.0	4
3-phase						
03x-01A2-4	2.5	14	1.5	14	2.5	14
03x-01A9-4	2.5	14	1.5	14	2.5	14
03x-02A4-4	2.5	14	1.5	14	2.5	14
03x-03A3-4	2.5	12	1.5	14	2.5	12
03x-04A1-4	2.5	12	1.5	14	2.5	12
03x-05A6-4	2.5	12	1.5	14	2.5	12
03x-07A3-4	2.5	12	1.5	14	2.5	12
03x-08A8-4	2.5	12	2.5	12	2.5	12
03x-12A5-4	6.0	10	6	10	6.0	10
03x-15A6-4	6.0	8	6	8	6.0	8
03x-23A1-4	10.0	8	10	8	10.0	8
03x-31A0-4	16.0	6	16	6	16.0	6
03x-38A0-4	25.0	4	16	4	16.0	4
03x-44A0-4	25.0	4	25	4	16.0	4

¹⁾ E = EMC filter connected (metal EMC filter screw installed),

U = EMC filter disconnected (plastic EMC filter screw installed), default configuration for the U.S.

Dimensions, weights and free space requirements

■ Dimensions and weights

Frame size	Dimensions and weights											
	IP20 (cabinet) / UL open											
	H1		H2		H3		W		D		Weight	
	mm	in	mm	in	mm	in	mm	in	mm	in	kg	lb
R0	169	6.65	202	7.95	239	9.41	70	2.76	161	6.34	1.2	2.6
R1	169	6.65	202	7.95	239	9.41	70	2.76	161	6.34	1.4	3.1
R2	169	6.65	202	7.95	239	9.41	105	4.13	165	6.50	1.8	4.0
R3	169	6.65	202	7.95	236	9.29	169	6.65	169	6.65	2.9	6.4
R4	181	7.13	202	7.95	244	9.61	260	10.24	169	6.65	5.1	11.2

00578903.xls G

Frame size	Dimensions and weights									
	IP20 / NEMA 1									
	H4		H5		W		D		Weight	
	mm	in	mm	in	mm	in	mm	in	kg	lb
R0	257	10.12	280	11.02	70	2.76	169	6.65	1.6	3.5
R1	257	10.12	280	11.02	70	2.76	169	6.65	1.8	4.0
R2	257	10.12	282	11.10	105	4.13	169	6.65	2.2	4.9
R3	260	10.24	299	11.77	169	6.65	177	6.97	3.5	7.7
R4	270	10.63	320	12.60	260	10.24	177	6.97	5.7	12.6

00578903.xls G

Symbols

IP20 (cabinet) / UL open

H1 height without fastenings and clamping plate

H2 height with fastenings, without clamping plate

H3 height with fastenings and clamping plate

IP20 / NEMA 1

H4 height with fastenings and connection box

H5 height with fastenings, connection box and hood

■ Free space requirements

Frame size	Free space required					
	Above		Below		On the sides	
	mm	in	mm	in	mm	in
R0...R4	75	3	75	3	0	0

Losses, cooling data and noise

Losses and cooling data

Frame size R0 has natural convection cooling. Frame sizes R1...R4 are provided with an internal fan. The air flow direction is from bottom to top.

The table below specifies the heat dissipation in the main circuit at nominal load and in the control circuit with minimum load (I/O and panel not in use) and maximum load (all digital inputs in the on state and the panel, fieldbus and fan in use). The total heat dissipation is the sum of the heat dissipation in the main and control circuits.

Type Code	Heat dissipation						Air flow	
	Main circuit		Control circuit					
	Rated current		Min		Max			
	W	BTU/Hr	W	BTU/Hr	W	BTU/Hr	m ³ /h	ft ³ /min
1-phase supply voltage 200 - 240 V units								
ACS320-01U-02A4-2	19	65	6.1	21	22.7	78	-	-
ACS320-01U-04A7-2	38	130	9.5	32	26.4	90	24	14
ACS320-01U-06A7-2	60	205	9.5	32	26.4	90	24	14
ACS320-01U-07A5-2	62	212	10.5	36	27.5	94	21	12
ACS320-01U-09A8-2	83	283	10.5	36	27.5	94	21	12
3-phase supply voltage 200 - 240 V units								
ACS320-03U-02A6-2	19	65	6.1	21	22.7	78	-	-
ACS320-03U-03A9-2	31	106	6.1	21	22.7	78	-	-
ACS320-03U-05A2-2	38	130	9.5	32	26.4	90	24	14
ACS320-03U-07A4-2	60	205	9.5	32	26.4	90	24	14
ACS320-03U-08A3-2	62	212	9.5	32	26.4	90	21	12
ACS320-03U-10A8-2	83	283	10.5	36	27.5	94	21	12
ACS320-03U-14A6-2	112	383	10.5	36	27.5	94	52	31
ACS320-03U-19A4-2	152	519	10.5	36	27.5	94	52	31
ACS320-03U-26A8-2	250	854	16.6	57	35.4	121	71	42
ACS320-03U-34A1-2	270	922	33.4	114	57.8	197	96	57
ACS320-03U-50A8-2	430	1469	33.4	114	57.8	197	96	57
3-phase supply voltage 380 - 480 V units								
ACS320-03U-01A2-4	11	38	6.6	23	24.4	83	-	-
ACS320-03U-01A9-4	16	55	6.6	23	24.4	83	-	-
ACS320-03U-02A4-4	21	72	9.8	33	28.7	98	13	8
ACS320-03U-03A3-4	31	106	9.8	33	28.7	98	13	8
ACS320-03U-04A1-4	40	137	9.8	33	28.7	98	13	8
ACS320-03U-05A6-4	61	208	9.8	33	28.7	98	19	11
ACS320-03U-07A3-4	74	253	14.1	48	32.7	112	24	14
ACS320-03U-08A8-4	94	321	14.1	48	32.7	112	24	14
ACS320-03U-12A5-4	130	444	12.0	41	31.2	107	52	31

Type Code	Heat dissipation						Air flow	
	Main circuit		Control circuit					
	Rated current		Min		Max			
	W	BTU/Hr	W	BTU/Hr	W	BTU/Hr	m ³ /h	ft ³ /min
ACS320-03U-15A6-4	173	591	12.0	41	31.2	107	52	31
ACS320-03U-23A1-4	266	908	16.6	57	35.4	121	71	42
ACS320-03U-31A0-4	350	1195	33.4	114	57.8	197	96	57
ACS320-03U-38A0-4	440	1503	33.4	114	57.8	197	96	57
ACS320-03U-44A0-4	530	1810	33.4	114	57.8	197	96	57

■ Noise

Frame size	Noise level
	dBA
R0	<30
R1	50...62
R2	50...62
R3	50...62
R4	<62

Terminal and lead-through data for the power cables

Frame size	Max. cable diameter for NEMA 1		U1, V1, W1, U2, V2, W2				PE			
	U1, V1, W1, U2, V2, W2		Max. terminal size flexible/rigid		Tightening torque		Max. clamp size solid or stranded		Tightening torque	
	mm	in	mm ²	AWG	N·m	lbf·in	mm ²	AWG	N·m	lbf·in
R0	16	0.63	4.0/6.0	10	0.8	7	25	3	1.2	11
R1	16	0.63	4.0/6.0	10	0.8	7	25	3	1.2	11
R2	16	0.63	4.0/6.0	10	0.8	7	25	3	1.2	11
R3	29	1.14	10.0/16.0	6	1.7	15	25	3	1.2	11
R4	35	1.38	25.0/35.0	2	2.5	22	25	3	1.2	11

Terminal and lead-through data for the control cables

Conductor size						Tightening torque	
Solid or stranded		Stranded, with ferrule without plastic sleeve		Stranded, with ferrule with plastic sleeve			
Min/Max	Min/Max	Min/Max	Min/Max	Min/Max	Min/Max	N·m	lbf·in
mm ²	AWG	mm ²	AWG	mm ²	AWG		
0.14/1.5	26/16	0.25/1.5	23/16	0.25/1.5	23/16	0.4	3.5

Electric power network specification

Voltage (U_1)	200/208/220/230/240 V AC 1-phase for 200 V AC drives 200/208/220/230/240 V AC 3-phase for 200 V AC drives 380/400/415/440/460/480 V AC 3-phase for 400 V AC drives $\pm 10\%$ variation from converter nominal voltage is allowed as default.
Short-circuit capacity	Maximum allowed prospective short-circuit current at the input power connection as defined in IEC 60439-1 is 100 kA. The drive is suitable for use in a circuit capable of delivering not more than 100 kA RMS symmetrical amperes at the drive maximum rated voltage. Note: Use appropriate fuses or MMP's to achieve 100 kA.
Frequency	50/60 Hz $\pm 5\%$, maximum rate of change 17%/s
Imbalance	Max. $\pm 3\%$ of nominal phase to phase input voltage

Motor connection data

Voltage (U_2)	0 to U_1 , 3-phase symmetrical, U_{max} at the field weakening point
Short-circuit protection (IEC 61800-5-1, UL 508C)	The motor output is short-circuit proof by IEC 61800-5-1 and UL 508C.
Frequency	0...500 Hz
Frequency resolution	0.01 Hz
Current	See section Ratings on page 386 or Definitions on page 387.
Power limit	$1.5 \cdot P_N$
Field weakening point	10...500 Hz
Switching frequency	4, 8, 12 or 16 kHz
Maximum recommended motor cable length	R0: 30 m (100 ft), R1...R4: 50 m (165 ft) With output chokes the motor cable length may be extended to 60 m (195 ft) for R0 and 100 m (330 ft) for R1...R4.

To comply with the European EMC Directive, use the cable lengths specified in the table below for 4 kHz switching frequency. The lengths are given for using the drive with the internal EMC filter or an optional external EMC filter.

4 kHz switching frequency	Internal EMC filter	Optional external EMC filter
Second environment (category C3 ¹⁾)	30 m (100 ft)	30 m (100 ft) minimum
First environment (category C2 ¹⁾)	-	30 m (100 ft)

¹⁾ See the new terms in section [Definitions](#) on page 401.

Note: Longer cables cause a motor voltage decrease which limits the available motor power. The decrease depends on the motor cable length and characteristics. Contact ABB for more information. Note that a sine filter (optional) at the drive output also causes a voltage decrease.

Control connection data

Analog inputs X1A: 2 and 5	Voltage signal, unipolar bipolar	0 (2)...10 V, $R_{in} > 312 \text{ kohm}$ -10...10 V, $R_{in} > 312 \text{ kohm}$
	Current signal, unipolar bipolar	0 (4)...20 mA, $R_{in} = 100 \text{ ohm}$ -20...20 mA, $R_{in} = 100 \text{ ohm}$
	Potentiometer reference value (X1A: 4)	10 V \pm 1%, max. 10 mA, $R < 10 \text{ kohm}$
	Resolution	0.1%
	Accuracy	\pm 1%
Analog output X1A: 7		0 (4)...20 mA, load < 500 ohm
Auxiliary voltage X1A: 9		24 V DC \pm 10%, max. 200 mA
Digital inputs X1A: 12...16 (frequency input X1A: 16)	Voltage	12...24 V DC with internal or external supply
	Type	PNP and NPN
	Frequency input Input impedance	Pulse train 0...16 kHz (X1A: 16 only) 2.4 kohm
Relay output X1B: 17...19	Type	NO + NC
	Max. switching voltage	250 V AC / 30 V DC
	Max. switching current	0.5 A / 30 V DC; 5 A / 230 V AC
	Max. continuous current	2 A RMS
Digital output X1B: 20...21	Type	Transistor output PNP
	Max. switching voltage	30 V DC
	Max. switching current	100 mA / 30 V DC, short-circuit protected
	Frequency	10 Hz ... 16 kHz
	Resolution	1 Hz
	Accuracy	0.2%
EIA-485 interface X1C: 23...26	Cable	Shielded twisted pair, impedance 100...150 ohm
	Termination	Daisy chained bus without drop out lines
	Isolation	Bus interface isolated from the drive
	Transfer rate	1.2...76.8 kbit/s
	Communication type Protocol	Serial, asynchronous, half duplex Modbus

Clearance and creepage distance

The clearance and creepage distance between I/O connections and mains circuit is 5.5 mm, which guarantees safety insulation of overvoltage category 3 (IEC 60664-1).

Efficiency

Approximately 95 to 98% at nominal power level, depending on the drive size and options

Degrees of protection

IP20 (cabinet installation) / UL open: Standard enclosure. The drive must be installed in a cabinet to fulfil the requirements for shielding from contact.

IP20 / NEMA 1: Achieved with an option kit including a hood and a connection box.

Ambient conditions

Environmental limits for the drive are given below. The drive is to be used in a heated indoor controlled environment.

	Operation installed for stationary use	Storage in the protective package	Transportation in the protective package
Installation site altitude	0 to 2000 m (6600 ft) above sea level (above 1000 m [3300 ft], see section Derating on page 388)	-	-
Air temperature	-10 to +50 °C (14 to 122 °F). No frost allowed. See section Derating on page 388 .	-40 to +70 °C (-40 to +158 °F)	-40 to +70 °C (-40 to +158 °F)
Relative humidity	0 to 95%	Max. 95%	Max. 95%
No condensation allowed. Maximum allowed relative humidity is 60% in the presence of corrosive gases.			
Contamination levels (IEC 60721-3-3, IEC 60721-3-2, IEC 60721-3-1)	No conductive dust allowed.		
	According to IEC 60721-3-3, chemical gases: Class 3C2 solid particles: Class 3S2. The drive must be installed in clean air according to enclosure classification. Cooling air must be clean, free from corrosive materials and electrically conductive dust.	According to IEC 60721-3-1, chemical gases: Class 1C2 solid particles: Class 1S2	According to IEC 60721-3-2, chemical gases: Class 2C2 solid particles: Class 2S2
Sinusoidal vibration (IEC 60721-3-3)	Tested according to IEC 60721-3-3, mechanical conditions: Class 3M4 2...9 Hz, 3.0 mm (0.12 in) 9...200 Hz, 10 m/s ² (33 ft/s ²)	-	-
Shock (IEC 60068-2-27, ISTA 1A)	Not allowed during operation.	According to ISTA 1A. Max. 100 m/s ² (330 ft/s ²), 11 ms.	According to ISTA 1A. Max. 100 m/s ² (330 ft/s ²), 11 ms.
Free fall	Not allowed	76 cm (30 in)	76 cm (30 in)

Materials

Drive enclosure

- PC/ABS 2 mm, PC+10%GF 2.5...3 mm and PA66+25%GF 1.5 mm, all in color NCS 1502-Y (RAL 9002 / PMS 420 C)
- hot-dip zinc coated steel sheet 1.5 mm, thickness of coating 20 micrometers
- extruded aluminium AISi.

Package

Corrugated cardboard.

Disposal

The drive contains raw materials that should be recycled to preserve energy and natural resources. The package materials are environmentally compatible and recyclable. All metal parts can be recycled. The plastic parts can either be recycled or burned under controlled circumstances, according to local regulations. Most recyclable parts are marked with recycling marks.

If recycling is not feasible, all parts excluding electrolytic capacitors and printed circuit boards can be landfilled. The DC capacitors contain electrolyte, which is classified as hazardous waste within the EU. They must be removed and handled according to local regulations.

For further information on environmental aspects and more detailed recycling instructions, please contact your local ABB distributor.

Applicable standards

The drive complies with the following standards:

- **IEC/EN 61800-5-1: 2003** Electrical, thermal and functional safety requirements for adjustable frequency a.c. power drives
- **IEC/EN 60204-1: 2006** Safety of machinery. Electrical equipment of machines. Part 1: General requirements. *Provisions for compliance:* The final assembler of the machine is responsible for installing
 - an emergency-stop device
 - a supply disconnecting device.
- **IEC/EN 61800-3: 2004** Adjustable speed electrical power drive systems. Part 3: EMC requirements and specific test methods
- **UL 508C** UL Standard for Safety, Power Conversion Equipment, third edition

CE marking

The CE mark is attached to the drive to verify that the drive follows the provisions of the European Low Voltage and EMC Directives (Directive 73/23/EEC, as amended by 93/68/EEC, and Directive 2004/108/EC).

■ Compliance with the European EMC Directive

The EMC Directive defines the requirements for immunity and emissions of electrical equipment used within the European Union. The EMC product standard (EN 61800-3:2004) covers requirements stated for drives. See section [Compliance with EN 61800-3:2004](#) on page 401.

Compliance with EN 61800-3:2004

■ Definitions

EMC stands for **E**lectromagnetic **C**ompatibility. It is the ability of electrical/electronic equipment to operate without problems within an electromagnetic environment. Likewise, the equipment must not disturb or interfere with any other product or system within its locality.

First environment includes establishments connected to a low-voltage network which supplies buildings used for domestic purposes.

Second environment includes establishments connected to a network not directly supplying domestic premises.

Drive of category C2: drive of rated voltage less than 1000 V and intended to be installed and commissioned only by a professional when used in the first environment.

Note: A professional is a person or organization having necessary skills in installing and/or commissioning power drive systems, including their EMC aspects.

Category C2 has the same EMC emission limits as the earlier class first environment restricted distribution. EMC standard IEC/EN 61800-3 does not any more restrict the distribution of the drive, but the using, installation and commissioning are defined.

Drive of category C3: drive of rated voltage less than 1000 V, intended for use in the second environment and not intended for use in the first environment.

Category C3 has the same EMC emission limits as the earlier class second environment unrestricted distribution.

■ **Category C2**

The emission limits are complied with the following provisions:

1. The optional EMC filter is selected according to the ABB documentation and installed as specified in the EMC filter manual.
2. The motor and control cables are selected as specified in this manual.
3. The drive is installed according to the instructions given in this manual.
4. Motor cable length maximum 30 m (100 ft) with 4 kHz switching frequency.

Note: In a domestic environment, this product may cause radio interference, in which case supplementary mitigation measures may be required.

■ **Category C3**

The immunity performance of the drive complies with the demands of IEC/EN 61800-3, second environment (see page [401](#) for IEC/EN 61800-3 definitions).

The emission limits are complied with the following provisions:

1. The internal EMC filter is connected (the metal screw at EMC is in place) or the optional EMC filter is installed.
2. The motor and control cables are selected as specified in this manual.
3. The drive is installed according to the instructions given in this manual.
4. With the internal EMC filter: motor cable length 30 m (100 ft) with 4 kHz switching frequency.

Notes:

- A drive of category C3 is not intended to be used on a low-voltage public network which supplies domestic premises. Radio frequency interference is expected if the drive is used on such a network.
 - It is not allowed to install a drive with the internal EMC filter connected on IT (ungrounded) systems. The supply network becomes connected to ground potential through the EMC filter capacitors which may cause danger or damage the drive.
 - It is not allowed to install a drive with the internal EMC filter connected on a corner grounded TN system as this would damage the drive.
-

UL marking

See the type designation label for the valid markings of your drive.

The UL mark is attached to the drive to verify that it meets UL requirements.

■ UL checklist

Input power connection – See section [Electric power network specification](#) on page 397.

Disconnecting device (disconnecting means) – See [Selecting the supply disconnecting device \(disconnecting means\)](#) on page 36.

Ambient conditions – The drives are to be used in a heated indoor controlled environment. See section [Ambient conditions](#) on page 399 for specific limits.

Input cable fuses – For installation in the United States, branch circuit protection must be provided in accordance with the National Electrical Code (NEC) and any applicable local codes. To fulfill this requirement, use the UL classified fuses given in section [Size of copper conductor in cabling](#) on page 393.

For installation in Canada, branch circuit protection must be provided in accordance with Canadian Electrical Code and any applicable provincial codes. To fulfill this requirement, use the UL classified fuses given in section [Size of copper conductor in cabling](#) on page 393.

Power cable selection – See section [Selecting the power cables](#) on page 37.

Power cable connections – For the connection diagram and tightening torques, see section [Connecting the power cables](#) on page 50.

Overload protection – The drive provides overload protection in accordance with the National Electrical Code (US).

C-Tick marking

See the type designation label for the valid markings of your drive.

C-Tick marking is required in Australia and New Zealand. A C-Tick mark is attached to the drive to verify compliance with the relevant standard (IEC 61800-3:2004 – Adjustable speed electrical power drive systems – Part 3: EMC product standard including specific test methods), mandated by the Trans-Tasman Electromagnetic Compatibility Scheme.

The Trans-Tasman Electromagnetic Compatibility Scheme (EMCS) was introduced by the Australian Communication Authority (ACA) and the Radio Spectrum Management Group (RSM) of the New Zealand Ministry of Economic Development (NZMED) in November 2001. The aim of the scheme is to protect the radio frequency spectrum by introducing technical limits for emission from electrical/electronic products.

For fulfilling the requirements of the standard, see section [Compliance with EN 61800-3:2004](#) on page [401](#).

RoHS marking

The RoHS mark is attached to the drive to verify that drive follows the provisions of the European RoHS Directive. RoHS = the restriction of the use of certain hazardous substances in electrical and electronic equipment.



Dimension drawings

Contents of this chapter

This chapter contains the dimension drawings of the ACS320. The dimensions are given in millimeters and [inches].

Frame sizes R0 and R1, IP20 (cabinet installation) / UL open

R1 and R0 are identical except for the fan at the top of R1.

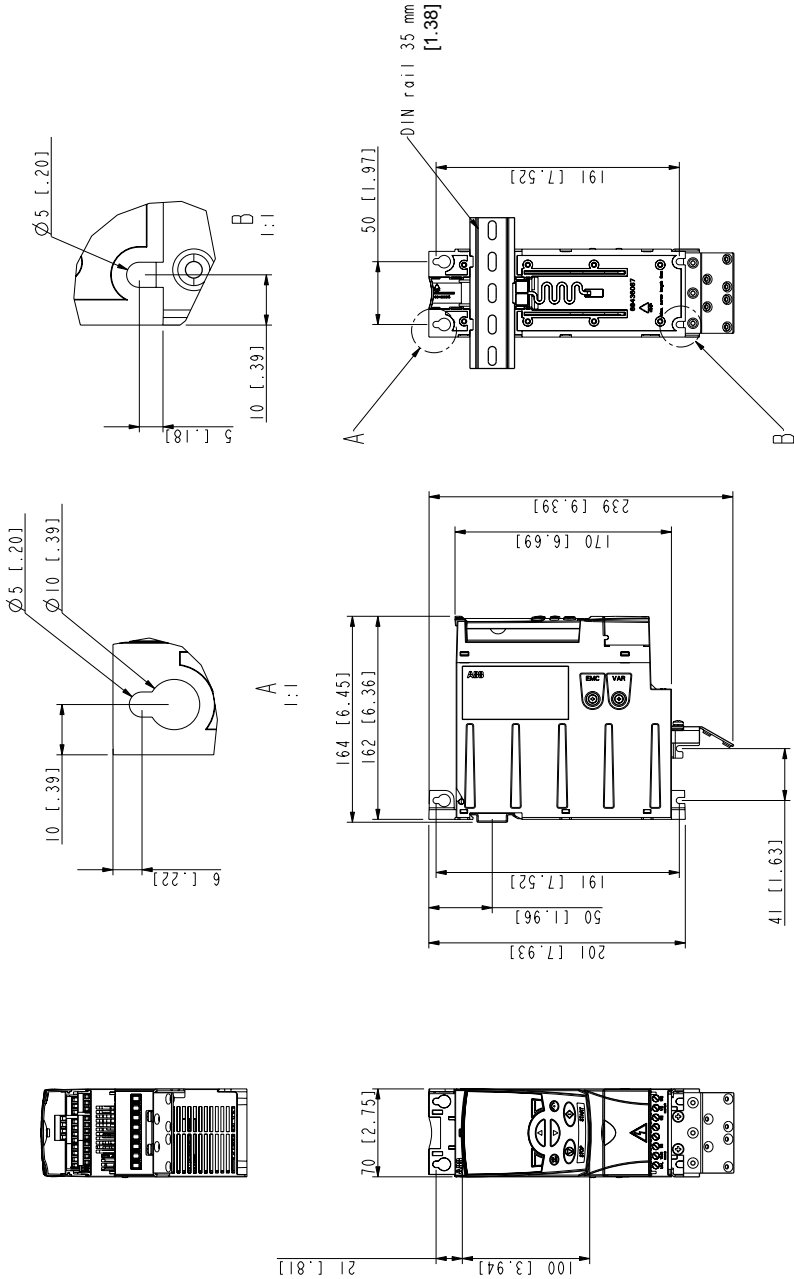

Frame sizes R0 and R1, IP20 (cabinet installation) / UL open

3AUA0000050967-A

Frame sizes R0 and R1, IP20 / NEMA 1

R1 and R0 are identical except for the fan at the top of R1.

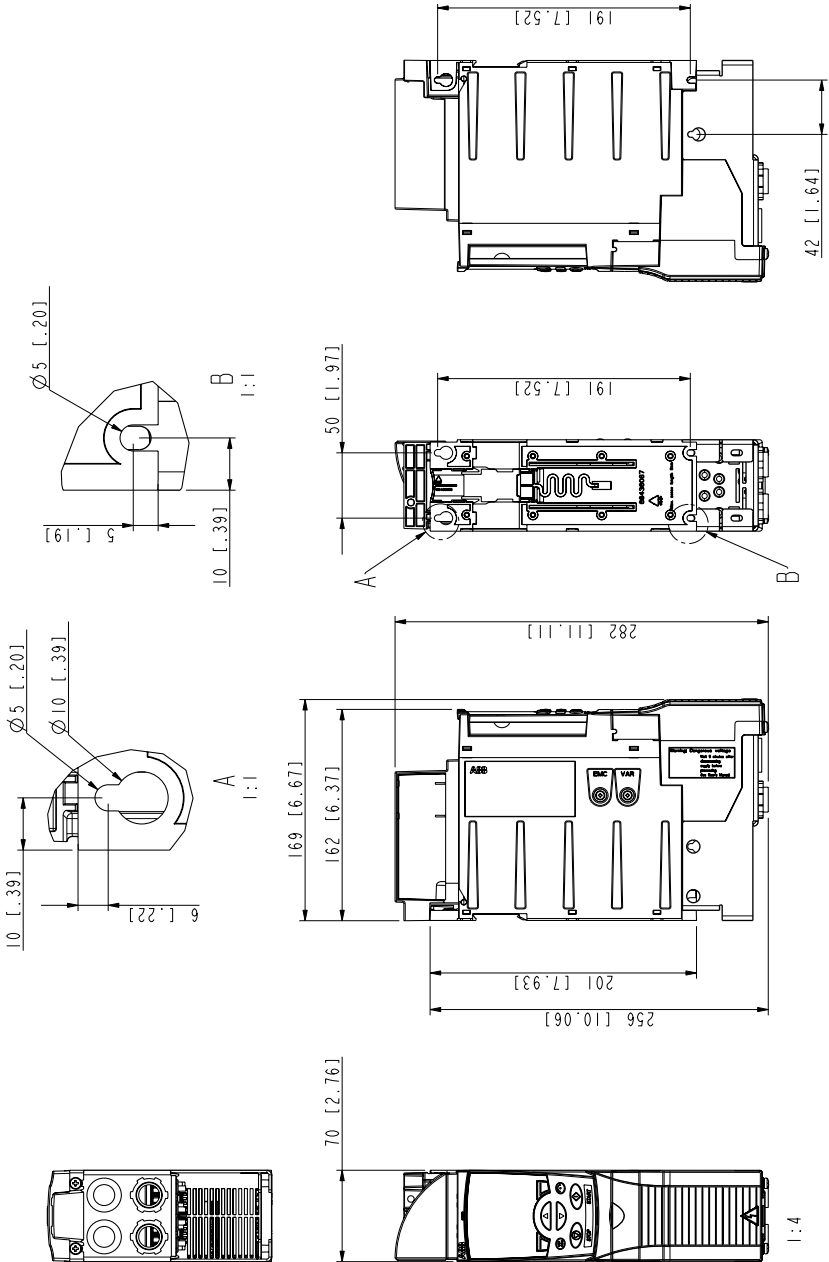

Frame sizes R0 and R1, IP20 / NEMA 1

Frame size R2, IP20 (cabinet installation) / UL open

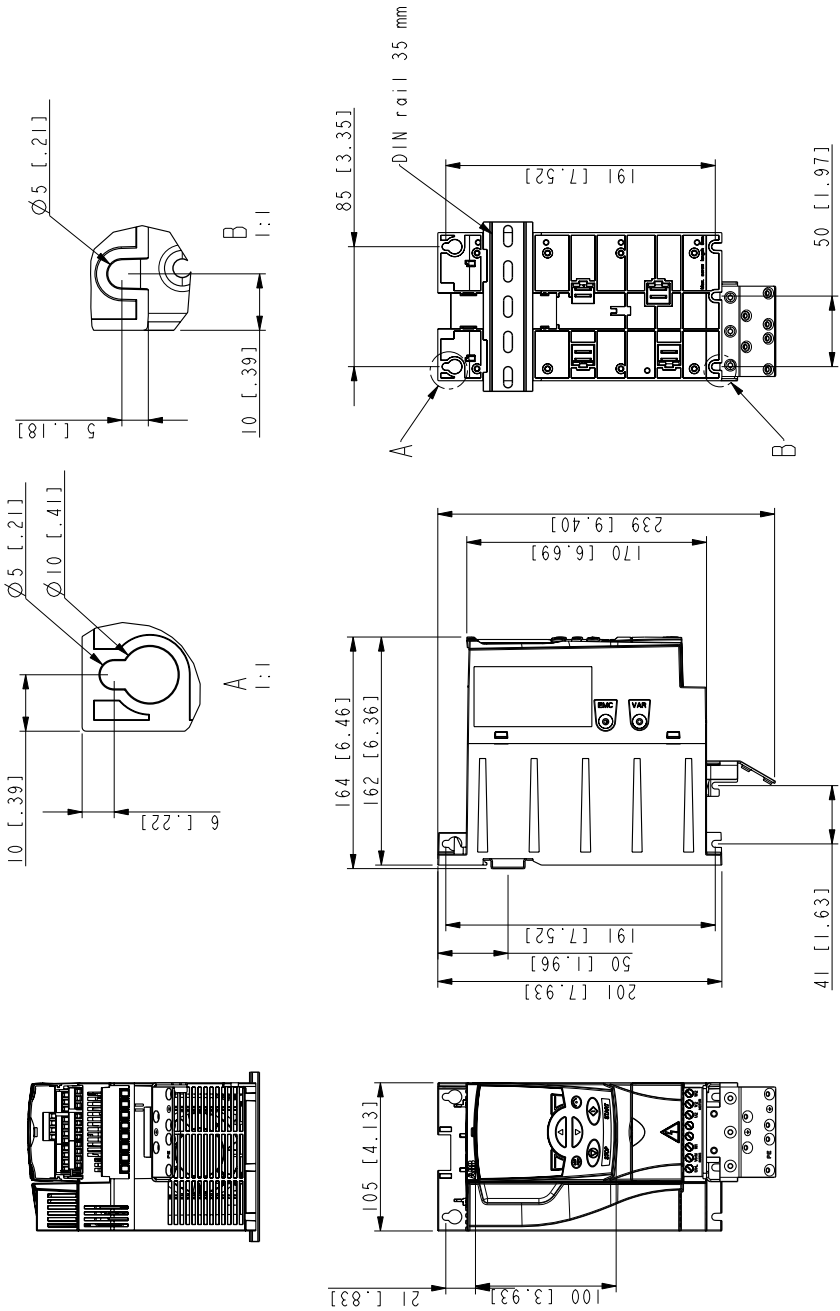

3AUA0000051090-A
Frame size R2, IP20 (cabinet installation) / UL open

Frame size R2, NEMA 1

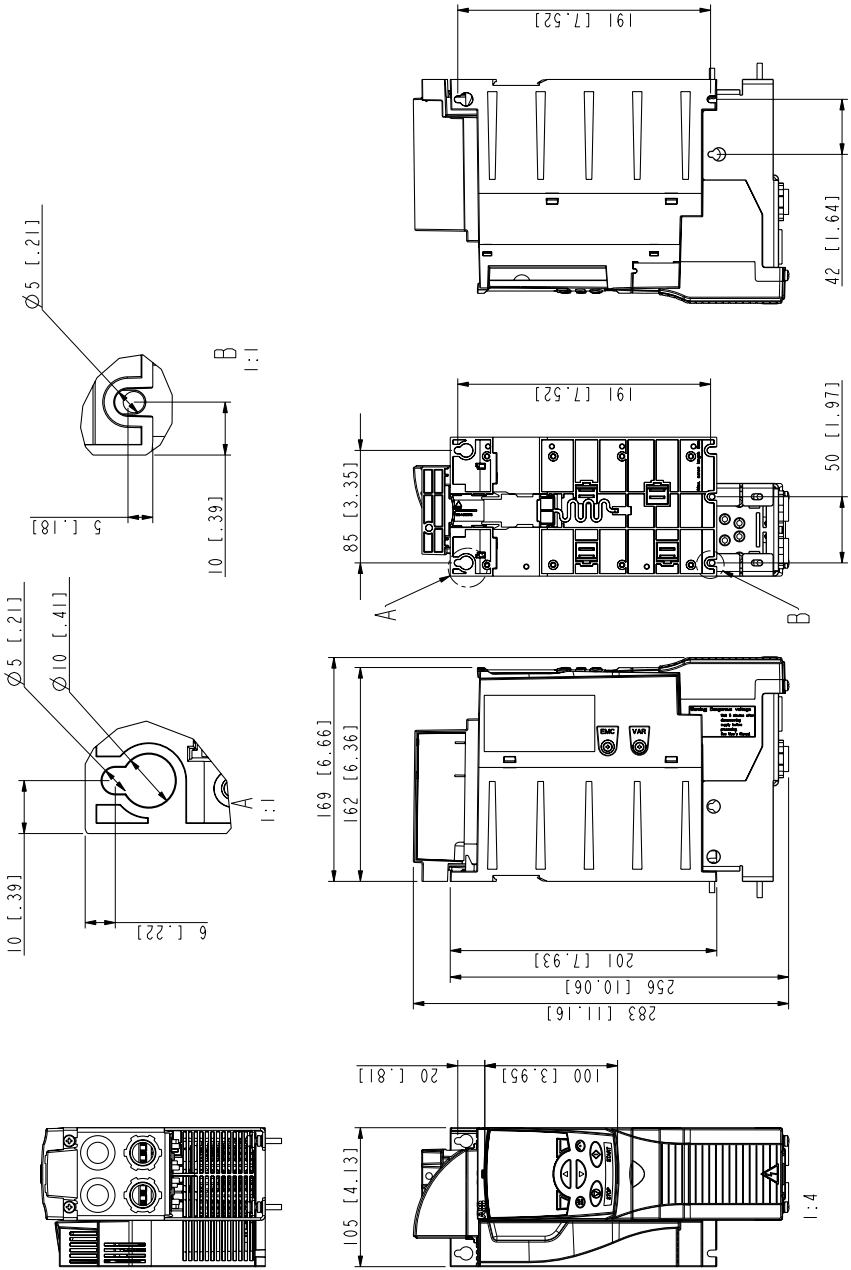

Frame size R2, IP20 / NEMA 1

3AJUA0000051097-A

Frame size R3, IP20 (cabinet installation) / UL open

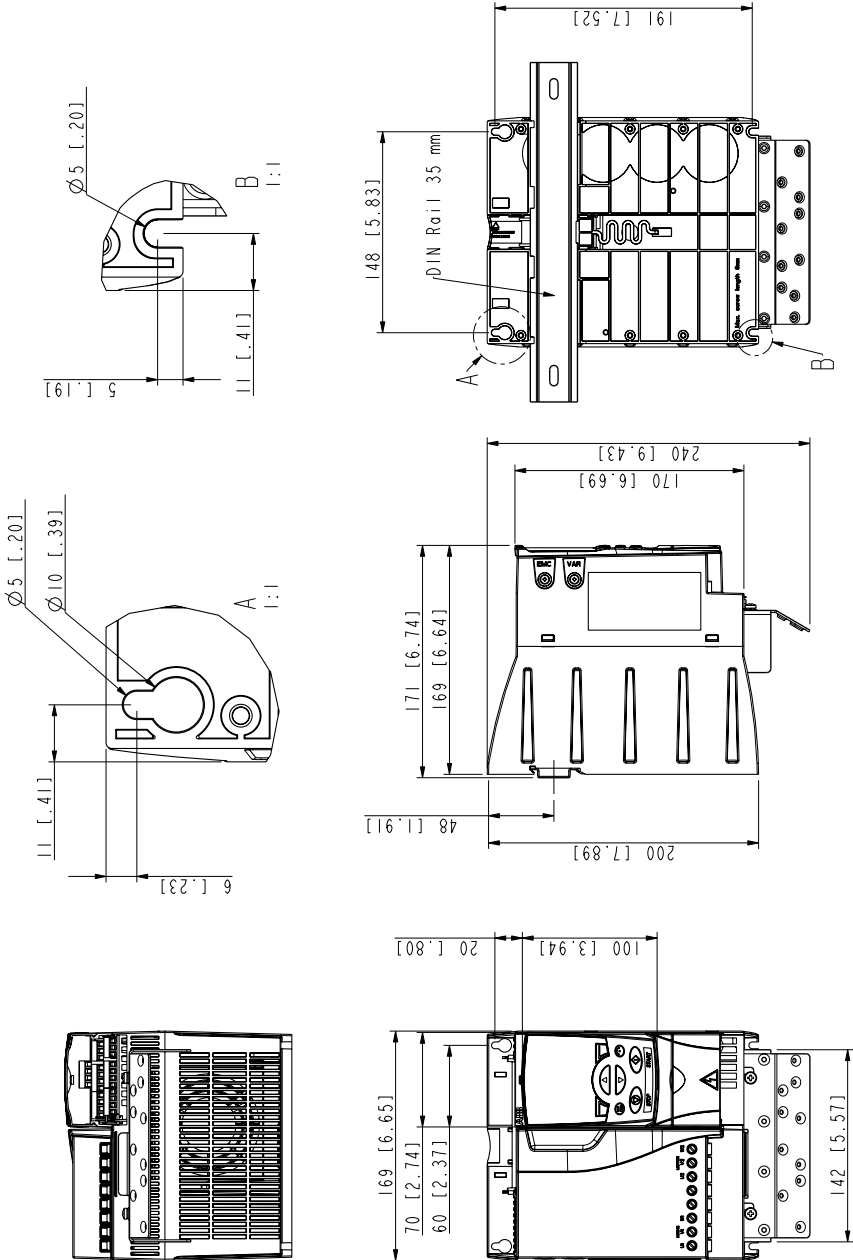

Frame size R3, IP20 (cabinet installation) / UL open

3AUA0000051109-A

Frame size R3, NEMA 1

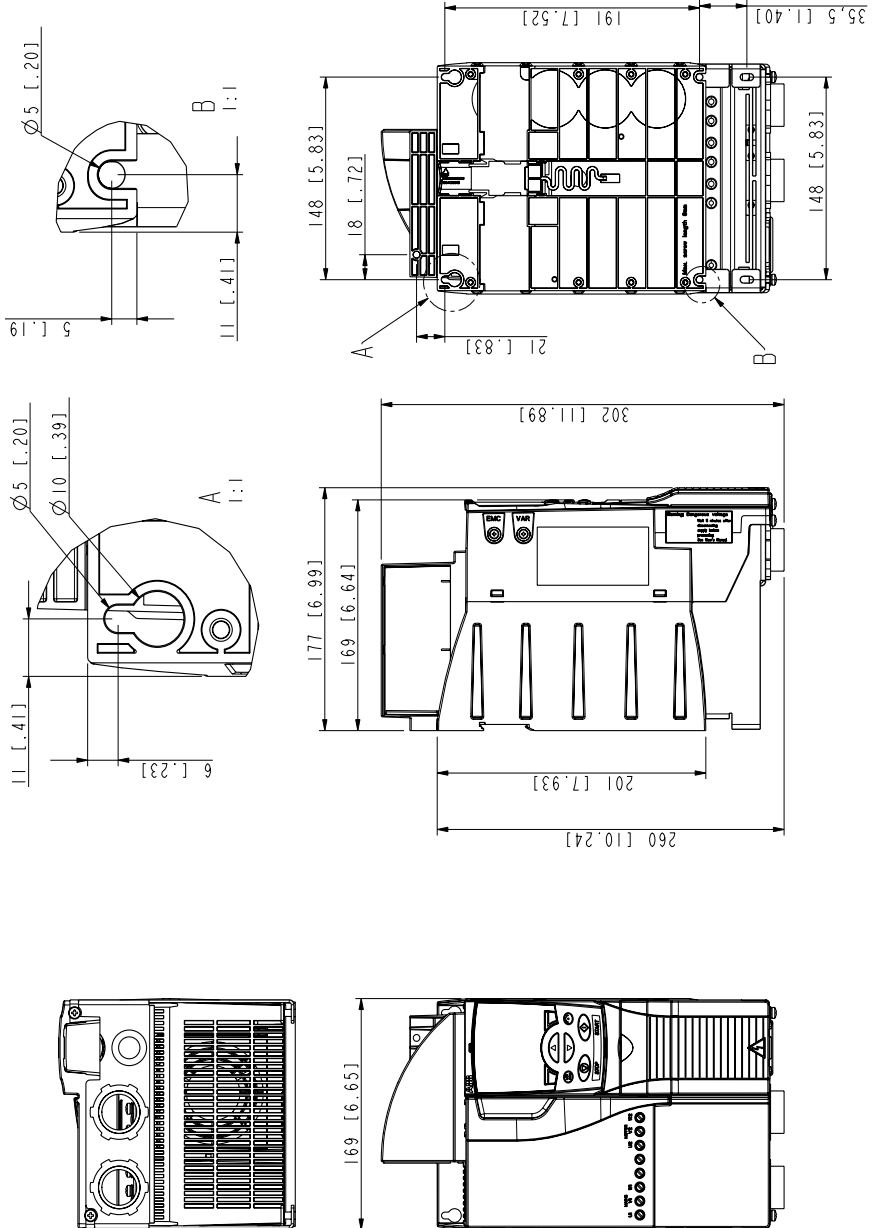

Frame size R3, IP20 / NEMA 1

Frame size R4, IP20 (cabinet installation) / UL open

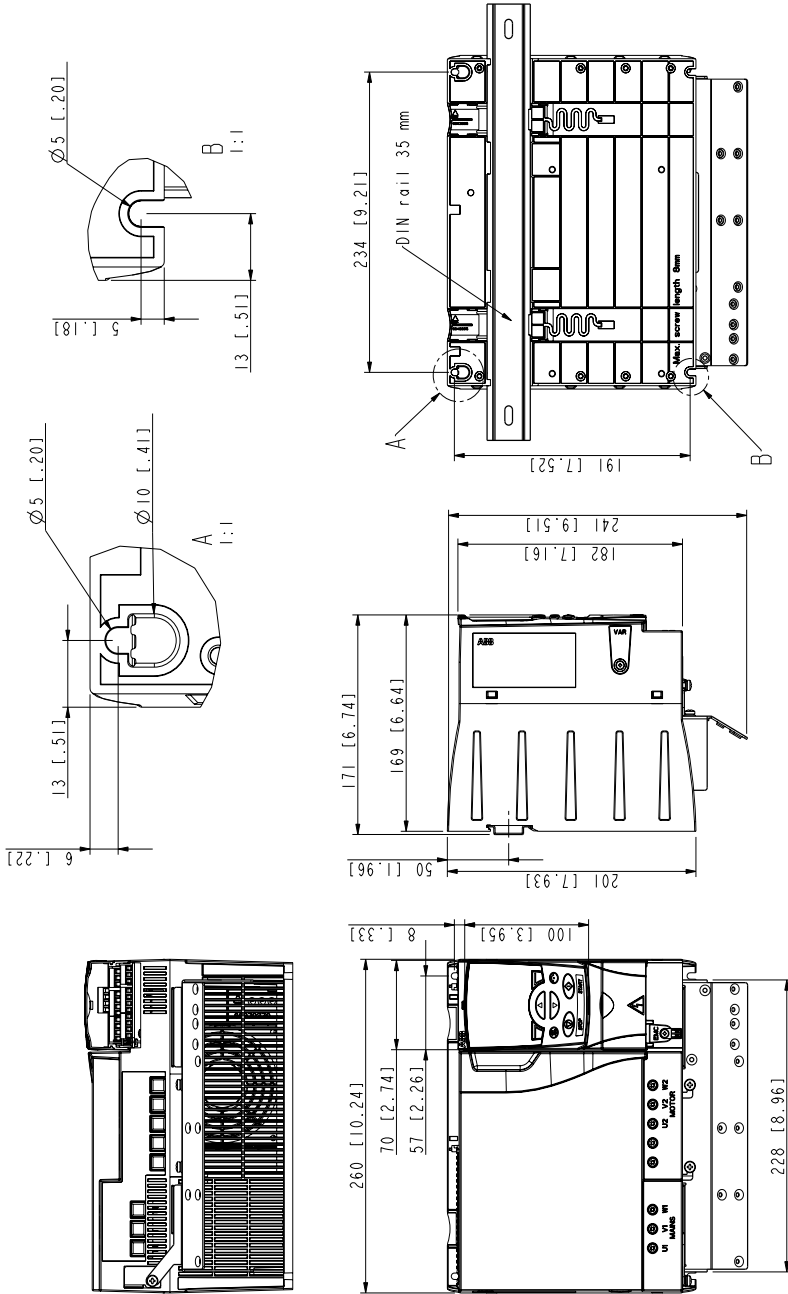

Frame size R4, IP20 (cabinet installation) / UL open

3AUA0000051130-A

Frame size R4, NEMA 1

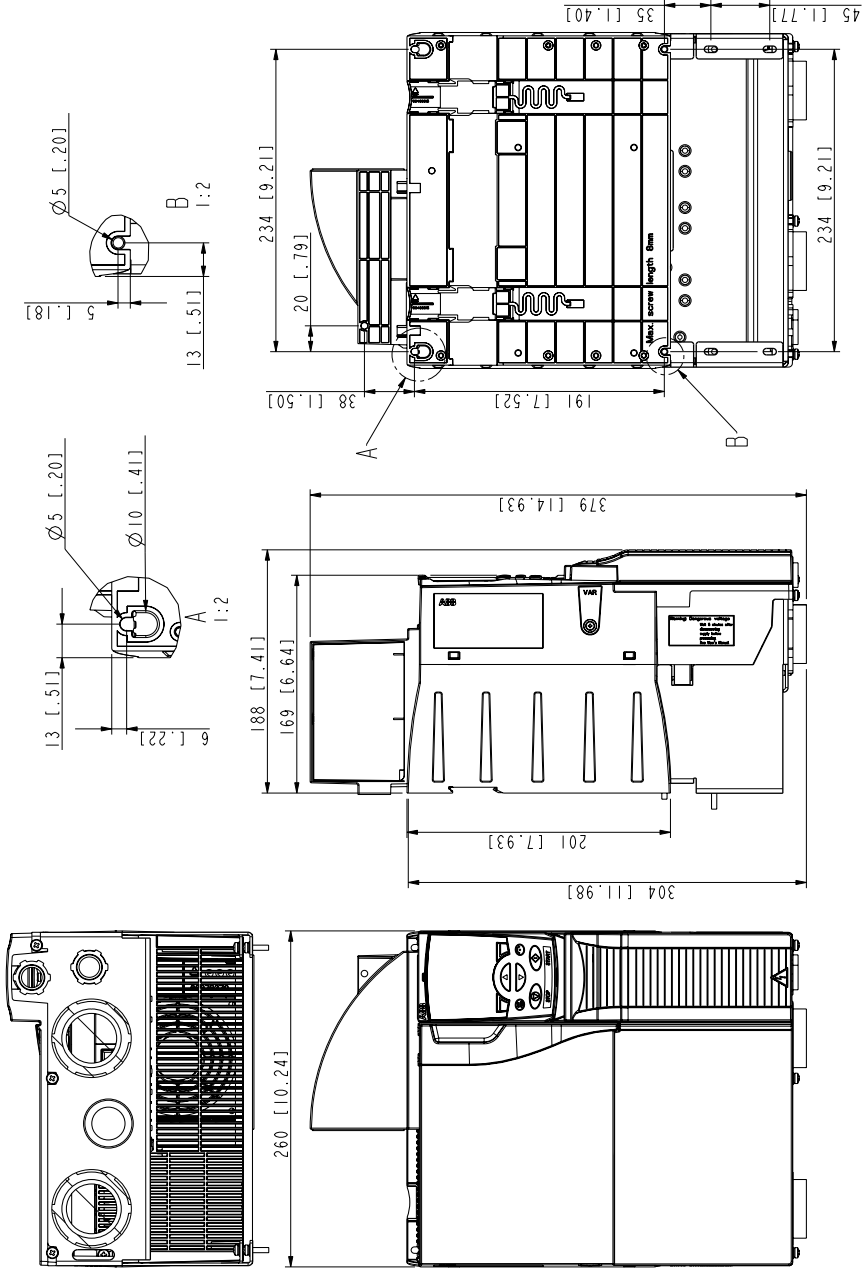

Frame size R4, IP20 / NEMA 1

3AJUA0000051133-A



Index

Numerics

0xxxx register

 EFB function codes 341

 EFB mapping 340

1xxxx register

 EFB function codes 342

 EFB mapping 341

3xxxx register

 EFB function codes 343

 EFB mapping 342

4xxxx register

 EFB function codes 346

 EFB mapping 343

A

acceleration

 /deceleration, parameter group 197

 at aux. stop (PFA), parameter 279

 ramp select, parameter 197

 ramp shape, parameter 198

 ramp time (PFA), parameter 279

 ramp zero select, parameter 199

 time, parameter 197

activate (external PID), parameter 246

actual input (PID), parameters 237

actual max. (PID), parameters 238

actual min. (PID), parameters 238

actual signals, parameter group 157

actual values

 scaling, EFB comm 300

 scaling, FLN fieldbus 317

- air flow 380
- alarm
 - codes 367
 - enable display, parameter 186
 - listing 367
- altitude
 - environment limit 399
 - shipping limit 399
- altitude derating 388
- analog cable
 - requirements 41
- analog I/O
 - connections 52
 - specifications 52
- analog input
 - BACnet object listing 330
 - data parameter 153
 - fault limit, parameters 209
 - filter, parameters 175
 - less than min. auto. reset, parameter 211
 - less than min., fault parameter 205
 - maximum, parameters 175
 - minimum, parameters 175
 - N2 object listing 307
 - parameter group 175
 - ref. correction formula 168
- analog output
 - BACnet object listing 330
 - content max., parameters 181
 - content min., parameters 180
 - current max., parameters 181
 - current min., parameters 181
 - data content, parameters 180
 - data parameter 153
 - filter, parameters 181

- N2 object listing 308
 - parameter group 132, 180
- application block output, data parameter 153
- application macro, parameter 150, 152, 157, 161, 164, 165
- applications
 - see macros
- autochange
 - interval, parameter 270
 - level, parameter 271
 - overview 271
 - starting order counter 272
- automatic reset
 - see reset, automatic
- auxiliary motor
 - see motor, auxiliary
- B
- backing up parameters (Assistant panel) 72
- backup
 - drive parameters 72
- BACnet
 - data link layer 334
 - mac id 334
 - max info frame property 334
 - MS/TP token counter 335
 - object, analog inputs 330
 - object, analog outputs 330
 - object, analog values 331
 - object, binary inputs 327
 - object, binary outputs 327
 - object, binary values 328
 - object, definitions 337
 - pics, statement 335
 - pics, summary 337
 - services supported 334

- support, matrix 337
- battery, assistant control panel 382
 - maintenance procedure 382
- baud rate (RS232), parameter 257
- binary input
 - BACnet object listing 327
 - N2 object listing 308
- binary output
 - BACnet object listing 327
 - N2 object listing 309
- branch circuit protection 36, 403
- break point frequency, fault parameter 208
- buffer overruns (count), parameter 257
- C
- cable requirements
 - grounding 41, 52, 56
 - input power 37
 - motor 39
- capacitor
 - maintenance interval 379
 - reforming 382
- CE marking 401
- CISPR11 class A
 - radiation limits 402
- CISPR11 class B
 - radiation limits 402
- clock 77
- comm
 - fault function, parameter 209
 - fault time, parameter 209
 - protocol select, parameter 280
 - relay output word, data parameter 154
 - values, data parameter 154
- comm (EFB)

- actual value scaling 300
- actual values 299
- also see RS232 257
- analog output control, activate 298
- baud rate, parameter 258
- comm fault response 209, 298
- config file, fault code 372
- configuration 290
- configure for loss of communication 302
- control interface 25, 287
- control profile, parameter 259
- control word 347
- CRC errors (count), parameter 259
- diagnostics 301
- drive control of functions, activate 294
- exception codes 346
- fault code 28 302
- fault code 31 303
- fault code 32 303
- fault code 33 303
- fault codes 373
- fault tracing parameters 301
- fault, duplicate device address 377
- fault, duplicate stations 302
- fault, intermittent off-line 303
- fault, no master station on line 302, 377
- fault, swapped wires 302, 377
- feedback from drive 299
- feedback from drive, mailbox 299
- input ref. sel., activate 295
- installation 57, 288
- mailbox, param. read/write 299
- modbus actual values 346
- normal operation 301
- ok messages (count), parameter 259

- overview 285
- parameter group 257
- parameters 259
- parity, parameter 258
- PID control setpoint source, activate 298
- planning 287
- profiles 339
- protocol id, parameter 258
- protocol, parameter group 258, 260
- reference scaling, ABB drives profile 357
- relay output control, activate 297
- set-up 290
- start/stop control, activate 294
- state diagram 356
- station id, parameter 258
- status word 351
- status, parameter 259
- termination 288
- UART errors (count), parameter 259, 260
- comm (FBA)
 - comm fault response 209
- config file
 - fault code 372
- connections
 - EFB comm 57, 288
- constant speed
 - see speed, constant
- construction code 27
- contamination levels
 - environment limit 399
 - shipping limit 399
- contrast, control panel 62
- control
 - connection specifications 398
 - location, data parameter 152

- control cable
 - requirements 41
- control panel
 - backup, drive parameters 72
 - cable requirements 41
 - changed parameters mode 72
 - clock set 77
 - comm error, fault parameter 206
 - contrast 62
 - display contrast 62
 - display decimal point (form), parameters 216
 - display max., parameters 217
 - display min., parameters 216
 - display process variables, parameter group 215
 - display selection, parameters 215
 - display units, parameters 216
 - features 61
 - i/o settings mode 80
 - maintenance interval, battery 379
 - maintenance procedure 382
 - modes 66
 - operating the drive 68
 - parameter editing 65
 - parameter lock, parameter 182
 - parameters mode 68
 - pass code, parameter 182
 - reference control, parameter 165
 - signal max., parameters 215
 - signal min., parameters 215, 220
 - soft keys 62
 - start-up assistant 64
 - start-up assistant mode 70
 - status information 67
- control panel (Assistant)
 - battery maintenance procedure 382

- fault logger mode 72
- parameter backup mode 72
- control word
 - comm (EFB), description 347
- cooling 380
 - fan maintenance triggers 204
- cooling fan 380
- correction source (PID), parameter 247
- cover
 - remove 56
- CRC errors (count), parameter 258
- critical speeds (avoiding)
 - high, parameters 200
 - low, parameters 200
 - parameter group 200
 - select, parameter 200
- C-Tick marking 403
- current
 - at fault, history parameter 161
 - data parameter 152
 - max. limit, parameter 193
 - measurement, fault code 372
 - rating code 27

D

- DC brake time, parameter 195
- DC bus voltage, data parameter 152
- DC current ref., parameter 195
- DC magnetizing time, parameter 195
- DC overvoltage, fault code 363, 370
- DC stabilator, parameter 203
- DC undervoltage, fault code 363, 370
- DDL file (N2) 310
- deceleration
 - at aux. start (PFA), parameter 279

- emergency time, parameter 198
- parameter group 197
- ramp select, parameter 197
- ramp shape, parameter 198
- ramp time (PFA), parameter 279
- ramp zero select, parameter 199
- time, parameter 198

default macro 85

derating

- altitude 388
- switching frequency 389
- temperature 388

derivation time (PID), parameter 232

device overtemperature, fault code 370

device type (N2) 307

diagnostics

- EFB comm 301

differences list, downloads 76

digital cable

- requirements 41

digital input

- at fault, history parameters 161
- connections 52

digital output

- connections 52
- specifications 398

direction

- control, parameter 164

display format (PID), parameter 233, 248

download

- failure 77
- handling inexact transfers 76
- parameter sets 74

drive

- control terminal 52

- device type (N2) 307
- EFB comm installation 57, 288
- fan replacement 380
- id, fault code 372
- identification 27
- rating, parameter 214
- temperature, data parameter 152
- weight 394
- drive input protection 43
- drive on time, data parameters 154
- E
- earth fault
 - fault code 371
 - parameter 209
- earthing
 - see ground
- efficiency 398
- embedded field bus
 - see comm (EFB)
- EMC
 - CE marking 401
 - C-Tick marking 403
 - motor cable requirements 37
- emergency
 - deceleration time, parameter 198
 - stop select, parameter 196
- EN 61800-3 first environment
 - restricted distribution radiation limits 402
 - unrestricted distribution radiation limits 402
- enclosure protection class code 27
- energy savings group 253
- environment
 - first, definition 401
 - second, definition 401

- error value inversion (PID), parameter 233
- exception codes, EFB modbus 346
- external commands selection, parameter 162
- external control selection, parameter 165
- external fault

 - automatic reset, parameter 211
 - parameters 206

- external reference, data parameter 152

F

- fan, drive module

 - maintenance interval 379
 - replacement procedure 380

- fault

 - codes 370
 - comm (FBA) 209
 - comm failure (EFB) 209, 298
 - current at, history parameter 161
 - digital input status at, history parameter 161
 - frequency at, history parameter 161
 - functions, parameter group 205
 - history 362
 - history, parameter group 161
 - last, history parameter 161
 - listing 370
 - previous, history parameter 161
 - reset 57, 361
 - reset select, parameter 182
 - speed at, history parameter 161
 - time of, history parameters 161
 - torque at, history parameter 161
 - voltage at, history parameter 161
 - words, data parameters 159

- fault code

 - 28 serial 1 err 302

- fault history 362
- fault logging (Assistant panel) 72
- features
 - N2 fieldbus 304
- feedback multiplier (PID), parameter 237
- feedback select (PID), parameter 236
- fieldbus
 - command words, data parameters 157
 - status words, data parameters 158
- firmware test date, parameter 214
- firmware version, parameter 214
- first environment, definition 401
- FlashDrop
 - parameter view, parameter 186
- FLN fieldbus
 - also see comm (EFB)
 - description 313
 - loop gains 318
 - point database 318
 - point descriptions 321
 - reports 313
 - supported features 313
- force trip, fault code 372
- frame errors (count), parameter 257, 259
- frame size 395
- free fall
 - stress testing 399
- free space
 - for cooling 380
- freq in & tran out 190
- frequency
 - at fault, history parameter 161
 - max. limit, parameter 193
 - min. limit, parameter 193
 - motor, resolution 397

- motor, specification 397
- switching, parameter 202

G

- gain (PID), parameter 231
- generic profile
 - actual value scaling 300
 - reference scaling 357

ground

- cable/wire requirements 41, 52, 56

H

- heat loss 380

I

- incomp swtype, fault code 373

information

- parameter group 214

input power

- branch circuit protection 36, 403
- cable/wire requirements 37
- specifications 397

input power connection 50

- terminal size 396
- torque 396

installation

- compatibility 36
- environment 399
- flow chart 22
- location 29
- tools 30

insulation

- check 48

- integration time (PID), parameter 232, 246

interlocks

- parameter 273

- internal setpoint (PID), parameter 235

IR compensation

- frequency, parameter 201

- parameters 201

- voltage, parameter 201

K

- keypad reference select, parameter 165

- kWh counter, data parameter 153

L

- language, parameter 150

- limits, parameter group 193

- load analyzer group 260

- load frequency, see user load curve

- load package version, parameter 214

- load torque, see user load curve

- local mode

 - lock, parameter 184

- low frequency (PFA), parameters 266

M

macros

- booster pump 90

- condenser 89

- cooling tower fan 88

- dual setpoint w/ PID 95

- dual setpoint w/ PID & const. speeds 96

- floating point 94

- hand control 98, 100

- HVAC default 85

- internal timer 92

- internal timer w/constant speeds 93

- listing 84

- return fan 87

- supply fan 86

- to select 83

- mailbox, EFB comm 299

- mains
 - see input power
- maintenance
 - capacitors 382
 - control panel 382
 - drive module fan 380
 - fan 380
 - intervals 379
 - triggers, parameter group 204
- mapping
 - EFB modbus 339
- materials 400
- maximum
 - frequency, parameter 193
- metasys
 - connection diagram (companion) 306
 - connection diagram (system) 306
 - integration 306
- minimum
 - frequency, parameter 193
- modbus
 - EFB addressing, convention 340
 - EFB coils 340
 - EFB discrete inputs 341
 - EFB holding registers 343
 - EFB input registers 342
 - EFB mapping details 340
 - EFB mapping summary 339
 - EFB supported features 338
- motor
 - aux. start delay (PFA), parameter 267
 - aux. stop delay (PFA), parameter 267
 - checking insulation 48
 - compatibility 36
 - connection specifications 397

- load curve break point frequency 208
- load curve max., fault parameter 207
- load curve zero speed load 207
- maintenance triggers 204
- nominal current, parameter 150
- nominal frequency, parameter 151
- nominal power, parameter 151
- nominal speed, parameter 151
- nominal voltage, parameter 150
- number of aux., parameter 267, 268
- phase, fault code 373
- stall, fault code 371
- temperature alarm limit, parameter 220
- temperature fault limit, parameter 220
- temperature measure, parameter group 219
- temperature sensor selection, parameter 220
- temperature sensor type, parameter 219
- temperature, data parameter 154
- thermal protection, fault parameter 206
- thermal time, fault parameter 207
- motor cable
 - checking insulation 48
 - max. length 397
 - requirements 39
 - requirements, EMC 37
- motor connection
 - terminal size 396
 - torque 396
- motor control
 - IR compensation, parameters 201
 - parameter group 201
- motor temperature
 - measure, parameter group 132
 - overtemperature, fault code 371
- motor, auxiliary

- actual signals and parameters 263
- aux start order, parameter 280
- MWh counter, data parameter 154
- N
- N2 fieldbus
 - also see comm (EFB)
 - description 304
 - node limit 307
 - supported features 304
- NCU
 - see network control unit
- NEMA 1
 - see UL type 1
- NEMA 12
 - see UL type 12
- network control unit
 - description 304
 - N2 DDL file 310
- noise
 - random sw. freq. parameter 203
- NPN 53
- O
- object
 - virtual, description 304
- offset (PID), parameter 246
- ok messages (count), parameter 257
- operating data, parameter group 152
- options, parameter group 280
- output frequency, data parameter 152
- output voltage, data parameter 152
- output wiring
 - fault code 373
- overcurrent
 - automatic reset, parameter 211

- fault code 370
- overspeed, fault code 372
- P
- panel display variables, parameter group 215
- panel loss, fault code 371
- parameter
 - analog input scale, fault code 375
 - analog output scale, fault code 375
 - change lock 182
 - external relay output, fault code 375
 - fieldbus, fault code 375
 - hz rpm, fault code 374
 - PCU 1 (power control unit), fault code 376
 - PCU 2 (power control unit), fault code 375
 - PFC mode, fault code 188
 - PFC ref. neg., fault code 375
 - restore (Assistant panel) 72
 - save changes, parameter 184
- parameter view, parameter 186
- parameters
 - editing 65
 - view changes 72
- parity (RS232), parameter 257
- parity errors (count), parameter 257
- PE earth
 - earth fault, parameter 209
- PE earth connection
 - terminal size 396
 - torque 396
- PFA
 - acceleration time, parameter 279
 - aux start order, parameter 280
 - aux. motor start delay, parameter 267
 - aux. motor stop delay, parameter 267

- control, parameter group 263
- deceleration time, parameter 279
- enable, parameter 278
- low frequency, parameters 266
- number of aux. motors, parameter 267, 268
- reference step, parameters 264
- start delay, parameter 277
- start frequency, parameters 265

PFC (pump fan control)
see PFA (pump fan alternation)

PID

- 0% (actual signal), parameter 233
- 100% (actual signal), parameter 233
- actual input select, parameters 237
- actual value max., parameters 238
- actual value min., parameters 238
- adjustment procedure 231
- comm value 1, data parameter 154
- comm value 2, data parameter 155
- correction source, parameter 247
- decimal point (actual signal), parameter 233, 248
- derivation filter, parameter 232
- derivation time, parameter 232
- error feedback inversion, parameter 233
- external / trimming, parameter group 245, 248, 253
- external source activate, parameter 246
- feedback multiplier, parameter 237
- feedback select, parameter 236
- feedback, data parameter 153
- gain, parameter 231
- integration time, parameter 232, 246
- internal setpoint, parameter 235
- offset, parameter 246
- output, data parameter 153
- parameter set select, parameter 242

- process sets, parameter groups 126, 228
- scaling (0%...100%), parameters 233
- setpoint maximum, parameter 236
- setpoint minimum, parameter 236
- setpoint select, parameter 234
- setpoint source, EFB comm activate 298
- setpoint, data parameter 153
- sleep delay, parameter 240, 241
- sleep level, parameter 240
- sleep selection, parameter 239
- trim mode, parameter 246
- trim scale, parameter 246
- units (actual signal), parameter 233
- wake-up delay, parameter 241
- wake-up deviation, parameter 241
- PID controller
 - advanced set-up 229
 - basic set-up 126, 228
- planning
 - EFB comm 287
- PNP 53
- power
 - data parameter 152
 - first applied 64
- previous faults, history parameters 161
- process PID sets, parameter groups 126, 228
- process variables, data parameter 154
- profiles
 - abb drives, overview 347
 - comm (EFB) 339
 - dcu, overview 347
- protection
 - branch circuit 36, 403
 - enclosure standard 399
 - environmental 398

- protocol
 - BACnet, technical data 327
- protocol implementation conformance statement
 - see BACnet, pics
- PT100 temperature sensor 219
- PTC temperature sensor 219
- pump cleaning group 255
- pump protection group 248
- R
- radiation limits, conducted
 - EN 61800-3 401
- ramp pair (accel/decel), parameter 197
- ratings 386
- reference
 - analog input corrections 168
 - corrections for parameter values 168
 - keypad control, parameter 165
 - maximum, parameters 169
 - minimum, parameters 169
 - select source, parameter 166
 - select, parameter group 164
- reference scaling
 - EFB, ABB drives profile 357
- reference step (PFA), parameters 264
- regulator by-pass control, parameter 276
- relative humidity
 - environment limit 399
 - shipping limit 399
- relay output
 - activation condition parameters 176
 - off-delay, parameters 179
 - on-delay, parameters 179
 - parameter group 176
- relays, specifications 398

- remove cover 56
- reports, FLN fieldbus 313
- reset, automatic
 - analog input less than min., parameter 211
 - delay time, parameter 210
 - external fault, parameter 211
 - number of trials, parameter 210
 - overcurrent, parameter 211
 - parameter group
 - trial time, parameter 210
 - undervoltage, parameter 211
- resonance (avoiding)
 - select, parameter 200
- revolution counter, data parameter 154
- RoHS marking 404
- RS232
 - baud rate, parameter 257
 - panel, parameter group 257
 - parity, parameter 257
 - station id, parameter 257
- RS232 counts
 - buffer overruns, parameter 257
 - CRC errors, parameter 258
 - frame errors, parameter 257, 259
 - ok messages, parameter 257
 - parity errors, parameter 257
- RS485 comm 288
- run enable
 - source select, parameter 181
- run time, data parameter 152
- S
- safety 15
- scaling
 - actual values, EFB comm 300

- FLN actual values 317
 - reference (EFB, ABB drives profile) 357
- s-curve ramp, parameter 198
- sensor type, parameter 219
- serial 1 error (fault code 28) 302
- serial 1 error, fault code 372
- setpoint maximum (PID), parameter 236
- setpoint minimum (PID), parameter 236
- setpoint select (PID), parameter 234
- shock
 - stress testing 399
- short circuit, fault code 370
- sleep selection (PID), parameter 239
- slip compensation ratio, parameter 202
- soft keys, control panel 62
- specifications
 - control connections 398
 - cooling 380
 - input power 397
 - mains 397
 - motor connections 397
- speed
 - at fault, history parameter 161
 - data parameter 152
- speed, constant
 - digital input selection parameter 171
 - parameter 173
 - parameter group 132, 170
- stall
 - frequency, fault parameter 208
 - function, fault parameter 208
 - region 208
 - time, fault parameter 208, 209
- standards
 - CE marking 401

- C-Tick marking 403
- EN 61800-3 401
- ICE/EN 60204-1 400
- IEC/EN 61800-3 400
- IEC/EN 61800-5-1 400
- UL 508C 400
- UL marking 403
- start
 - aux. motor (PFA), parameters 265
 - aux. motor delay 267
 - control, EFB comm 294
 - DC magnetizing time, parameter 195
 - delay (PFA), parameter 277
 - frequency (PFA), parameters 265
 - function, parameter 194
 - inhibit, parameter 195
 - parameter group 194
 - torque boost current, parameter 196
- start delay, parameter 196, 197
- start mode
 - automatic 194
 - automatic torque boost 194
 - DC magnetizing 194
 - flying start 194
- start/stop, parameter group 194
- start/stop/dir, parameter group 162
- starting order counter 272
- start-up
 - macros 62
 - tuning 62
- start-up assistant 64
- start-up data, parameter group 150
- state diagram
 - ABB drives 356
 - comm (EFB) 356

- station id (RS232), parameter 257
- status word
 - comm (EFB), definition 351
- stop
 - aux. motor (PFA), parameters 266
 - aux. motor delay 267
 - DC brake time, parameter 195
 - DC current ref., parameter 195
 - emergency select, parameter 196
 - function, parameter 194
 - parameter group 194
- stop function 147
 - emergency 196
 - motor 194
- supervision
 - parameter group 212
 - parameter low limit, parameters 213
 - parameter selection, parameters 212
- supply phase, fault code 372
- switching frequency control, parameter 202
- switching frequency derating 389
- switching frequency, parameter 202
- system controls, parameter group 181

T

- temperature derating 388
- termination 288
- test date, parameter 214
- thermal fail, fault code 372
- timer functions
 - parameter group 132
- timers
 - boost 224
 - enable 222
 - parameter group 220

- source 225
- start/stop time 222, 227, 257, 258, 264
- tools 30
- torque
 - at fault, history parameter 161
 - boost current, parameter 196
 - data parameter 152
- trim mode (PID), parameter 246
- trim scale (PID), parameter 246
- U
- U/f ratio, parameter 201
- UL type 1
 - code 27
 - description 398
- UL type 12
 - code 27
 - description 398
- undervoltage
 - automatic reset, parameter 211
 - control enable, parameter 193
- units (PID), parameter 233
- user load curve
 - frequency, parameters 227, 228
 - function, parameter 227
 - mode, parameter 226
 - time, parameter 227
 - torque, parameters 227, 228
- user parameter set
 - change control, parameter 183
- V
- vibration
 - stress testing 399
- virtual object, N2 304
- VND 307

voltage

at fault, history parameter 161

rating code 27

voltage/frequency ratio, parameter 201

W

wake-up delay (PID), parameter 241

wake-up deviation (PID), parameter 241

warning

automatic start up 18

dangerous voltages 16

listing 15

qualified installer 16

weight 394

wiring

fault, parameter 210

installation 42

requirements 35

Z

zero speed load, fault parameter 207



Further information

Product and service inquiries

Address any inquiries about the product to your local ABB representative, quoting the type designation and serial number of the unit in question. A listing of ABB sales, support and service contacts can be found by navigating to abb.com/searchchannels.

Product training

For information on ABB product training, navigate to new.abb.com/service/training.

Providing feedback on ABB Drives manuals

Your comments on our manuals are welcome. Navigate to new.abb.com/drives/manuals-feedback-form.

Document library on the Internet

You can find manuals and other product documents in PDF format on the Internet at abb.com/drives/documents.



abb.com/drives
abb.com/drivespartners

